

### 3 OPERATION

The 3632T / HTT 13 Telescoping Boom Lift is a Summit Series™ trailer-mounted aerial work platform, designed and manufactured to position personnel with their tools and equipment at overhead work locations. The platform load capacity is rated at 500 pounds (227 kilograms). During all aerial work platform operations, four extended outriggers support the unit.

The aerial work platform is battery powered and operated with electronic pushbutton controls, a hydraulic power unit, a hydraulic gear motor and hydraulic cylinders. The hydraulic power unit includes a reservoir, pump and control valves. Hydraulic cylinders elevate and extend the telescoping boom and maintain the platform at level during operation. The hydraulic motor and mating worm gear allow the telescoping boom to rotate 700° Non-Continuous around a vertical axis.

The hydraulic power unit uses a 24-Volt DC motor to drive the hydraulic pump. The DC motor is powered by four 6-Volt DC, 245 amp-hour deep charge batteries connected in series. An automatic onboard battery charger is provided for recharging the batteries at the end of each work period.

The ground (lower) control panel controls the power, outriggers, boom lift elevation, and rotation functions.

The platform (upper) control panel only controls boom lift elevation, and rotation.

**NOTE:** The elevation and rotation controls are operational only when the outriggers are correctly extended and the extension boom is within a programmed safe operating zone.

The ground (lower) control panel includes a lighted text window that displays the current operating status or an existing error condition.

Safety devices prevent the boom from retracting suddenly in the event of a hydraulic hose or system failure. It is strongly recommended that no one adjust or tamper with these safety devices. If service is required, contact the Customer Service Department: at 1-800-537-0540 or visit Haulotte Group online at [www.haulotte-usa.com](http://www.haulotte-usa.com).

In the event of power loss, control system failure or other malfunction, boom lowering functions may be accomplished manually.

To manually operate boom retraction, and turntable rotation functions, use the hand pump, and selected valves on the hydraulic pump unit that can be accessed inside the pump compartment.

Manual lowering of the boom and platform may also be performed by actuating the valve plunger found on the base of each boom lift cylinder. Pushing in and holding the valve "button" on the appropriate cylinder retracts that cylinder, thereby retracting that part of the boom. The boom may need to be rotated to a clear area before lowering.

## GROUND (LOWER) CONTROL PANEL

The ground (lower) control panel is used to operate outriggers and all boom functions. To access the ground (lower) control panel, open the control panel access cover found on the turntable.

The ground (lower) control panel includes the following controls and indicators. Refer to Figure 3-1.

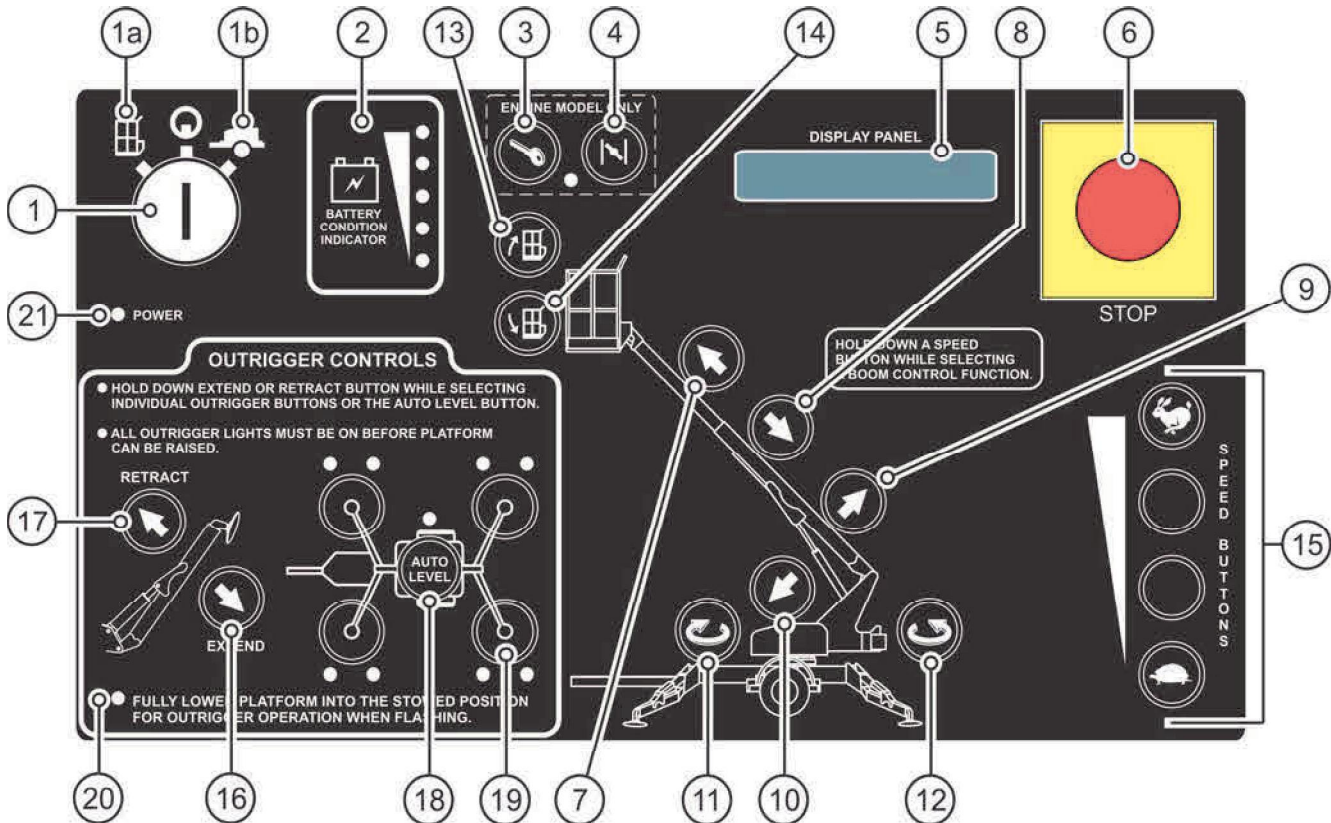

Figure 3-1. Ground Control Panel

### 1. Key Switch

Turning the **KEY SWITCH (1)** clockwise to the **GROUND (1b)** icon selects operation from the ground (lower) control panel. Turning the **KEY SWITCH (1)**, counter clockwise to the **PLATFORM (1a)** icon selects operation from the platform (upper) control panel. Turning the **KEY SWITCH (1)** to the vertical position (power "OFF") interrupts all electric and hydraulic power operations except emergency lowering. Removal of the key protects against any unauthorized person attempting to operate the aerial work platform. The **KEY** may be removed with the **KEY SWITCH (1)** in any selected position.

### 2. Battery Condition Indicator

Indicator LEDs light up to indicate the level of charge in the batteries.

- A lighted green LED indicates an adequate charge level.
- A lighted yellow LED indicates the need for charging soon.
- A lighted red LED warns that the battery charge level is low; all functional operations become non-functional until the batteries are recharged.

### 3-4. Engine Choke and Start / Glow Plug (Models with Engines Only)

Start a cold engine by pressing (pushing) in and holding the **CHOKE (4)** button then press (push) the **ENGINE START (3)** button. To start / restart a warm engine, press (push) the **ENGINE START (3)** button only.

**GLOW PLUG OPERATION** – Press (push) the **GLOW PLUG (4)** button and hold for 30-60 seconds then press (push) the **ENGINE START (3)** button.

## GROUND (LOWER) CONTROL PANEL (CONTINUED)

### 5. Display Panel

The **DISPLAY PANEL** is a lighted text window that displays the current operating status or an existing error condition when the **KEY SWITCH (1)** is positioned at either **(1a)** or **(1b)**.

### 6. Emergency Stop Button

When pushed in, the **EMERGENCY STOP (6)** button disconnects electrical power to the ground (lower) and platform (upper) control panels. The **EMERGENCY STOP** button should only be pressed (pushed) in to immediately stop all aerial work platform motion. To resume control, "pull out" the **EMERGENCY STOP (6)**.

### 7-8. Boom Extend / Retract Buttons

Pressing (pushing) in and holding a desired **SPEED (15)** button, and the **BOOM EXTEND (7)** button at the same time extends the Telescopic Boom. Pressing (pushing) in and holding a desired **SPEED (15)** button, and the **BOOM RETRACT (8)** button at the same time retracts the boom. Telescopic Boom motion continues until the buttons are released, or until the boom reaches a hard stop, or a safe travel limit.

### 9-10. Boom Raise / Down Buttons

Pressing (pushing) and holding a desired **SPEED (15)** button and the **BOOM RAISE (9)** button at the same time will raise the boom. Pressing (pushing) and holding a desired **SPEED (15)** button and the **BOOM DOWN (10)** button at the same time will lower the boom. Boom motion continues until the buttons are released or until the boom reaches a hard stop or a safe travel limit.

### 11-12. Boom Rotation Buttons

Pressing (pushing) and holding a desired **SPEED (15)** button, and the **BOOM ROTATION (11)** button at the same time enables the boom to rotate in the **CLOCKWISE** direction. Pressing (pushing) and holding a desired **SPEED (15)** button, and the **BOOM ROTATION (12)** button at the same time enables the boom to rotate in the **COUNTER CLOCKWISE** direction. The boom will rotate through 700° of Non-Continuous rotation until the buttons are released or the stop is reached.

### 13-14. Platform Tilt Buttons

Press (push) and hold any **SPEED (15)** button, and the desired **PLATFORM TILT UP (13)** or **PLATFORM TILT DOWN (14)** button at the same time to level the work platform (this levels the platform only, NOT the aerial work platform).

### 15. Speed Buttons

The **SPEED (15)** buttons are located along the lower right side of the control panel, one of the speed buttons must be pressed (pushed) in and held while selecting any boom function. There are four speeds that range from fast (**RABBIT**), to slow (**TURTLE**), available to help control the positioning of the Boom.

### 16-19. Outrigger Controls

For simultaneous automatic outrigger extension / retraction of all four (3) outriggers: select the **EXTEND (16)** or **RETRACT (17)** button and the **AUTO LEVEL (18)** button at the same time. To individually extend or retract the outriggers: select the **EXTEND (16)** or **RETRACT (17)** button and one of the four **OUTRIGGER (19)** buttons at the same time. The outrigger indicator **LED (20)** lights up when the outriggers are properly deployed and the aerial work platform weight is on the outrigger foot pads. Each of the outer outrigger LEDs indicates load is on the outrigger footpad. Each of the inner outrigger LEDs, when flashing, indicate that side is low and needs to be further raised for leveling.

### 20. Auto Level LED

When this LED is "FLASHING" it indicates that the booms are not in the "stowed" position, and the outriggers cannot be operated (non-functional). When this LED is "ON SOLID" it indicates that the booms are in the "stowed" position, and the outriggers can be operated (functional).

## PLATFORM (UPPER) CONTROL PANEL

The platform (upper) control panel is used to control all boom functions. The platform (upper) control panel is activated by turning the **KEY SWITCH (1)** on the ground (lower) control panel, clockwise to the **PLATFORM (1b)** icon. Enter the work platform using a three (3) point contact (both hands and one foot).

The platform (upper) control panel includes the following controls and indicators. Refer to Figure 3-2.

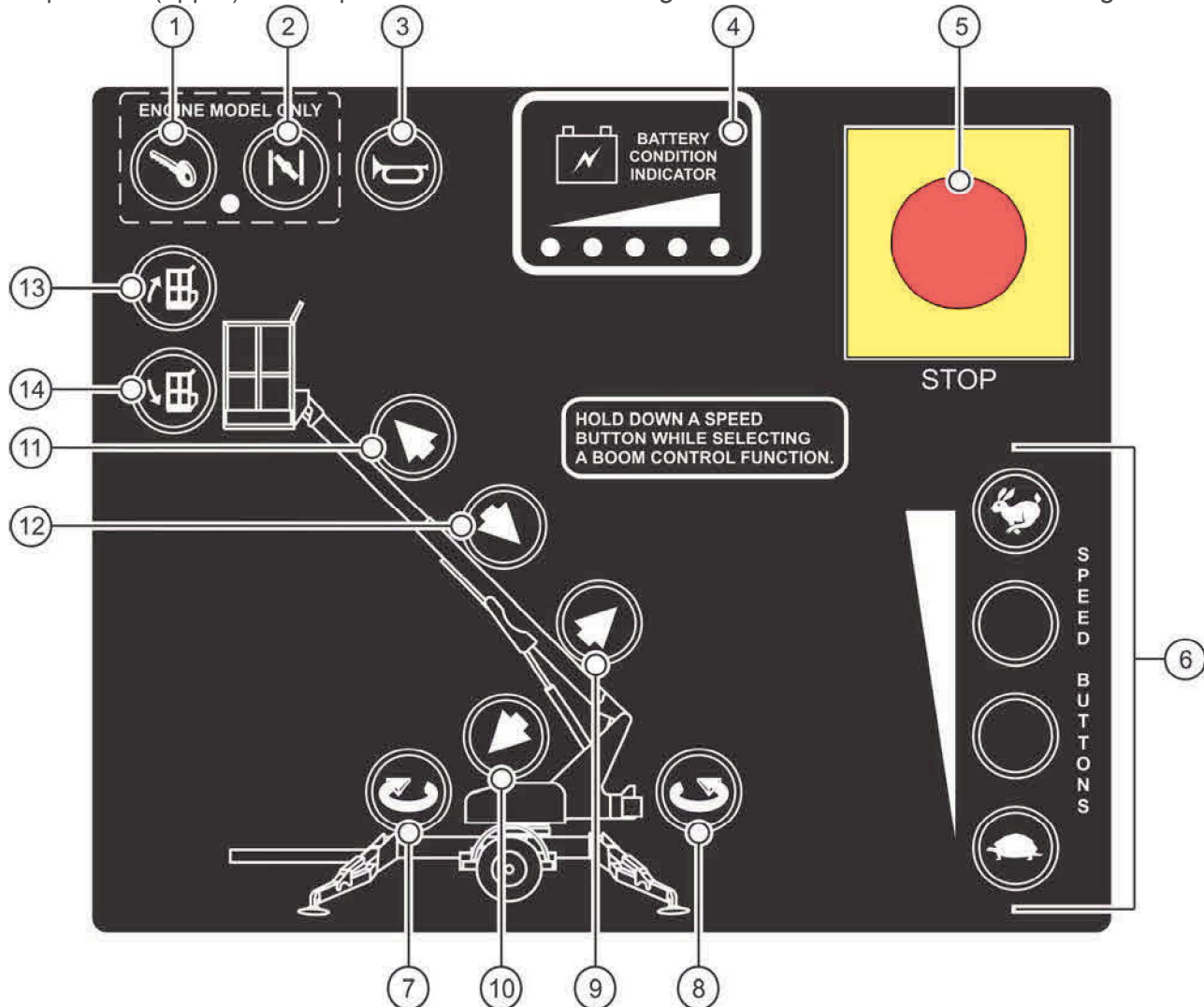

Figure 3-2. Platform Control Panel

### 1-2. Engine Choke and Start / Glow Plug (Models with Engines Only)

Start a cold engine by pressing (pushing) and holding the **CHOKE (2)** button, and pressing (pushing) the **ENGINE START (1)** button to start the Engine. To start / restart a warm Engine, press (push) the **START (1)** button only.

**GLOW PLUG OPERATION** – Press (push) and hold the **GLOW PLUG (2)** button for 30-60 seconds then press (push) the **ENGINE START (1)** button.

### 3. Horn Button

Pressing (pushing) the **HORN (3)** button will sound the **HORN**. Use the **HORN (3)** button to warn personnel in the area of a falling object hazard, impending boom motions, or the need for assistance.

## PLATFORM (UPPER) CONTROL PANEL TELESCOPIC (CONTINUED)

### 4. Battery Condition Indicator

Indicator LEDs light up to indicate the level of charge in the batteries.

- A lighted green LED indicates an adequate charge level.
- A lighted yellow LED indicates the need for charging soon.
- A lighted red LED warns that the battery charge level is low; all functional operations become non-functional until the batteries are recharged.

### 5. Emergency Stop Button

When pushed in, the **EMERGENCY STOP (5)** button disconnects electrical power to the ground (lower), and platform (upper) control panels. The **EMERGENCY STOP (5)** button should only be pressed (pushed) in to immediately stop all boom functions. To resume control, pull the **EMERGENCY STOP (5)** button out.

### 6. Speed Buttons

The **SPEED (6)** buttons are located along the lower right side of the control panel, one of the speed buttons must be pressed (pushed) in and held while selecting the various boom functions. There are four speeds that range from fast (**RABBIT**), to slow (**TURTLE**), available to help control the positioning of the Boom.

### 7-8. Boom Rotation Buttons

Pressing (pushing) in and holding a desired **SPEED (6)** button and the **BOOM ROTATION (7)** button at the same time enables the boom to rotate in the **CLOCKWISE** direction. Pressing (pushing) and holding a desired **SPEED (6)** button and the **BOOM ROTATION (8)** button at the same time enables the boom to rotate in the **COUNTER CLOCKWISE** direction. The boom will rotate through 700° of Non-Continuous rotation until the buttons are released or the stop is reached.

### 9-10. Boom Raise / Down Buttons

Pressing (pushing) and holding a desired **SPEED (6)** button and the **BOOM RAISE (9)** button at the same time will raise the boom. Pressing a desired **SPEED (6)** button and the **BOOM DOWN (10)** button at the same time will lower the boom. Boom motion continues until the buttons are released or until each boom reaches a hard stop or a safe travel limit.

### 11-12. Boom Extend / Retract Buttons

Pressing (pushing) and holding a desired **SPEED (6)** button and the **BOOM EXTEND (11)** button at the same time extends the Boom. Pressing (pushing) and holding a desired **SPEED (6)** button and the **BOOM RETRACT (12)** button at the same time retracts the Boom. Boom motion continues until the buttons are released or until the Boom reaches a hard stop or a safe travel limit.

### 13-14. Platform Tilt Buttons

Press (push) and hold any **SPEED (6)** button and the desired **PLATFORM TILT UP (13)** or **PLATFORM TILT DOWN (14)** button at the same time to level the work platform (this levels the platform only, NOT the aerial work platform).

### Outlet

An outlet has been provided as a power source for running electrical power tools, while in the work platform. The power plug is located on the trailer frame, in front of the accessory equipment stowage plate. A connecting power cord **must** be plugged into a suitable power source. The outlet is rated for a 15-ampere load. **DO NOT** overload the accessory power circuit.

## NORMAL OPERATING PROCEDURE

Become familiar with the location and function of all controls. Learn to smoothly **START** and **STOP** all boom functions.

Perform the following procedures to operate the Haulotte Group Telescoping Boom Lift.

- Read and obey all safety precautions and operating instructions, as well as all Federal, State, and Local codes and regulations.
- Conduct a Pre-Operation Inspection by performing all recommended Daily Service Checks. Refer to “Equipment Maintenance” Section of this manual.
- Position the aerial work platform at the work area. Make sure the aerial work platform is on a firm and level surface and there are no potential hazards such as overhead obstructions or electrically charged conductors. **DO NOT** operate the aerial work platform if such hazards exist.
- Apply the aerial work platform parking brake or chock the wheels.
- Lower the **TONGUE JACK / DOLLY WHEEL** and unhitch the aerial work platform from the tow vehicle.

### **WARNING**

Failing to unhitch the aerial work platform before operation may lead to damage to equipment or tow vehicle and makes the aerial work platform unstable; this could result in death or serious injury.

- Release the boom travel latch by raising the latch handle and swinging the clasp down. Refer to Figure 3-3.



Figure 3-3. Boom Travel Latch

## NORMAL OPERATING PROCEDURE (CONTINUED)

- Release the **PLATFORM TRAVEL LATCH** by lifting up on the handle, and pivoting the platform upright. Refer to Figure 3-4.



Figure 3-4. Platform Travel Latch

- PLATFORM LOCKING PINS** will engage (protrude through) in the pivot locking holes on the **PLATFORM MOUNT** when the **PLATFORM** is in a full upright position. Verify that the **PLATFORM** is locked into place. To release the **LOCKING PINS** squeeze the **LATCH KNOBS** together.
- Verify that the **PLATFORM** is properly attached to the **PLATFORM MOUNT** on the boom end. The **RETAINING PIN** should be fully inserted through the **PLATFORM** and the **PLATFORM MOUNT** on the boom end. Refer to Figure 3-5.

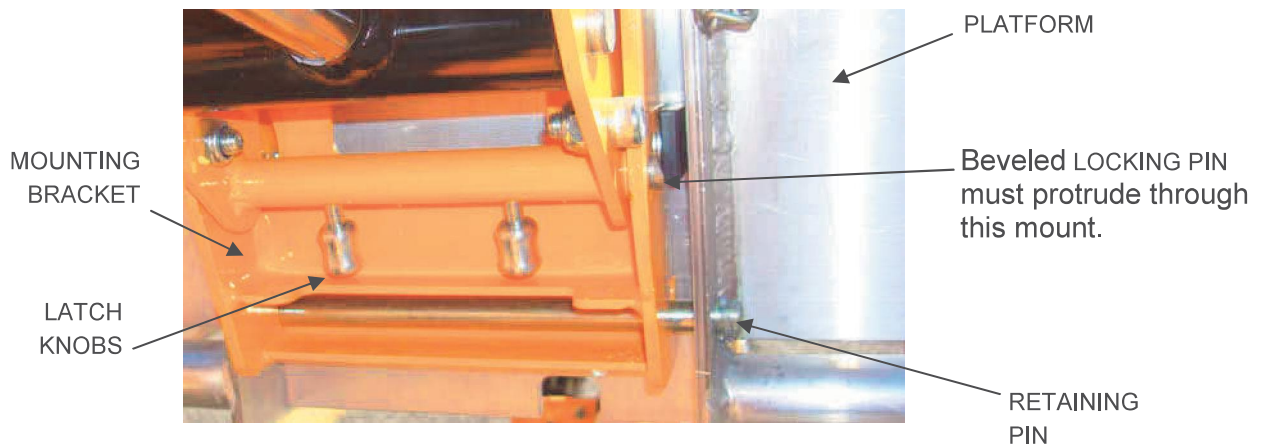

Figure 3-5. Platform Locking Pins



### WARNING

Failure to verify proper attachment of the platform to the boom end could cause the platform to separate from the boom; this could result in death or serious injury.

## NORMAL OPERATING PROCEDURE (CONTINUED)

- At the ground (lower) control panel, turn the **KEY SWITCH (1)** counter clockwise to the **GROUND CONTROLS (1a)** icon. If power does not come on, make sure that both of the **EMERGENCY STOP** buttons; **GROUND (6)**, and **PLATFORM (5)**, are pulled out and the main power disconnect plug is plugged in.
- The control microprocessor will perform self-diagnostics to test the operating system. After several seconds, the **DISPLAY PANEL** window will read:

### HAULOTTE GROUP ACCESS SOLUTIONS

- Monitor the battery condition indicator during operation and charge the batteries as necessary.
- Extend the four outriggers individually, or for simultaneous extension use the **AUTO LEVEL (23)** button on the ground (lower) control panel. When the aerial work platform is leveled properly, a buzzer will sound, the two LEDs at each **OUTRIGGER (25 and 26)** button, and the LED at the **AUTO LEVEL (23)** button will be lit. See Figure 3-6.

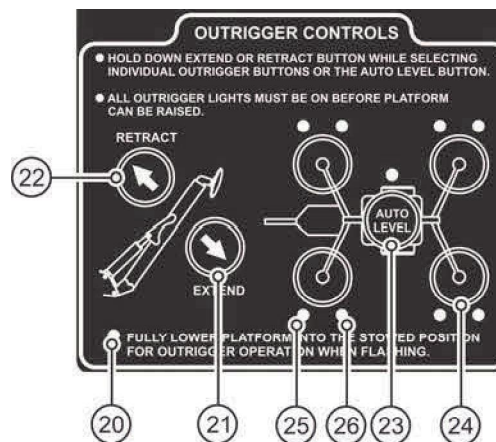

Figure 3-6. Outrigger Controls

- **Auto Level:** Press (push) and hold the **EXTEND (21)** and **AUTO LEVEL (23)** buttons at the same time.
- **Manual Level:** Extend the two outriggers closest to the trailer coupler first. Lower the front pair of outriggers by pressing (pushing) the **EXTEND (21)** button and the two front **OUTRIGGER** buttons at the same time. Lower the back pair of outriggers by pressing (pushing) the **EXTEND (21)** button and the two back **OUTRIGGER** buttons at the same time.
- Verify that the **AUTO LEVEL (23)** indicator LED is lit. If the **AUTO LEVEL (23)** indicator is not lit, the aerial work platform may not be level, and the weight of the machine may not be on the outrigger foot pad.

**NOTE:** If the boom is not level or if one or more outriggers are not supporting the machines load, the safety interlock system prevents all telescoping boom operations.

**NOTE:** The Range of Motion Diagram at the ground (lower) and platform (upper) control stations displays the range of platform motion (safe operating zone) facing away from the trailer tongue. Verify that the operating zone is clear of obstructions through 700° of Non-Continuous rotation.



## NORMAL OPERATING PROCEDURE (CONTINUED)

- Use the ground (lower) control panel to operate the boom lift functions. Raise, lower, extend and rotate the boom by pressing (pushing) and holding the desired **SPEED** and function buttons at the same time.
- Fully lower the boom onto the boom rest to enter the platform using a three (3) point contact (both hands and one foot).
- Raise the safety bar and enter the work platform by using a three (3) point contact (both hands and one foot). Put on a safety harness and attach the lanyard to the **ANCHORAGE** (attachment point) on the side of the platform support beam.
- Should the platform become tilted out of the normal vertical axis, press (push) and hold the desired **SPEED (6)** button and one of the **PLATFORM TILT (16)** or **(17)** buttons at the same time to level the platform back into the normal vertical axis.
- Use the platform (upper) control panel to operate the boom lift functions. Raise, lower, extend and rotate the boom by pressing (pushing) and holding the desired **SPEED (6)** and desired function buttons at the same time. Become familiar with the location and function of all controls. Learn to smoothly **START** and **STOP** all boom functions.
- When all aerial work platform operations are complete, fully retract the boom extension. Center the boom over the boom rest and fully lower the boom until seated in the “stowed” position for transport.

**NOTE:** Always fully retract, rotate and lower the boom to the “stowed” position before exiting the platform

- Turn the key switch to the **GROUND CONTROLS (1a)** position.
- Unfasten the safety harness and exit the platform by using a three (3) point contact (both hands and one foot).
- Disengage platform locking pins and return the platform to a “stowed” position.
- Engage the boom and platform travel latches.

**NOTE:** Refer back to earlier in this section to Figures 3-3 to 3-5 for a visual of these latches

- Turn the key switch to the ground controls position.
- Inspect the area beneath the aerial work platform and trailer for obstructions before retracting outriggers. Press (push) and hold the outrigger **RETRACT (22)** button and the **AUTO LEVEL (23)** button until all outriggers are fully retracted to their “stowed” (upright) positions.

**NOTE:** Safety switches prevent outrigger retraction until the boom is completely lowered and in the “stowed” position.

- At the ground (lower) control panel turn the **KEY SWITCH (1)** to the vertical (power “OFF”) position, and remove the key.

## MANUAL BOOM OPERATION

Manual retraction, rotation and lowering functions allow the boom to be moved and lowered during hydraulic power interruption or failure.

The following procedures for manual retraction, rotation and lowering require a person on the ground to operate the manual controls and hand pump.

The hydraulic hand pump is located in the pump compartment. In case of a power failure, the hand pump and selected hydraulic valves can be used to manually retract the boom or rotate the boom turntable.

### Manual Retraction

Begin manual retraction or rotation, by turning the proportional valve counterclockwise until it stops; insert the pump handle into the pump handle fitting. Pushing and holding the **RETRACT** button while simultaneously actuating the **HAND PUMP** will retract the extension boom.

Refer to Figure 3-7

### Manual Rotation

#### To rotate the TURNTABLE counterclockwise:

Push and hold the **ROTATION** button **IN** and simultaneously actuate **HAND PUMP**.

#### To rotate the TURNTABLE clockwise:

Pull the **ROTATION** button **OUT** and simultaneously actuate **HAND PUMP**.

**NOTE:** Turn the **PROPORTIONAL VALVE** clockwise to return it to its original position before lowering the telescoping boom or resuming normal operation.

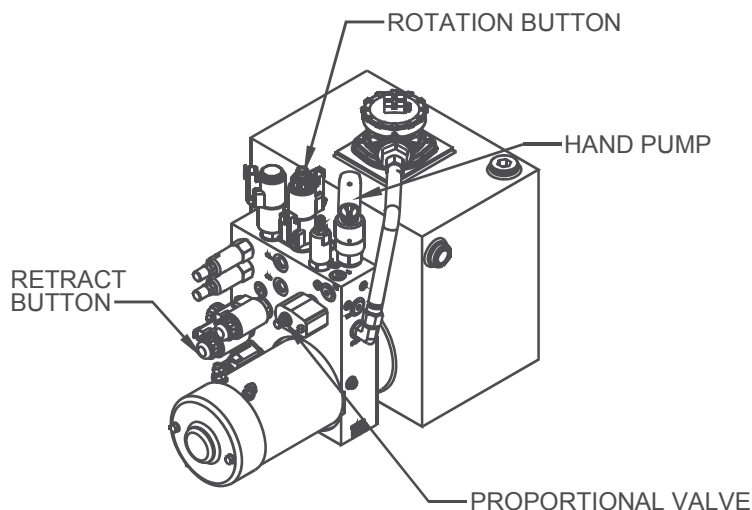

Figure 3-7. Hand Pump Controls for Manual Operation

## MANUAL BOOM OPERATION (CONTINUED)

### Manual Boom Lowering Procedure

The lift cylinder is equipped with a **MANUAL LOWERING VALVE**; this valve is found at the base of the lift cylinder. Use the **VALVE HANDLE** to lower the platform in case of a complete electrical power failure, a load shift, or any other emergency. To lower the work platform, pull the **VALVE HANDLE** forward, and continue pulling until the boom is completely lowered. Refer to Figure 3-8.

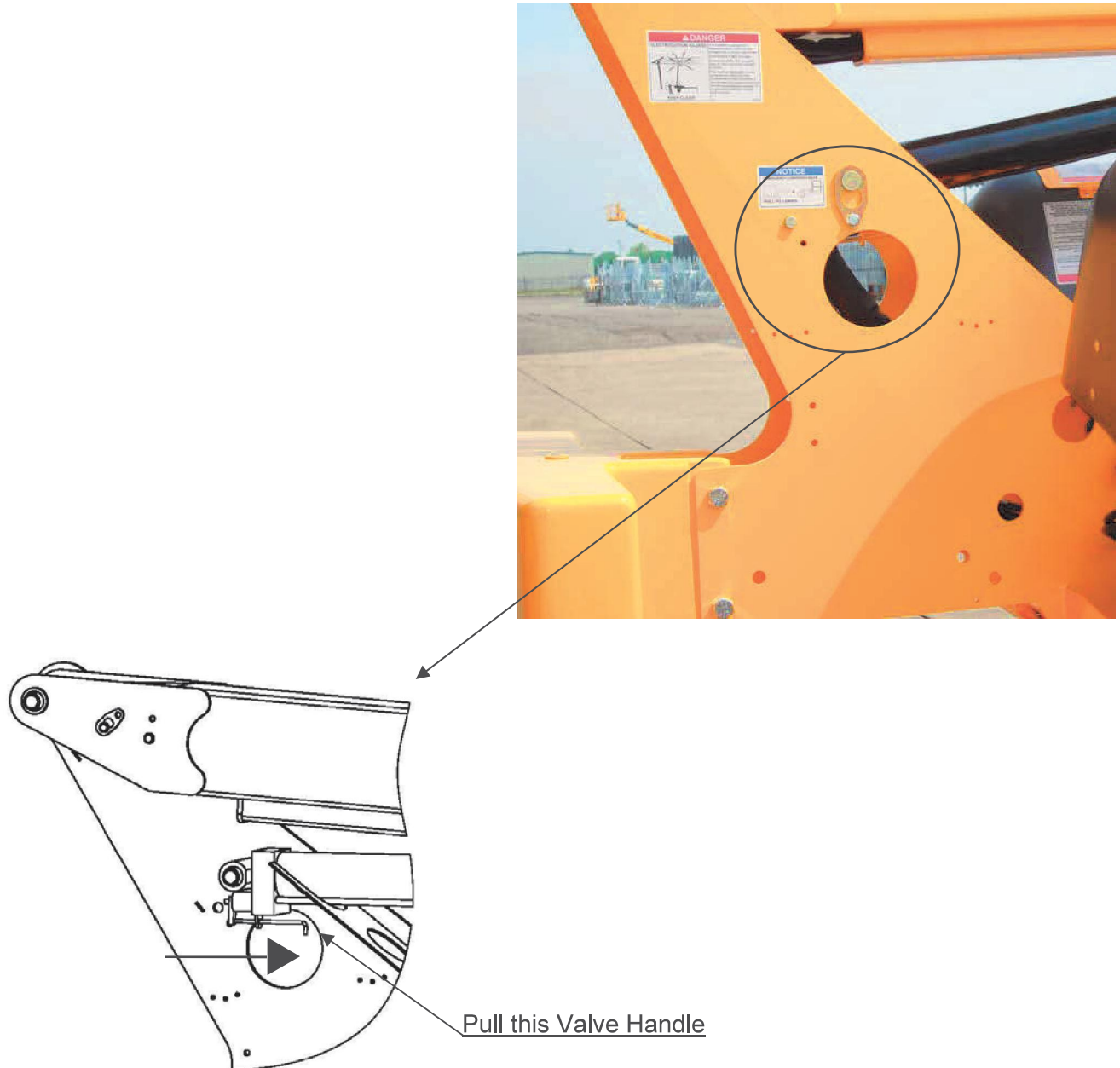

Figure 3-8. Manual Boom Lowering Valve

## TOWING THE AERIAL WORK PLATFORM

The aerial work platform trailer includes a single axle, two-inch ball hitch, hydraulic surge brakes, mechanical parking brake, safety chains, brake lights and side marker lights. Proper aerial work platform transport requires the proper attachment and inspection of these components before towing.

**Verify the following before towing the aerial work platform. Make adjustments as necessary.**

- The **TONGUE JACK / DOLLY WHEEL** and outriggers are in their travel positions. The **TONGUE JACK / DOLLY WHEEL** is rotated up so that the **TONGUE JACK / DOLLY WHEEL** assembly is parallel with the tongue tube; the outrigger cylinders are fully retracted.
- Both travel latches (boom and platform) are engaged, securing the boom in its fully “stowed” positions.
- All on-board equipment is secured.
- The key switch is in the “OFF” position. Remove the key.
- The parking brake is disengaged. When the parking brake is engaged it is parallel with the tongue tube, when disengaged it is perpendicular to the tongue.
- The trailer tires are adequately and evenly inflated. See the side wall of the tire for proper inflation

Periodically check the Wheel Nut torque according to manufacturer’s recommendations. Refer to the Monthly Service check section, in the Equipment Maintenance section of this manual.

**NEVER** tow an aerial work platform with worn or damaged wheel components.

### NOTICE

Prior to towing, while the trailer wheels are elevated for aerial work platform operation, inspect for loose wheels and for wheel lug wear. If a loose wheel mounting is suspected, remove and inspect wheel lugs for damage.



### CAUTION

Obtain, read and obey all recommendations set forth by the tow vehicle manufacturer before attempting to transport aerial work platform. Verify that aerial work platform weight does not exceed the vehicle’s towing capacity. Exceeding the tow vehicle’s rated capacity may result in damage to tow vehicle or aerial work platform.

## TOWING THE AERIAL WORK PLATFORM (CONTINUED)

### Procedure to hitch and tow the aerial work platform.

Back the tow vehicle to the trailer. Verify that the ball and hitch are aligned and that the trailer hitch has proper clearance above the ball. Refer to Figure 3-9.

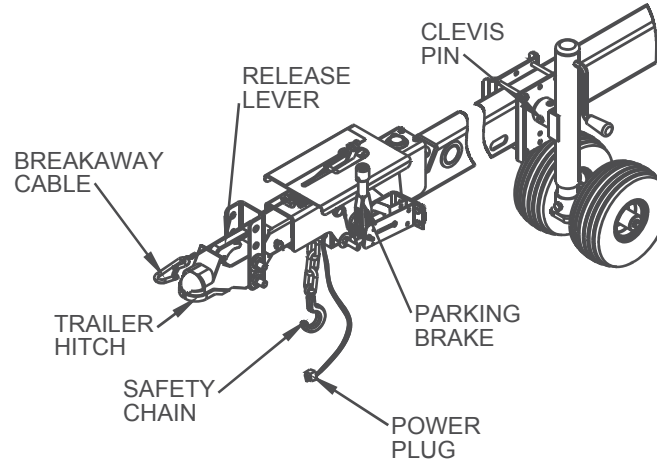

**Figure 3-9. Trailer Hitching**

- Lift the **RELEASE LEVER** on the **TRAILER HITCH**, and lower the hitch onto the ball using the **TONGUE JACK / DOLLY WHEEL**. Push down on the **RELEASE LEVER** to secure the ball. Refer to Figure 3-8.
- Use the **TONGUE JACK / DOLLY WHEEL** to verify that the coupling is secure.  
**NOTE:** If using the jack raises the bumper of the tow vehicle 2-3 inches, the ball hitch coupling is secure.
- Release the **PARKING BRAKE** by rotating the handle down until it is parallel with the tongue tube.
- On the **TONGUE JACK / DOLLY WHEEL**, pull the **CLEVIS PIN**, and swivel the **TONGUE JACK / DOLLY WHEEL** 90° to the travel position. Re-engage the **CLEVIS PIN**.
- Attach the safety chains to the tow vehicle. Verify that the chains cross under the trailer tongue.



### CAUTION

**Failure to attach safety chains properly before towing will allow trailer tongue to drop in case of ball hitch failure, resulting in damage to trailer and equipment.**

- For models with the breakaway cable; connect it to the tow vehicle. Leave adequate slack to prevent brakes from dragging.
- Connect the trailer lights to the tow vehicle power plug.