

319D and 323D Compact Track Loader



OPERATOR'S MANUAL 319D and 323D Compact Track Loader OMT253019 ISSUE G3 (ENGLISH)

CALIFORNIA Proposition 65 Warning

Diesel engine exhaust and some of its constituents are known to the State of California to cause cancer, birth defects, and other reproductive harm.

If this product contains a gasoline engine:

⚠ WARNING

The engine exhaust from this product contains chemicals known to the State of California to cause cancer, birth defects or other reproductive harm.

The State of California requires the above two warnings.

Additional Proposition 65 Warnings can be found in this manual.

**Worldwide Construction
And Forestry Division**
LITHO IN U.S.A.

Introduction

Foreword

READ THIS MANUAL carefully to learn how to operate and service your machine correctly. Failure to do so could result in personal injury or equipment damage. This manual and safety signs on your machine may also be available in other languages. (See your John Deere dealer to order.)

THIS MANUAL SHOULD BE CONSIDERED a permanent part of your machine and should remain with the machine when you sell it.

MEASUREMENTS in this manual are given in both metric and customary U.S. unit equivalents. Use only correct replacement parts and fasteners. Metric and inch fasteners may require a specific metric or inch wrench.

RIGHT-HAND AND LEFT-HAND sides are determined by facing in the direction of forward travel.

WRITE PRODUCT IDENTIFICATION NUMBERS (P.I.N.) in the Machine Numbers section. Accurately record all the numbers to help in tracing the machine should it be stolen. Your dealer also needs these numbers when you order parts. File the identification numbers in a secure place off the machine.

WARRANTY is provided as part of John Deere's support program for customers who operate and maintain their equipment as described in this manual. The warranty is explained on the warranty certificate or statement which you should have received from your dealer.

This warranty provides you the assurance that John Deere will back its products where defects appear within the warranty period. In some circumstances, John Deere also provides field improvements, often without charge to the customer, even if the product is out of warranty. Should the equipment be abused, or modified to change its performance beyond the original factory specifications, the warranty will become void and field improvements may be denied. Setting fuel delivery above specifications or otherwise overpowering machines will result in such action.

If you are not the original owner of this machine, it is in your interest to contact your local John Deere dealer to inform them of this unit's serial number. This will help John Deere notify you of any issues or product improvements.

VD76477,00004EB -19-11JUN12-1/1

IMPORTANT

Warranty will not apply to engine and drivetrain failures resulting from unauthorized adjustments to this engine.

Unauthorized adjustments are in violation of the emissions regulations applicable to this engine and may result in substantial fines and penalties.

VD76477,000104D -19-27JUN12-1/1

EPA Non-road Emissions Control Warranty Statement—Compression Ignition

DXLOGOV1 —UN—28APR09



JOHN DEERE

U.S. AND CANADA EMISSION CONTROL WARRANTY STATEMENT YOUR WARRANTY RIGHTS AND OBLIGATIONS

To determine if the John Deere engine qualifies for the additional warranties set forth below, look for the "Emissions Control Information" label located on the engine. If the engine is operated in the United States or Canada and the Emissions Control information label states: "This engine complies with US EPA regulations for nonroad and stationary diesel engines", or "This engine conforms to US EPA nonroad compression-ignition regulations", refer to the "U.S. and Canada Emission Control Warranty Statement." If the engine is operated in California, and the label states: "This engine complies with US EPA and CARB regulations for nonroad diesel engines", or "This engine conforms to US EPA and California nonroad compression-ignition emission regulations", also refer to the "California Emission Control Warranty Statement."

Warranties stated on this certificate refer only to emissions-related parts and components of your engine. The complete engine warranty, less emissions-related parts and components, is provided separately. If you have any questions about your warranty rights and responsibilities, you should contact John Deere at 1-319-292-5400.

JOHN DEERE'S WARRANTY RESPONSIBILITY

John Deere warrants to the ultimate purchaser and each subsequent purchaser that this off-road diesel engine including all parts of its emission-control system was designed, built and equipped so as to conform at the time of the sale with Section 213 of the Clean Air Act and is free from defects in materials and workmanship which would cause the engine to fail to conform with applicable US EPA regulations for a period of five years from the date the engine is placed into service or 3,000 hours of operation, whichever first occurs.

Where a warrantable condition exists, John Deere will repair or replace, as it elects, any part or component with a defect in materials or workmanship that would increase the engine's emissions of any regulated pollutant within the stated warranty period at no cost to you, including expenses related to diagnosing and repairing or replacing emission-related parts. Warranty coverage is subject to the limitations and exclusions set forth herein. Emission-related components include engine parts developed to control emissions related to the following:

Air-Induction System	Aftertreatment Devices
Fuel System	Crankcase Ventilation Valves
Ignition System	Sensors
Exhaust Gas Recirculation Systems	Engine Electronic Control Units

EMISSION WARRANTY EXCLUSIONS

John Deere may deny warranty claims for malfunctions or failures caused by:

- Non-performance of maintenance requirements listed in the Operator's Manual
- The use of the engine/equipment in a manner for which it was not designed
- Abuse, neglect, improper maintenance or unapproved modifications or alterations
- Accidents for which it does not have responsibility or by acts of God

The off-road diesel engine is designed to operate on diesel fuel as specified in the Fuels, Lubricants and Coolants section in the Operators Manual. Use of any other fuel can harm the emissions control system of the engine/equipment and is not approved for use.

To the extent permitted by law John Deere is not liable for damage to other engine components caused by a failure of an emission-related part, unless otherwise covered by standard warranty.

THIS WARRANTY IS EXPRESSLY IN LIEU OF ANY OTHER WARRANTIES, EXPRESS OR IMPLIED, INCLUDING ANY WARRANTY OF MERCHANTABILITY OR FITNESS FOR A PARTICULAR PURPOSE. REMEDIES UNDER THIS WARRANTY ARE LIMITED TO THE PROVISIONS OF MATERIAL AND SERVICES AS SPECIFIED HEREIN. WHERE PERMITTED BY LAW, NEITHER JOHN DEERE NOR ANY AUTHORIZED JOHN DEERE ENGINE DISTRIBUTOR, DEALER, OR REPAIR FACILITY OR ANY COMPANY AFFILIATED WITH JOHN DEERE WILL BE LIABLE FOR INCIDENTAL OR CONSEQUENTIAL DAMAGES.

Emission_CI_EPA (18Dec09)

Continued on next page

DX,EMISSIONS,EPA -19-12DEC12-1/2

Introduction



JOHN DEERE

U.S. AND CANADA EMISSION CONTROL WARRANTY STATEMENT YOUR WARRANTY RIGHTS AND OBLIGATIONS

To determine if the John Deere engine qualifies for the additional warranties set forth below, look for the "Emissions Control Information" label located on the engine. If the engine is operated in the United States or Canada and the Emissions Control information label states: "This engine complies with US EPA regulations for nonroad and stationary diesel engines", or "This engine conforms to US EPA nonroad compression-ignition regulations", refer to the "U.S. and Canada Emission Control Warranty Statement." If the engine is operated in California, and the label states: "This engine complies with US EPA and CARB regulations for nonroad diesel engines", or "This engine conforms to US EPA and California nonroad compression-ignition emission regulations", also refer to the "California Emission Control Warranty Statement."

Warranties stated on this certificate refer only to emissions-related parts and components of your engine. The complete engine warranty, less emissions-related parts and components, is provided separately. If you have any questions about your warranty rights and responsibilities, you should contact John Deere at 1-319-292-5400.

JOHN DEERE'S WARRANTY RESPONSIBILITY

John Deere warrants to the ultimate purchaser and each subsequent purchaser that this off-road diesel engine including all parts of its emission-control system was designed, built and equipped so as to conform at the time of the sale with Section 213 of the Clean Air Act and is free from defects in materials and workmanship which would cause the engine to fail to conform with applicable US EPA regulations for a period of five years from the date the engine is placed into service or 3,000 hours of operation, whichever first occurs.

Where a warrantable condition exists, John Deere will repair or replace, as it elects, any part or component with a defect in materials or workmanship that would increase the engine's emissions of any regulated pollutant within the stated warranty period at no cost to you, including expenses related to diagnosing and repairing or replacing emission-related parts. Warranty coverage is subject to the limitations and exclusions set forth herein. Emission-related components include engine parts developed to control emissions related to the following:

Air-Induction System	Aftertreatment Devices
Fuel System	Crankcase Ventilation Valves
Ignition System	Sensors
Exhaust Gas Recirculation Systems	Engine Electronic Control Units

EMISSION WARRANTY EXCLUSIONS

John Deere may deny warranty claims for malfunctions or failures caused by:

- Non-performance of maintenance requirements listed in the Operator's Manual
- The use of the engine/equipment in a manner for which it was not designed
- Abuse, neglect, improper maintenance or unapproved modifications or alterations
- Accidents for which it does not have responsibility or by acts of God

The off-road diesel engine is designed to operate on diesel fuel as specified in the Fuels, Lubricants and Coolants section in the Operators Manual. Use of any other fuel can harm the emissions control system of the engine/equipment and is not approved for use.

To the extent permitted by law John Deere is not liable for damage to other engine components caused by a failure of an emission-related part, unless otherwise covered by standard warranty.

THIS WARRANTY IS EXPRESSLY IN LIEU OF ANY OTHER WARRANTIES, EXPRESS OR IMPLIED, INCLUDING ANY WARRANTY OF MERCHANTABILITY OR FITNESS FOR A PARTICULAR PURPOSE. REMEDIES UNDER THIS WARRANTY ARE LIMITED TO THE PROVISIONS OF MATERIAL AND SERVICES AS SPECIFIED HEREIN. WHERE PERMITTED BY LAW, NEITHER JOHN DEERE NOR ANY AUTHORIZED JOHN DEERE ENGINE DISTRIBUTOR, DEALER, OR REPAIR FACILITY OR ANY COMPANY AFFILIATED WITH JOHN DEERE WILL BE LIABLE FOR INCIDENTAL OR CONSEQUENTIAL DAMAGES.

Emission_CI_EPA (18Dec09)

DX,EMISSIONS,EPA -19-12DEC12-2/2

TS1721 —UN—15JUL13

CARB Non-road Emissions Control Warranty Statement—Compression Ignition

DXLOGOV1 —UN—28APR09



JOHN DEERE

CALIFORNIA EMISSIONS CONTROL WARRANTY STATEMENT YOUR WARRANTY RIGHTS AND OBLIGATIONS

To determine if the John Deere engine qualifies for the additional warranties set forth below, look for the “Emission Control Information” label located on the engine. If the engine is operated in the United States or Canada and the engine label states: “This engine complies with US EPA regulations for nonroad and stationary diesel engines”, or “This engine complies with US EPA regulations for stationary emergency diesel engines”, refer to the “U.S. and Canada Emission Control Warranty Statement.” If the engine is operated in California, and the engine label states: “This engine complies with US EPA and CARB regulations for nonroad diesel engines” also refer to the “California Emissions Control Warranty Statement.”

Warranties stated on this certificate refer only to emissions-related parts and components of your engine. The complete engine warranty, less emission-related parts and components, is provided separately. If you have any questions about your warranty rights and responsibilities, you should contact John Deere at 1-319-292-5400.

CALIFORNIA EMISSIONS CONTROL WARRANTY STATEMENT:

The California Air Resources Board (CARB) is pleased to explain the emission-control system warranty on 2013 through 2015 off-road diesel engines. In California, new off-road engines must be designed, built and equipped to meet the State’s stringent anti-smog standards. John Deere must warrant the emission control system on your engine for the periods of time listed below provided there has been no abuse, neglect or improper maintenance of your engine.

Your emission control system may include parts such as the fuel injection system and the air induction system. Also included may be hoses, belts, connectors and other emission-related assemblies.

John Deere warrants to the ultimate purchaser and each subsequent purchaser that this off-road diesel engine was designed, built, and equipped so as to conform at the time of sale with all applicable regulations adopted by CARB and is free from defects in materials and workmanship which would cause the failure of a warranted part to be identical in all material respects to the part as described in John Deere’s application for certification for a period of five years from the date the engine is delivered to an ultimate purchaser or 3,000 hours of operation, whichever occurs first for all engines rated at 19 kW and greater. In the absence of a device to measure hours of use, the engine shall be warranted for a period of five years.

EMISSIONS WARRANTY EXCLUSIONS:

John Deere may deny warranty claims for failures caused by the use of an add-on or modified part which has not been exempted by the CARB. A modified part is an aftermarket part intended to replace an original emission-related part which is not functionally identical in all respects and which in any way affects emissions. An add-on part is any aftermarket part which is not a modified part or a replacement part.

In no event will John Deere, any authorized engine distributor, dealer, or repair facility, or any company affiliated with John Deere be liable for incidental or consequential damage.

Introduction

JOHN DEERE'S WARRANTY RESPONSIBILITY:

Where a warrantable condition exists, John Deere will repair or replace, as it elects, your off-road diesel engine at no cost to you, including diagnosis, parts or labor. Warranty coverage is subject to the limitations and exclusions set forth herein. The off-road diesel engine is warranted for a period of five years from the date the engine is delivered to an ultimate purchaser or 3,000 hours of operation, whichever occurs first. The following are emissions-related parts:

Air Induction System

- Intake manifold
- Turbocharger
- Charge air cooler

Fuel Metering system

- Fuel injection system

Exhaust Gas Recirculation

- EGR valve

Catalyst or Thermal Reactor Systems

- Catalytic converter
- Exhaust manifold

Emission control labels

Particulate Controls

- Any device used to capture particulate emissions
- Any device used in the regeneration of the capturing system
- Enclosures and manifolding
- Smoke Puff Limiters

Positive Crankcase Ventilation (PCV) System

- PCV valve
- Oil filler cap

Advanced Oxides of Nitrogen (NOx) Controls

- NOx absorbers and catalyts

SCR systems and urea containers/dispensing systems

Miscellaneous Items used in Above Systems

- Electronic control units, sensors, actuators, wiring harnesses, hoses, connectors, clamps, fittings, gasket, mounting hardware

Any warranted emissions-related part scheduled for replacement as required maintenance is warranted by John Deere for the period of time prior to the first scheduled replacement point for the part. Any warranted emissions-related part not scheduled for replacement as required maintenance or scheduled only for regular inspection is warranted by John Deere for the stated warranty period.

OWNER'S WARRANTY RESPONSIBILITIES:

As the off-road diesel engine owner you are responsible for the performance of the required maintenance listed in your Operator's Manual. John Deere recommends that the owner retain all receipts covering maintenance on the off-road diesel engine, but John Deere cannot deny warranty solely for the lack of receipts or for the owner's failure to ensure the performance of all scheduled maintenance. However, as the off-road diesel engine owner, you should be aware that John Deere may deny you warranty coverage if your off-road diesel engine or a part has failed due to abuse, neglect, improper maintenance or unapproved modifications.

The off-road diesel engine is designed to operate on diesel fuel as specified in the Fuels, Lubricants and Coolants section in the Operators Manual. Use of any other fuel may result in the engine no longer operating in compliance with applicable emissions requirements.

The owner is responsible for initiating the warranty process, and should present the machine to the nearest authorized John Deere dealer as soon as a problem is suspected. The warranty repairs should be completed by the authorized John Deere dealer as quickly as possible.

Emissions regulations require the customer to bring the unit to an authorized servicing dealer when warranty service is required. As a result, John Deere is NOT liable for travel or mileage on emissions warranty service calls.

Emission_CI_CARB (19Sep12)

Continued on next page

DX,EMISSIONS,CARB -19-12DEC12-2/4



JOHN DEERE

**CALIFORNIA EMISSIONS CONTROL WARRANTY STATEMENT
YOUR WARRANTY RIGHTS AND OBLIGATIONS**

To determine if the John Deere engine qualifies for the additional warranties set forth below, look for the "Emission Control Information" label located on the engine. If the engine is operated in the United States or Canada and the engine label states: "This engine complies with US EPA regulations for nonroad and stationary diesel engines", or "This engine complies with US EPA regulations for stationary emergency diesel engines", refer to the "U.S. and Canada Emission Control Warranty Statement." If the engine is operated in California, and the engine label states: "This engine complies with US EPA and CARB regulations for nonroad diesel engines" also refer to the "California Emissions Control Warranty Statement."

Warranties stated on this certificate refer only to emissions-related parts and components of your engine. The complete engine warranty, less emission-related parts and components, is provided separately. If you have any questions about your warranty rights and responsibilities, you should contact John Deere at 1-319-292-5400.

CALIFORNIA EMISSIONS CONTROL WARRANTY STATEMENT:

The California Air Resources Board (CARB) is pleased to explain the emission-control system warranty on 2013 through 2015 off-road diesel engines. In California, new off-road engines must be designed, built and equipped to meet the State's stringent anti-smog standards. John Deere must warrant the emission control system on your engine for the periods of time listed below provided there has been no abuse, neglect or improper maintenance of your engine.

Your emission control system may include parts such as the fuel injection system and the air induction system. Also included may be hoses, belts, connectors and other emission-related assemblies.

John Deere warrants to the ultimate purchaser and each subsequent purchaser that this off-road diesel engine was designed, built, and equipped so as to conform at the time of sale with all applicable regulations adopted by CARB and is free from defects in materials and workmanship which would cause the failure of a warranted part to be identical in all material respects to the part as described in John Deere's application for certification for a period of five years from the date the engine is delivered to an ultimate purchaser or 3,000 hours of operation, whichever occurs first for all engines rated at 19 kW and greater. In the absence of a device to measure hours of use, the engine shall be warranted for a period of five years.

EMISSIONS WARRANTY EXCLUSIONS:

John Deere may deny warranty claims for failures caused by the use of an add-on or modified part which has not been exempted by the CARB. A modified part is an aftermarket part intended to replace an original emission-related part which is not functionally identical in all respects and which in any way affects emissions. An add-on part is any aftermarket part which is not a modified part or a replacement part.

In no event will John Deere, any authorized engine distributor, dealer, or repair facility, or any company affiliated with John Deere be liable for incidental or consequential damage.

Continued on next page

DX,EMISSIONS,CARB -19-12DEC12-3/4

TS1722—UN—17DEC12

Introduction

JOHN DEERE'S WARRANTY RESPONSIBILITY:

Where a warrantable condition exists, John Deere will repair or replace, as it elects, your off-road diesel engine at no cost to you, including diagnosis, parts or labor. Warranty coverage is subject to the limitations and exclusions set forth herein. The off-road diesel engine is warranted for a period of five years from the date the engine is delivered to an ultimate purchaser or 3,000 hours of operation, whichever occurs first. The following are emissions-related parts:

Air Induction System

- Intake manifold
- Turbocharger
- Charge air cooler

Fuel Metering system

- Fuel injection system

Exhaust Gas Recirculation

- EGR valve

Catalyst or Thermal Reactor Systems

- Catalytic converter
- Exhaust manifold

Emission control labels

Particulate Controls

- Any device used to capture particulate emissions
- Any device used in the regeneration of the capturing system
- Enclosures and manifolding
- Smoke Puff Limiters

Positive Crankcase Ventilation (PCV) System

- PCV valve
- Oil filler cap

Advanced Oxides of Nitrogen (NOx) Controls

- NOx absorbers and catalyts

SCR systems and urea containers/dispensing systems

Miscellaneous Items used in Above Systems

- Electronic control units, sensors, actuators, wiring harnesses, hoses, connectors, clamps, fittings, gasket, mounting hardware

Any warranted emissions-related part scheduled for replacement as required maintenance is warranted by John Deere for the period of time prior to the first scheduled replacement point for the part. Any warranted emissions-related part not scheduled for replacement as required maintenance or scheduled only for regular inspection is warranted by John Deere for the stated warranty period.

OWNER'S WARRANTY RESPONSIBILITIES:

As the off-road diesel engine owner you are responsible for the performance of the required maintenance listed in your Operator's Manual. John Deere recommends that the owner retain all receipts covering maintenance on the off-road diesel engine, but John Deere cannot deny warranty solely for the lack of receipts or for the owner's failure to ensure the performance of all scheduled maintenance. However, as the off-road diesel engine owner, you should be aware that John Deere may deny you warranty coverage if your off-road diesel engine or a part has failed due to abuse, neglect, improper maintenance or unapproved modifications.

The off-road diesel engine is designed to operate on diesel fuel as specified in the Fuels, Lubricants and Coolants section in the Operators Manual. Use of any other fuel may result in the engine no longer operating in compliance with applicable emissions requirements.

The owner is responsible for initiating the warranty process, and should present the machine to the nearest authorized John Deere dealer as soon as a problem is suspected. The warranty repairs should be completed by the authorized John Deere dealer as quickly as possible.

Emissions regulations require the customer to bring the unit to an authorized servicing dealer when warranty service is required. As a result, John Deere is NOT liable for travel or mileage on emissions warranty service calls.

Emission_CI_CARB (19Sep12)

DX,EMISSIONS,CARB -19-12DEC12-4/4

TS1723 —UN—15JUL13

Technical Information Feedback Form

We need your help to continually improve our technical publications. Please copy this page and FAX or mail your comments, ideas and improvements.

SEND TO: John Deere Dubuque Works
18600 South John Deere Road
Attn: Publications, Dept. 324
Dubuque, IA 52004-0538
USA

FAX NUMBER: 1-563-589-5800 (USA)

Publication Number: _____

Page Number: _____

Ideas, Comments: _____

Name: _____

Phone: _____

Email Address: _____

THANK YOU!

Introduction

Contents

Page	Page
Safety—Safety and Operator Conveniences	
Safety and Operator Convenience Features 1-1-1	
Safety—General Precautions	
Recognize Safety Information 1-2-1	
Follow Safety Instructions 1-2-1	
Operate Only If Qualified 1-2-1	
Wear Protective Equipment 1-2-2	
Avoid Unauthorized Machine Modifications 1-2-2	
Inspect Machine 1-2-2	
Stay Clear of Moving Parts 1-2-2	
Avoid High-Pressure Fluids 1-2-3	
Avoid High-Pressure Oils 1-2-3	
Work In Ventilated Area 1-2-4	
Prevent Fires 1-2-4	
Prevent Battery Explosions 1-2-5	
Handle Chemical Products Safely 1-2-5	
Dispose of Waste Properly 1-2-5	
Prepare for Emergencies 1-2-6	
Clean Debris from Machine 1-2-6	
Safety—Operating Precautions	
Use Steps and Handholds Correctly 1-3-1	
Start Only From Operator's Seat 1-3-1	
Use and Maintain Seat Belt 1-3-1	
Prevent Unintended Machine Movement 1-3-1	
Avoid Work Site Hazards 1-3-2	
Keep Riders Off Machine 1-3-2	
Avoid Backover Accidents 1-3-3	
Avoid Machine Tip Over 1-3-3	
Operating On Slopes 1-3-3	
Operating Or Traveling On Public Roads 1-3-4	
Inspect and Maintain ROPS 1-3-4	
Add and Operate Attachments Safely 1-3-4	
Safety—Maintenance Precautions	
Park and Prepare for Service Safely 1-4-1	
Service Cooling System Safely 1-4-1	
Remove Paint Before Welding or Heating 1-4-2	
Make Welding Repairs Safely 1-4-2	
Drive Metal Pins Safely 1-4-2	
Handle Cab Door Safely 1-4-3	
Safety—Safety Signs	
Replace Safety Signs 1-5-1	
Safety Signs 1-5-2	
Operation—Operator's Station	
Machine Control 2-1-1	
Control Panel 2-1-3	
Control Panel Functions 2-1-4	
Engagement and Monitor Unit Operation 2-1-6	
Engagement and Monitor Unit Display Messages 2-1-7	
Anti-Theft Security System Operation—If Equipped 2-1-8	
Reading Diagnostic Trouble Codes 2-1-11	
Gauges and Indicator Lights 2-1-11	
Gauge and Indicator Light Functions 2-1-12	
Auto Shutdown With Alarm 2-1-12	
Interlocking Seat Bar 2-1-13	
Cab Door—If Equipped 2-1-13	
Opening Side Windows—If Equipped 2-1-16	
Top Window 2-1-17	
Rear Window (Secondary Exit) 2-1-17	
Fire Extinguisher Location 2-1-17	
12-Volt Power Outlet 2-1-18	
Heating/Defrosting Controls—If Equipped 2-1-18	
Air Conditioning Controls—If Equipped 2-1-18	
Seat Adjustment 2-1-19	
Dome Light 2-1-20	
Horn Button—If Equipped 2-1-20	
Beacon—If Equipped 2-1-20	
Operation—Operating the Machine	
Before Starting Work 2-2-1	
Operator's Daily Machine Check Before Starting 2-2-1	
Entering and Exiting Skid Steer 2-2-2	
Engine Break-In Period 2-2-3	
Starting the Engine 2-2-3	
Cold Weather Starting 2-2-4	
Engine Block Heater—If Equipped 2-2-4	
Engine Speed Control 2-2-5	
Stopping the Engine 2-2-5	
Boom Lock 2-2-6	
Boom Release 2-2-7	
Steering—Manual Controls 2-2-8	
Operating Boom—Manual Controls 2-2-9	
Operating Bucket—Manual Controls 2-2-11	
Steering—EH Controls 2-2-12	
Operating Boom—EH Controls 2-2-14	

Continued on next page

Original Instructions. All information, illustrations and specifications in this manual are based on the latest information available at the time of publication. The right is reserved to make changes at any time without notice.

COPYRIGHT © 2013
DEERE & COMPANY
Moline, Illinois
All rights reserved.
A John Deere ILLUSTRATION © Manual
Previous Editions
Copyright © 2009, 2010, 2011

	Page		Page
Operating Bucket—EH Controls	2-2-16		
Operating Auxiliary Hydraulics	2-2-18		
Hydraulic System Pressure			
Release—EH Controls	2-2-21		
Hydraulic System Pressure			
Release—Manual Controls	2-2-21		
Using Attachment Mounting			
System—Quik-Tatch™	2-2-23		
Self Leveling Hydraulics—If Equipped	2-2-25		
High Flow Hydraulics—If Equipped	2-2-25		
Creep Mode Operation—If Equipped	2-2-26		
Auto Idle Operation.....	2-2-27		
Boom and Bucket Speed Settings—If			
Equipped	2-2-27		
Loading Machine On a Trailer	2-2-28		
Operation—Track Information			
Undercarriage Component Identification	2-3-1		
Rubber Track Structure	2-3-2		
Rubber Track Usage	2-3-3		
Sprocket Teeth Wear	2-3-4		
Normal Break-In	2-3-5		
Normal Track Wear in Dirt Conditions	2-3-5		
Rubber Track—Types of Damage	2-3-6		
Maintenance—Machine			
Diesel Fuel.....	3-1-1		
Lubricity of Diesel Fuel	3-1-1		
Handling and Storing Diesel Fuel	3-1-2		
Biodiesel Fuel	3-1-3		
Testing Diesel Fuel	3-1-4		
Minimizing the Effect of Cold Weather			
on Diesel Engines	3-1-5		
Operating in Cold Temperature Climates	3-1-6		
Alternative and Synthetic Lubricants	3-1-6		
Diesel Engine Break-In Oil	3-1-6		
Diesel Engine Oil—Interim Tier 4 and			
Stage III B Engines	3-1-7		
Engine Oil and Filter Service			
Intervals—Interim Tier 4 and Stage			
III B Engines	3-1-8		
Light Duty Diesel Engine Coolant (for			
diesel engines without wet sleeve			
cylinder liners)	3-1-9		
Drain Intervals for Diesel Engine Coolant.....	3-1-9		
John Deere COOL-GARD™ II Coolant			
Extender	3-1-10		
Supplemental Coolant Additives.....	3-1-10		
Operating in Warm Temperature Climates	3-1-11		
Additional Information About Diesel			
Engine Coolants and John Deere			
COOL-GARD™ II Coolant Extender	3-1-12		
Testing Diesel Engine Coolant.....	3-1-13		
Hydraulic and Hydrostatic Oil	3-1-13		
Hydrostatic Planetary Gear Case Oil.....	3-1-14		
Grease.....	3-1-14		
Maintenance—Periodic Maintenance			
Service Machine at Specified Intervals.....	3-2-1		
Fuel Tank	3-2-1		
Raising and Blocking Machine	3-2-2		
Raising Operator's Station.....	3-2-3		
Opening and Closing Engine Cover	3-2-4		
Engine Side Panels—Remove and Install.....	3-2-4		
Footwell Removal	3-2-6		
Fluid Analysis Program Test Kits and			
3-Way Coolant Test Kit.....	3-2-6		
Service Intervals	3-2-7		
Required Parts.....	3-2-8		
Maintenance—As Required			
Inspect and Clean Cooling Package	3-3-1		
Check and Clean Cab Fresh Air and			
Recirculation Air Filters—If Equipped	3-3-2		
Inspect and Clean Fuel Tank Vent Tube.....	3-3-2		
Check Coolant	3-3-3		
Maintenance—Every 10 Hours or Daily			
Check Engine Oil Level	3-4-1		
Check Hydraulic Reservoir Oil Level	3-4-1		
Check Coolant Level	3-4-2		
Check and Drain Water Separator Fuel Filter ...	3-4-2		
Maintenance—Initial Service - 50 Hours			
Change Hydrostatic Planetary Gear			
Case Oil (S.N. 192142—)	3-5-1		
Maintenance—Every 50 Hours			
Lubricate Boom Linkage, Cylinder			
Pivot Points, and Quik-Tatch™ Linkage.....	3-6-1		
Check Track Tension	3-6-2		
Maintenance—Initial Service - 250 Hours			
Change Engine Oil and Replace Filter	3-7-1		
Change Hydrostatic Planetary Gear			
Case Oil (S.N. —192141)	3-7-2		
Maintenance—Every 250 Hours			
Take Engine Oil Sample	3-8-1		
Maintenance—Every 500 Hours			
Change Engine Oil and Replace Filter	3-9-1		
Replace Fuel Filter and Water Separator	3-9-2		
Replace In-Line Fuel Filter	3-9-3		
Replace Primary Engine Air Filter	3-9-4		
Replace Hydraulic Oil Reservoir Breather.....	3-9-5		
Replace Hydraulic Oil Filter.....	3-9-5		
Lubricate Steering Linkage—If Equipped	3-9-6		
Drain Fuel Tank Sump.....	3-9-6		
Change Hydrostatic Planetary Gear			
Case Oil (S.N. —192141)	3-9-7		

Continued on next page

Page	Page
Take Fluid Samples3-9-7	Record Engine Serial Number.....4-5-1
Maintenance—Every 1000 Hours	Keep Proof of Ownership4-5-1
Check Coolant3-10-1	Keep Machines Secure4-5-1
Replace Secondary Engine Air Filter.....3-10-2	Miscellaneous—Specifications
Change Hydrostatic Planetary Gear	319D Machine Dimensions.....4-6-1
Case Oil (S.N. 192142—)3-10-3	319D Machine Specifications4-6-2
Change Hydraulic Reservoir Oil3-10-4	323D Machine Dimensions.....4-6-3
Maintenance—Every 6000 Hours	323D Machine Specifications4-6-4
Drain Cooling System.....3-11-1	319D and 323D Drain and Refill Capacities.....4-6-5
Flush Cooling System.....3-11-2	Rated Operating Capacity4-6-5
Fill Cooling System.....3-11-2	Pallet Fork Lift Chart.....4-6-5
Miscellaneous—Machine	
Do Not Service Control Valves,	
Cylinders, Pumps, or Motors.....4-1-1	
Precautions for Alternator and Regulator4-1-1	
Check Battery Electrolyte Level and Terminals ..4-1-2	
Handling, Checking, and Servicing	
Batteries Carefully4-1-4	
Using Battery Charger.....4-1-5	
Using Booster Batteries—12-Volt System4-1-5	
Removing Battery4-1-6	
Replacing Battery4-1-6	
Welding On Machine4-1-7	
Welding Near Electronic Control Units4-1-7	
Keep Electronic Control Unit	
Connectors Clean4-1-7	
Remove and Install Halogen Bulbs4-1-8	
Adding Rear Counterweights.....4-1-9	
Replacing Alternator Belt.....4-1-10	
Adjusting Boom and Bucket	
Linkage—Hands Only Machines.....4-1-10	
Adjusting Pedal Angle—Hand and	
Foot Machines.....4-1-11	
Replacing Fuses.....4-1-11	
Replacing Glow Plug Fuse4-1-12	
Hardware Torque Specifications.....4-1-13	
Unified Inch Bolt and Screw Torque Values.....4-1-13	
Metric Bolt and Screw Torque Values.....4-1-14	
Miscellaneous—Operational Checkout	
Operational Checkout.....4-2-1	
Miscellaneous—Troubleshooting	
Troubleshooting Procedure4-3-1	
Engine4-3-1	
Electrical System.....4-3-2	
Hydraulic System.....4-3-3	
Miscellaneous—Machine Storage	
Prepare Machine for Storage4-4-1	
Monthly Storage Procedure.....4-4-2	
Miscellaneous—Machine Numbers	
Record Product Identification Number (PIN)4-5-1	

Safety—Safety and Operator Conveniences

Safety and Operator Convenience Features

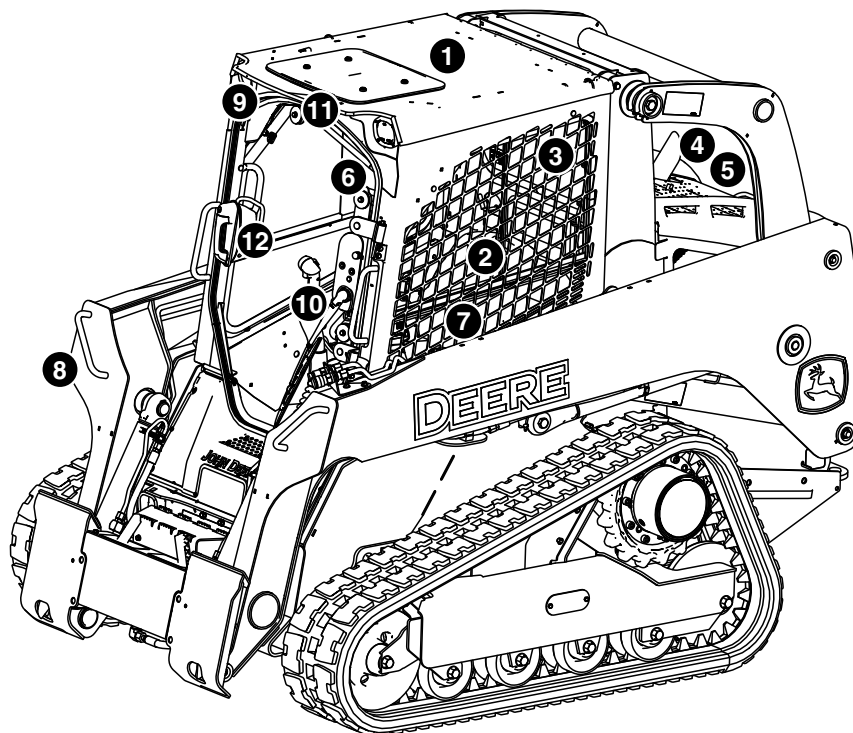

TX1063621

Please remember that the operator is the key to preventing accidents.

- 1. ROPS/FOPS Protection.** Structures designed to help protect the operator are certified to ISO and OSHA. Enclosure also deflects sun and rain.
- 2. Window Guarding.** Side screens prevent contact with a moving boom.
- 3. Secondary Exit.** The rear window provides an exit path if the front door is blocked.
- 4. Bypass Start Protection.** Shielding over the starter terminals helps prevent dangerous bypass starting.
- 5. Engine Fan Guard.** Enclosing the fan fully inside the cooling package helps prevent contact with rotating fan blades.
- 6. Loader Boom Service Lock.** A mechanical lock is provided for working on or around this machine with the boom raised.

7. Seat Belt with Automatic Retractor. Retractor helps protect the operator and keeps the belt and operator's station clean. A convenient integrated seat and shoulder belt system is also provided.

8. Handholds. Conveniently placed handholds make it easy to enter or exit the operator's station.

9. Independent Parking Brake. Electrically controlled parking brake engages whenever the engine is stopped.

10. Cab with Air Conditioner, Heater, and Defroster. Options are available.

11. Rearview Mirror. For operator convenience, a rearview mirror is available.

12. Swing Out Front Door. A sealed swing out front door is available. It allows the cab to be pressurized. Also provides easy access into cab and more headroom inside cab.

OUT4001,000046F -19-28OCT09-1/1

TX1063621—UN—02NOV09

Safety—General Precautions

Recognize Safety Information

This is the safety alert symbol. When you see this symbol on your machine or in this manual, be alert for the potential of personal injury.

Follow the precautions and safe operating practices highlighted by this symbol.

A signal word — DANGER, WARNING, or CAUTION — is used with the safety alert symbol. DANGER identifies the most serious hazards.

On your machine, DANGER signs are red in color, WARNING signs are orange, and CAUTION signs are yellow. DANGER and WARNING signs are located near specific hazards. General precautions are on CAUTION labels.



TX,RECOGNIZE -19-28JUN10-1/1

TI 33555 —UN—15APR13

TI 33558 —19—28AUG00

Follow Safety Instructions

Carefully read all safety messages in this manual and on your machine safety signs. Keep safety signs in good condition. Replace missing or damaged safety signs. Use this operator's manual for correct safety sign placement. Be sure new equipment components and repair parts include the current safety signs. Replacement safety signs are available from your John Deere dealer.

There can be additional safety information contained on parts and components sourced from suppliers that is not reproduced in this operator's manual.

Learn how to operate the machine and how to use controls properly. Do not let anyone operate without instruction.

Keep your machine in proper working condition. Unauthorized modifications to the machine may impair the function and/or safety and affect machine life.



If you do not understand any part of this manual and need assistance, contact your John Deere dealer.

VD76477,0000510 -19-01JUN12-1/1

TS201 —UN—15APR13

Operate Only If Qualified

Do not operate this machine unless the operator's manual has been read carefully, and you have been qualified by supervised training and instruction.

Operator should be familiar with the job site and surroundings before operating. Try all controls and

machine functions with the machine in an open area before starting to work.

Know and observe all safety rules that may apply to every work situation and work site.

TX03679,00016FA -19-03JAN07-1/1

Wear Protective Equipment

Guard against injury from flying pieces or metal or debris; wear goggles or safety glasses.

Wear close fitting clothing and safety equipment appropriate to the job.

Operating equipment safely requires the full attention of the operator. Do not wear radio or music headphones while operating machine.

Prolonged exposure to loud noise can cause impairment or loss of hearing. Wear suitable hearing protection such as earmuffs or earplugs to protect against objectionable or uncomfortable loud noises. Radio or music headphones are not suitable to use for hearing protection.

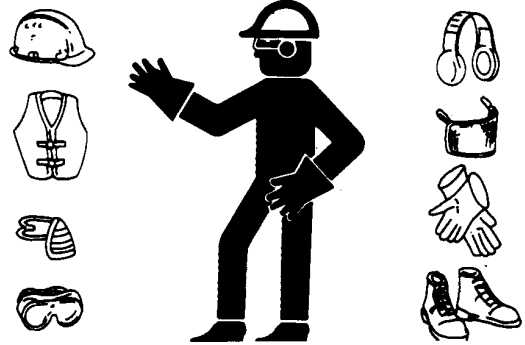

TS206—UN—15APR13

TX,WEAR,PE -19-22SEP10-1/1

Avoid Unauthorized Machine Modifications

John Deere recommends using only genuine John Deere replacement parts to ensure machine performance. Never substitute genuine John Deere parts with alternate parts not intended for the application as these can create hazardous situations or hazardous performance. Non-John Deere parts, or any damage or failures resulting from their use are not covered by any John Deere warranty.

Modifications of this machine, or addition of unapproved products or attachments, may affect machine stability or

reliability, and may create a hazard for the operator or others near the machine. The installer of any modification which may affect the electronic controls of this machine is responsible for establishing that the modification does not adversely affect the machine or its performance.

Always contact an authorized dealer before making machine modifications that change the intended use, weight or balance of the machine, or that alter machine controls, performance or reliability.

AM40430,00000A9 -19-20AUG09-1/1

Inspect Machine

Inspect machine carefully each day by walking around it before starting.

Keep all guards and shields in good condition and properly installed. Fix damage and replace worn or broken parts immediately. Pay special attention to hydraulic hoses and electrical wiring.



T6607AQ—UN—15APR13

TX,INSPECT -19-08SEP10-1/1

Stay Clear of Moving Parts

Entanglements in moving parts can cause serious injury.

Stop engine before examining, adjusting or maintaining any part of machine with moving parts.

Keep guards and shields in place. Replace any guard or shield that has been removed for access as soon as service or repair is complete.

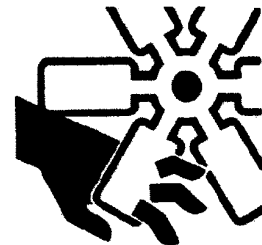

T133592—UN—15APR13

TX03679,00016D2 -19-03JAN07-1/1

Avoid High-Pressure Fluids

Inspect hydraulic hoses periodically – at least once per year – for leakage, kinking, cuts, cracks, abrasion, blisters, corrosion, exposed wire braid or any other signs of wear or damage.

Replace worn or damaged hose assemblies immediately with John Deere approved replacement parts.

Escaping fluid under pressure can penetrate the skin causing serious injury.

Avoid the hazard by relieving pressure before disconnecting hydraulic or other lines. Tighten all connections before applying pressure.

Search for leaks with a piece of cardboard. Protect hands and body from high-pressure fluids.

If an accident occurs, see a doctor immediately. Any fluid injected into the skin must be surgically removed within a few hours or gangrene may result. Doctors unfamiliar

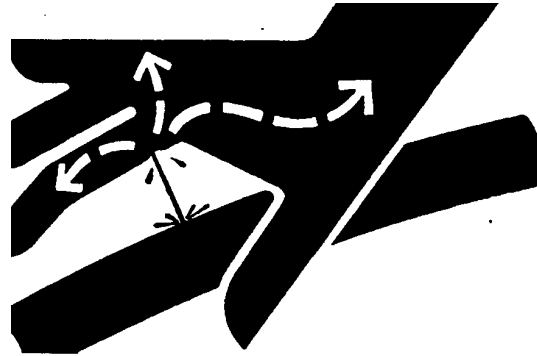

with this type of injury should reference a knowledgeable medical source. Such information is available in English from Deere & Company Medical Department in Moline, Illinois, U.S.A., by calling 1-800-822-8262 or +1 309-748-5636.

X9811 —UN—23AUG88

DX,FLUID -19-12OCT11-1/1

Avoid High-Pressure Oils

This machine uses a high-pressure hydraulic system. Escaping oil under pressure can penetrate the skin causing serious injury.

Never search for leaks with your hands. Protect hands. Use a piece of cardboard to find location of escaping oil. Stop engine and relieve pressure before disconnecting lines or working on hydraulic system.

If hydraulic oil penetrates your skin, see a doctor immediately. Injected oil must be removed surgically within hours or gangrene may result. Contact a knowledgeable medical source or the Deere & Company Medical Department in Moline, Illinois, U.S.A.

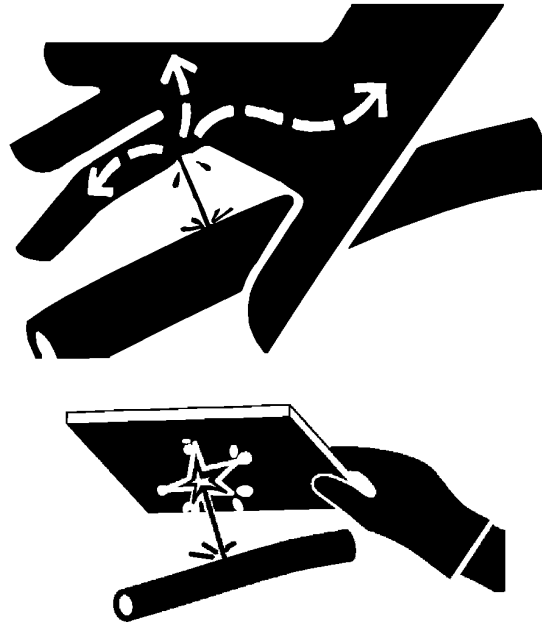

T133509 —UN—15APR13

T133840 —UN—20SEP00

TX03679.00016D3 -19-03NOV08-1/1

Work In Ventilated Area

Engine exhaust fumes can cause sickness or death. If it is necessary to run an engine in an enclosed area, remove the exhaust fumes from the area with an exhaust pipe extension.

If you do not have an exhaust pipe extension, open the doors and get outside air into the area.

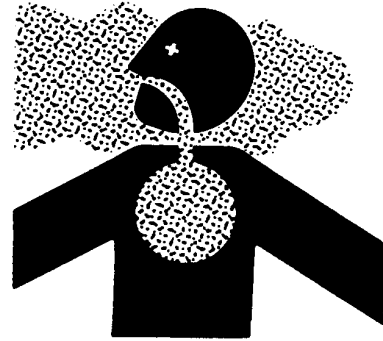

TS220 —UN—15APR13

DX,AIR -19-17FEB99-1/1

Prevent Fires

Handle Fuel Safely: Store flammable fluids away from fire hazards. Never refuel machine while smoking or when near sparks or flame.

Clean Machine Regularly: Keep trash, debris, grease and oil from accumulating in engine compartment, around fuel lines, hydraulic lines, exhaust components, and electrical wiring. Never store oily rags or flammable materials inside a machine compartment.

Maintain Hoses and Wiring: Replace hydraulic hoses immediately if they begin to leak, and clean up any oil spills. Examine electrical wiring and connectors frequently for damage.

Keep A Fire Extinguisher Available: Always keep a multipurpose fire extinguisher on or near the machine. Know how to use extinguisher properly.



T133553 —UN—07SEP00



T133554 —UN—07SEP00



TX03679,00016F5 -19-03NOV08-1/1

T133552 —UN—15APR13

Prevent Battery Explosions

Keep sparks, lighted matches, and open flame away from the top of battery. Battery gas can explode.

Never check battery charge by placing a metal object across the posts. Use a volt-meter or hydrometer.

Do not charge a frozen battery; it may explode. Warm battery to 16°C (60°F).



TS204—UN—15APR13

DX,SPARKS -19-03MAR93-1/1

Handle Chemical Products Safely

Direct exposure to hazardous chemicals can cause serious injury. Potentially hazardous chemicals used with John Deere equipment include such items as lubricants, coolants, paints, and adhesives.

A Material Safety Data Sheet (MSDS) provides specific details on chemical products: physical and health hazards, safety procedures, and emergency response techniques.

Check the MSDS before you start any job using a hazardous chemical. That way you will know exactly what the risks are and how to do the job safely. Then follow procedures and recommended equipment.

(See your John Deere dealer for MSDS's on chemical products used with John Deere equipment.)

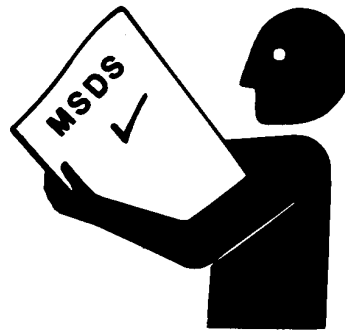

TS1132—UN—15APR13

DX,MSDS,NA -19-03MAR93-1/1

Dispose of Waste Properly

Improperly disposing of waste can threaten the environment and ecology. Potentially harmful waste used with John Deere equipment include such items as oil, fuel, coolant, brake fluid, filters, and batteries.

Use leakproof containers when draining fluids. Do not use food or beverage containers that may mislead someone into drinking from them.

Do not pour waste onto the ground, down a drain, or into any water source.

Air conditioning refrigerants escaping into the air can damage the Earth's atmosphere. Government regulations may require a certified air conditioning service center to recover and recycle used air conditioning refrigerants.

Inquire on the proper way to recycle or dispose of waste from your local environmental or recycling center, or from your John Deere dealer.

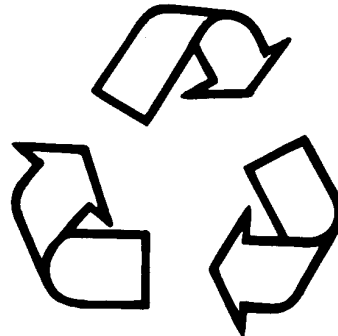

TS1133—UN—15APR13

DX,DRAIN -19-03MAR93-1/1

Prepare for Emergencies

Be prepared if a fire starts.

Keep a first aid kit and fire extinguisher handy.

Keep emergency numbers for doctors, ambulance service, hospital, and fire department near your telephone.

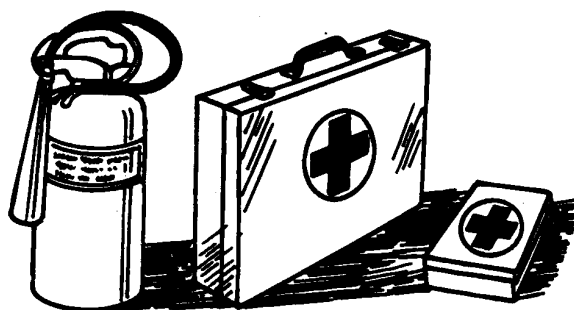

TS291—UN—15APR13

DX,FIRE2 -19-03MAR93-1/1

Clean Debris from Machine

Keep engine compartment, radiator, batteries, hydraulic lines, exhaust components, fuel tank, and operator's station clean and free of debris.

Clean any oil spills or fuel spills on machine surfaces.

Temperature in engine compartment may go up immediately after engine is stopped. **BE ON GUARD FOR FIRES DURING THIS PERIOD.**

Open access door(s) to cool the engine faster, and clean engine compartment.

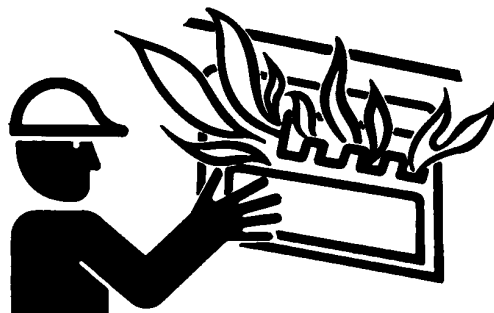

T6669AG—UN—15APR13

OUT4001,00000E3 -19-20AUG09-1/1

Safety—Operating Precautions

Use Steps and Handholds Correctly

Prevent falls by facing the machine when getting on and off. Maintain 3-point contact with steps and handrails. Never use machine controls as handholds.

Use extra care when mud, snow, or moisture present slippery conditions. Keep steps clean and free of grease or oil. Never jump when exiting machine. Never mount or dismount a moving machine.

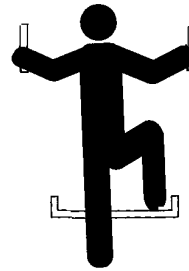

T133468 —UN—15APR13

TX03679,00016F2 -19-24APR13-1/1

Start Only From Operator's Seat

Avoid unexpected machine movement. Start engine only while sitting in operator's seat. Ensure all controls and working tools are in proper position for a parked machine.

Never attempt to start engine from the ground. Do not attempt to start engine by shorting across the starter solenoid terminals.



T133715 —UN—15APR13

TX03679,0001799 -19-22APR10-1/1

Use and Maintain Seat Belt

Use seat belt when operating machine. Remember to fasten seat belt when loading and unloading from trucks and during other uses.

Examine seat belt frequently. Be sure webbing is not cut or torn. Replace seat belt immediately if any part is damaged or does not function properly.

The complete seat belt assembly should be replaced every 3 years, regardless of appearance.



USE SEAT BELT

T133716 —19—17APR13

TX03679,00016DD -19-03NOV08-1/1

Prevent Unintended Machine Movement

Be careful not to accidentally actuate controls. Follow these steps during work interruptions, before allowing coworkers to approach the machine, before standing up, leaving the operator's seat, or exiting the machine:

- Lower equipment to the ground
- Press park brake switch (1) to position P to engage park brake
- Stop the engine
- Raise interlocking seat bar

1—Park Brake Switch



TX1064905A —UN—23SEP09

OUT4001,0000467 -19-28SEP09-1/1

Avoid Work Site Hazards

Avoid contact with gas lines, buried cables and water lines. Call utility line location services to identify all underground utilities before starting work.

Prepare work site properly. Avoid operating near structures or objects that could fall onto the machine. Clear away debris that could move unexpectedly if run over.

Avoid boom or attachment contact with overhead obstacles or overhead electrical lines. Never move machine closer than 3 m (10 ft) plus twice the line insulator length to overhead wires.

Keep bystanders clear at all times. Keep bystanders away from raised booms, attachments, and unsupported loads. Avoid swinging or raising booms, attachments, or loads over or near personnel. Use barricades or a signal person to keep vehicles and pedestrians away. Use a signal person if moving machine in congested areas or where visibility is restricted. Always keep signal person in view. Coordinate hand signals before starting machine.

Operate only on solid footing with strength sufficient to support machine. Be especially alert working near embankments or excavations.

Avoid working under over-hanging embankments or stockpiles that could collapse under or on machine.

Reduce machine speed when operating with tool on or near ground when obstacles may be hidden (e.g., during snow removal or clearing mud, dirt, etc.). At high speeds hitting obstacles (rocks, uneven concrete or manholes)

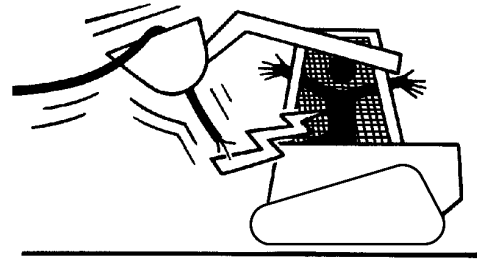

can cause a sudden stop. Always wear your seat belt. On units equipped with shoulder belts always wear both the seat and shoulder belt and **do not lean forward** while operating.

Do not stand on track.

OUT4001,00004A3 -19-23SEP09-1/1

T211519 —UN—02JUN05

TX1064890 —UN—02OCT09

Keep Riders Off Machine

Only allow operator on machine.

Riders are subject to injury. They may fall from machine, be caught between machine parts, or be struck by foreign objects.

Riders may obstruct operator's view or impair his ability to operate machine safely.

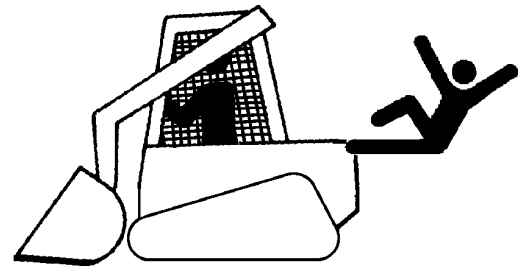

VD76477,0000045 -19-02JUN05-1/1

T211522 —UN—02JUN05

Avoid Backover Accidents

Before moving machine, be sure all persons or vehicles are clear of machine path. Turn around and look directly for best visibility. Keep windows clean.

Be certain reverse warning alarm is working properly (if equipped).

Use a signal person when backing if view is obstructed or when in close quarters. Keep signal person in view at all times. Use prearranged hand signals to communicate.



T211523—UN—02JUN05

VD76477,0000044 -19-02JUN05-1/1

Avoid Machine Tip Over

Use seat belt at all times.

Do not jump if the machine tips. You will be unlikely to jump clear and the machine may crush you.

Load and unload from trucks or trailers carefully. Be sure truck is wide enough and on a firm level surface. Use loading ramps and attach them properly to truck bed.

Be careful on slopes. Avoid sharp turns. Balance loads so weight is evenly distributed and load is stable. Carry tools and loads close to the ground to aid visibility and lower center of gravity. Use extra care on wet, soft, rocky, or frozen ground.

Know the capacity of the machine. Do not overload. Be careful with heavy loads. Using oversize buckets or lifting heavy objects reduces machine stability.

Ensure solid footing. Use extra care in soft ground conditions or on structures that may not uniformly support the tracks especially when raising the boom. Do not operate close to banks or open excavations that may cave in and cause machine to tip or fall.



**USE
SEAT
BELT**

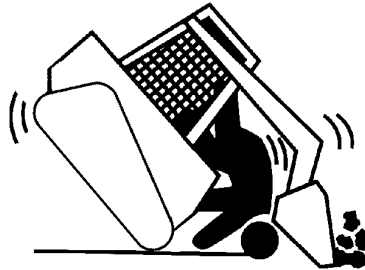

T133716—19—17APR13

T211525—UN—02JUN05

VD76477,0000046 -19-10APR07-1/1

Operating On Slopes

Avoid side slope travel whenever possible. When working on steep slopes, travel as straight up and down as possible and keep the heavy end of the vehicle uphill to prevent machine tip over.

Carry the load as low as possible for maximum stability and visibility.

Select low speed before starting down slope. The slope on which you can operate safely will be limited by ground condition and the load being handled.

Be alert to wind direction and velocity.



TX1063678—UN—01SEP09

OUT4001,0000471 -19-28AUG09-1/1

Operating Or Traveling On Public Roads

Machines that work near vehicle traffic or travel slower than normal highway speeds must have proper lighting and markings to assure they are visible to other drivers.

Install additional lights, beacons, slow moving vehicle (SMV) emblems, or other devices and use as required to make the machine visible and identify it as a work machine. Check state and local regulations to assure compliance. Keep these devices clean and in working condition.

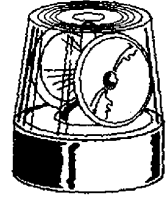
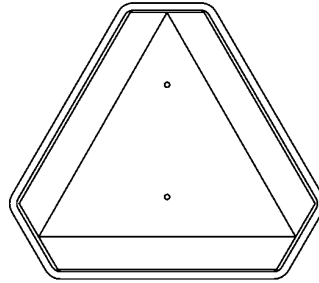

T141891 —UN—15APR13

TX03679,00017C8 -19-14JUN01-1/1

Inspect and Maintain ROPS

A damaged roll-over protective structure (ROPS) should be replaced, not reused.

The protection offered by ROPS will be impaired if ROPS is subjected to structural damage, is involved in an overturn incident, or is in any way altered by welding, bending, drilling, or cutting.

If ROPS was loosened or removed for any reason, inspect it carefully before operating the machine again.

To maintain the ROPS:

- Replace missing hardware using correct grade hardware.
- Check hardware torque.
- Check isolation mounts for damage, looseness or wear; replace them if necessary.
- Check ROPS for cracks or physical damage.

TX03679,000179F -19-20APR01-1/1

Add and Operate Attachments Safely

Always verify compatibility of attachments by contacting your authorized dealer. Adding unapproved attachments may affect machine stability or reliability, and may create a hazard for others near the machine.

Ensure that a qualified person is involved in attachment installation. Add guards to machine if operator protection

is required or recommended. Verify that all connections are secure and attachment responds properly to controls.

Carefully read attachment manual and follow all instructions and warnings. In an area free of bystanders and obstructions, carefully operate attachment to learn its characteristics and range of motion.

TX03679,00016F0 -19-24JAN07-1/1

Safety—Maintenance Precautions

Park and Prepare for Service Safely

Warn others of service work. Always park and prepare machine for service or repair properly.

- Park machine on a level surface and lower equipment to the ground.
- Engage park brake.
- Stop engine and remove key.
- Attach a “DO NOT OPERATE” tag in an obvious place in the operator’s station.

Securely support machine or attachment before working under it.

- Do not support machine with any hydraulically actuated tools or attachments.
- Do not support machine with cinder blocks or wooden pieces that may crumble or crush.
- Do not support machine with a single jack or other devices that may slip out of place.
- Always install boom lock before working on or around this machine with the loader boom raised.

Understand service procedures before beginning repairs. Keep service area clean and dry. Use two people whenever the engine must be running for service work.

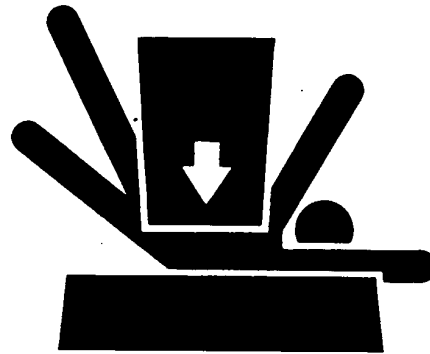

TX,PARK,SSL -19-28JUN10-1/1

T133332 —19—17APR13

TS229 —UN—23AUG88

Service Cooling System Safely

Explosive release of fluids from pressurized cooling system can cause serious burns.

Shut off engine. Only remove filler cap when cool enough to touch with bare hands. Slowly loosen cap to first stop to relieve pressure before removing completely.

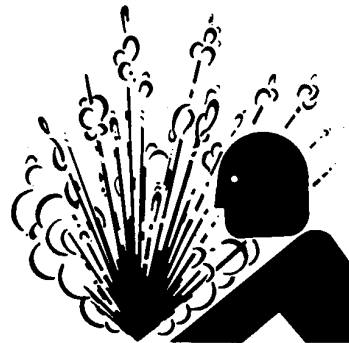

DX,RCAP -19-04JUN90-1/1

TS281 —UN—15APR13

Remove Paint Before Welding or Heating

Avoid potentially toxic fumes and dust.

Hazardous fumes can be generated when paint is heated by welding, soldering, or using a torch.

Remove paint before heating:

- Remove paint a minimum of 100 mm (4 in.) from area to be affected by heating. If paint cannot be removed, wear an approved respirator before heating or welding.
- If you sand or grind paint, avoid breathing the dust. Wear an approved respirator.
- If you use solvent or paint stripper, remove stripper with soap and water before welding. Remove solvent or paint stripper containers and other flammable material from area. Allow fumes to disperse at least 15 minutes before welding or heating.

Do not use a chlorinated solvent in areas where welding will take place.



Do all work in an area that is well ventilated to carry toxic fumes and dust away.

Dispose of paint and solvent properly.

DX,PAINT -19-24JUL02-1/1

TS220—UN—15APR13

Make Welding Repairs Safely

IMPORTANT: Disable electrical power before welding. Turn off main battery switch or disconnect positive battery cable. Separate harness connectors to engine and vehicle microprocessors.

Avoid welding or heating near pressurized fluid lines. Flammable spray may result and cause severe burns if pressurized lines fail as a result of heating. Do not let heat go beyond work area to nearby pressurized lines.

Remove paint properly. Do not inhale paint dust or fumes. Use a qualified welding technician for structural repairs.



Make sure there is good ventilation. Wear eye protection and protective equipment when welding.

TX03679,00016D5 -19-06FEB08-1/1

T133547—UN—15APR13

Drive Metal Pins Safely

Always wear protective goggles or safety glasses and other protective equipment before striking hardened parts. Hammering hardened metal parts such as pins and bucket teeth may dislodge chips at high velocity.

Use a soft hammer or a brass bar between hammer and object to prevent chipping.

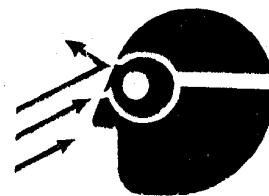

TX03679,0001745 -19-25SEP00-1/1

T133738—UN—15APR13

Handle Cab Door Safely

When servicing machine, be aware that cab door (1) is breakable.

Keep door closed if cab needs to be raised for service. Be aware of surroundings so that door does not come in contact with any objects.

Use care if cab door needs to be removed. To prevent damage to the door, handle with care and store in a secure location.

1— Cab Door



TX1063684A—UN—08SEP09

OUT4001,0000469 -19-28OCT09-1/1

Safety—Safety Signs

Replace Safety Signs

Replace missing or damaged safety signs. Use this operator's manual for correct safety sign placement.

There can be additional safety information contained on parts and components sourced from suppliers that is not reproduced in this operator's manual.



DX,SIGNS -19-18AUG09-1/1

TS201—UN—15APR13

Safety Signs

IMPORTANT
Operator's Manual

If manual is missing,
contact your
John Deere dealer.



CAUTION
Avoid Overturn
• Carry load low
• Avoid steep slopes and high speed
turns.
• Do not operate over rated capacity.

IMPORTANT
To prevent damage of hydraulics and engine, in
temperatures below 0°C (32°F), run at slow idle for
10 minutes before operation of controls.



CAUTION

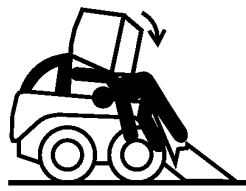

Read and understand Operator Manual before raising ROPS. Failure to do so may cause cab to fall, causing serious injury.

T265370

To maintain unimpaired operator protection and manufacturer's protective structure certification:
- Damaged Roll Over Protective Structures (ROPS) or Falling Object Protective Structures (FOPS) must be replaced, not repaired or revised.
- Any alteration to the ROPS or FOPS must be approved by the manufacturer.

PROTECTIVE STRUCTURE CERTIFICATION
Performance certified at date of manufacture to:
ROPS: OSHA: 1926.1061 FOPS: OSHA: 1926.1003
ISO: 3471: 2006 ISO: 3449 Level I 2005

ROPS certification weight: 6,804 Kg (15,000 LBS.)
John Deere 855D Steer Model: 315D, 316D, 320D, 323D,
326D, 328D, 329D, 332D, 333D

NOTE: Maximum machine weight can be found in the Operator's Manual.
Deere & Company
Moline, Illinois

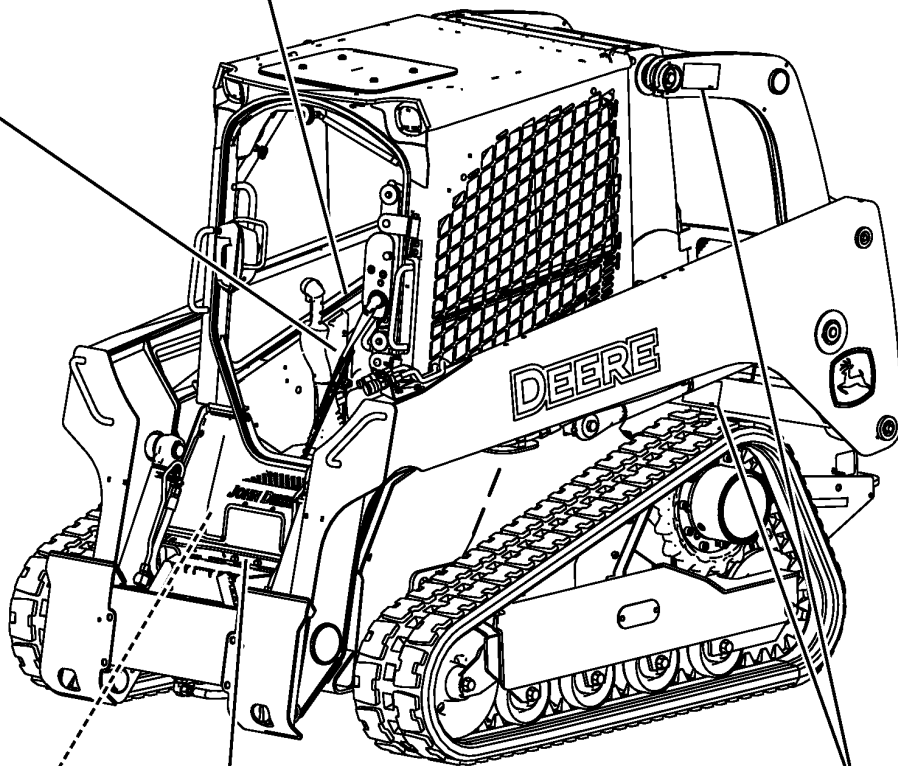

WARNING

Avoid injury from escaping fluid. Contents of this accumulator are under pressure.

1. Refer to proper Machine Model Technical Manual for removal and installation procedure.
2. This accumulator is charged with DRY NITROGEN by the manufacturer and is NOT rechargeable.

T243925

WARNING



**Pinch Area
Keep Away**

KV10695

WARNING



DANGER



WARNING



To prevent injury, lower lift arms fully before engaging or disengaging attachment engagement pins. Ensure the pins are fully engaged before operating loader.

KV23225

TX1063686

Continued on next page

OUT4001,0000473 -19-18SEP09-1/2

TX1063686 —19—02DEC09

⚠ DANGER



AVOID CRUSHING INJURY. Boom linkage moves near engine hood and frame. Never stand or lean anywhere on loader.

KV25397

⚠ WARNING



Always install boom lock before working on or around this machine with the loader boom raised. See Operator's Manual for complete instructions.

⚠ CAUTION

- AVOID BATTERY: Read and understand Operator's Manual before opening this machine.
- Know location and function of controls.
- Keep safety devices working.
- Keep screens and windows in place.
- Keep children and others away.
- Never carry riders.
- Lower boom, engage park brake, stop engine and remove key before leaving.
- Keep cab clean, especially pedal area.

⚠ WARNING



Avoid crushing injury. Boom linkage moves near engine hood and frame. Never stand or lean anywhere on loader.

KV25397

⚠ CAUTION

**PRESSURIZED
DO NOT OPEN HOT**

Remove Slowly
15 P.S.I.
AT17610

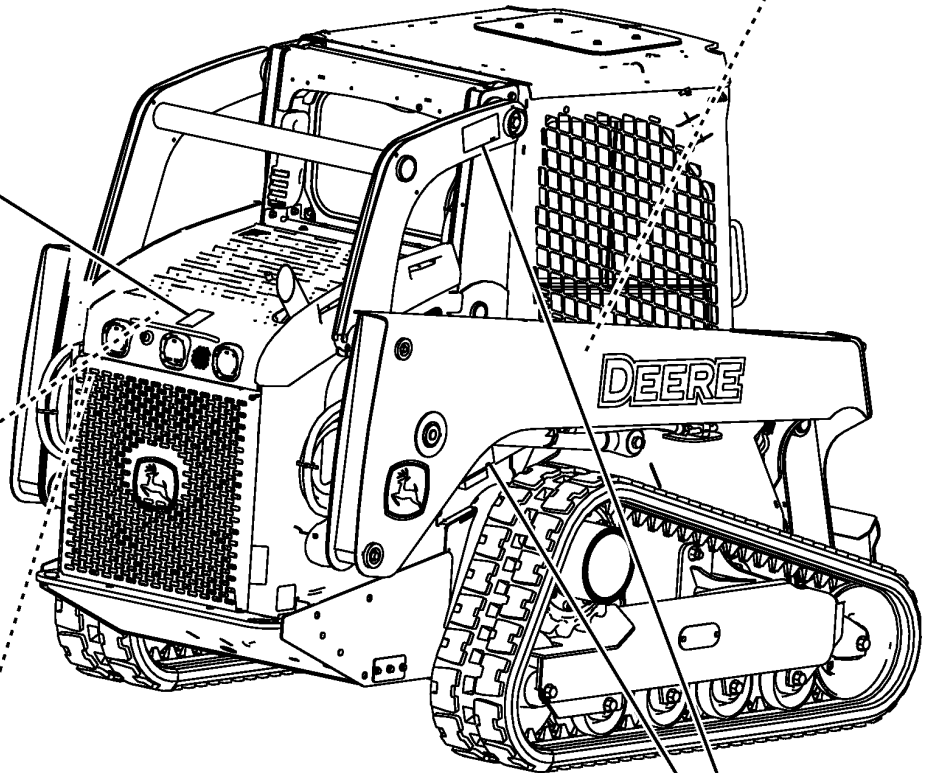

⚠ WARNING



Avoid rotating fan. Stop engine. Keep clear to avoid serious injury.

T187757

⚠ WARNING



**Pinch Area
Keep Away**

KV10895

TX1063685

OUT4001,0000473 -19-18SEP09-2/2

TX1063685 — 19—02DEC09

Operation—Operator's Station

Machine Control

Loader and steering control methods will vary on machine depending on what is ordered directly from factory. There are four machine configurations available:

- Manual—Hands Only Control
- Manual—Hand and Foot Control
- Electrohydraulic (EH) Control
- Electrohydraulic (EH) Control With Performance Package

For more detailed information, see Operation—Operating the Machine. (Section 2-2.)

Manual Controls—Choice of two options:

- Hands Only—Control levers (1 and 2) operate loader boom, bucket, and auxiliary hydraulic functions. Control levers also steer machine. Engine speed is controlled by either the engine speed control pedal (15) or the engine speed control dial (12).
- Hand and Foot—Foot pedals (13 and 14) operate loader boom and bucket functions. Control levers steer machine and operate auxiliary hydraulic functions. Engine speed is controlled by the engine speed control dial.

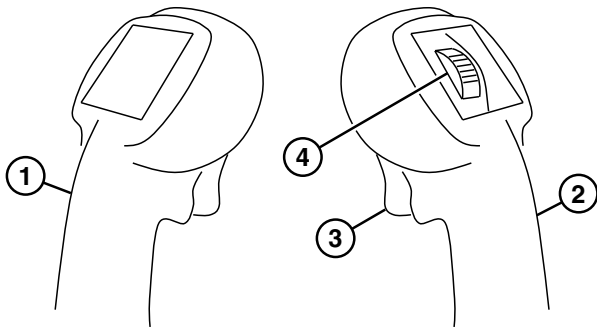

TX1066657 —UN—22OCT09

Manual Machine Without Horn or Two Speed Option

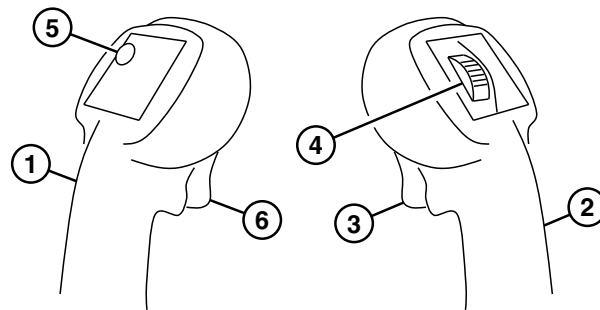

TX1066658 —UN—22OCT09

Manual Machine With Horn and Two Speed Option

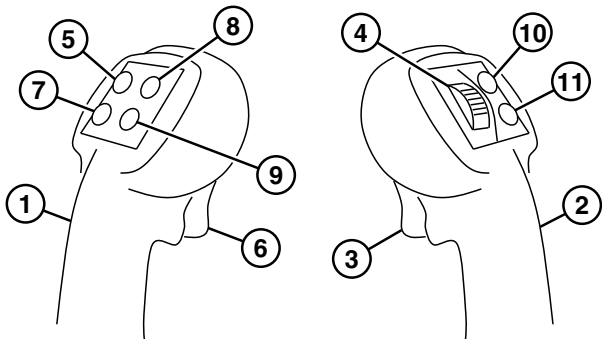

TX1066659 —UN—22OCT09

Manual Machine With Attachment Controls



TX1066701A —UN—22OCT09

Engine Speed Control Dial

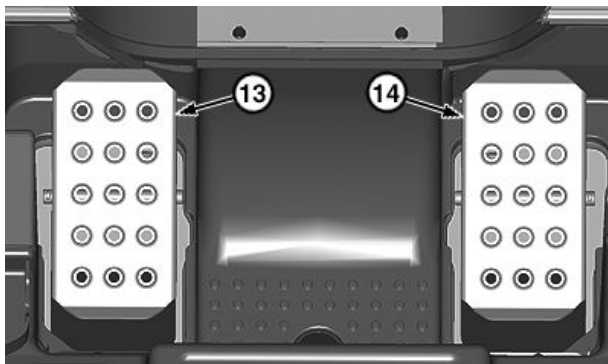

TX1066696A —UN—23OCT09

Foot Pedals—Hand and Foot Machine Only

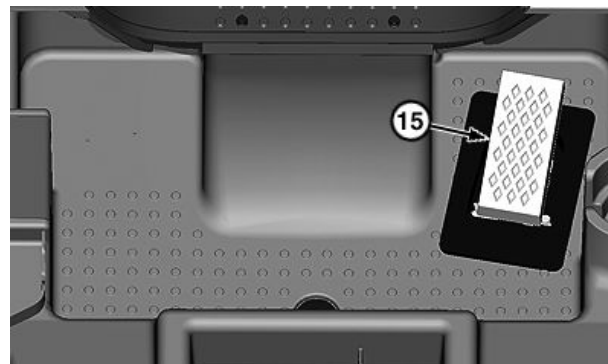

TX1066697A —UN—23OCT09

Engine Speed Control Pedal—Hands Only Machine

Continued on next page

OUT4001.000046D -19-11APR11-1/3

Operation—Operator's Station

- | | | |
|---|---|---|
| <p>1— Left Control Lever
 2— Right Control Lever
 3— Auxiliary Flow Set Switch
 4— Auxiliary Proportional Switch
 5— Horn—if equipped</p> | <p>6— Two Speed Switch—if equipped
 7— Not Used
 8— Auxiliary Third Function A Switch—if equipped
 9— Auxiliary Third Function B Switch—if equipped</p> | <p>10— Auxiliary Second Function A Switch—if equipped
 11— Auxiliary Second Function B Switch—if equipped
 12— Engine Speed Control Dial
 13— Left Foot Pedal
 14— Right Foot Pedal
 15— Engine Speed Control Pedal</p> |
|---|---|---|

OUT4001,000046D -19-11APR11-2/3

EH Controls—Choice of two different options:

- EH—Joysticks (1 and 2) operate loader boom, bucket, and auxiliary hydraulic functions. Joysticks also steer machine using an ISO pattern. Engine speed is controlled by either the engine speed control pedal (15) or the engine speed control dial (12).
- EH With Performance Package—Joysticks operate loader boom, bucket, and auxiliary hydraulic functions. Joysticks also steer machine. A pattern select switch (13) allows for quick change of joystick functions between ISO or H control patterns. Engine speed is controlled by either the engine speed control pedal or the engine speed control dial.

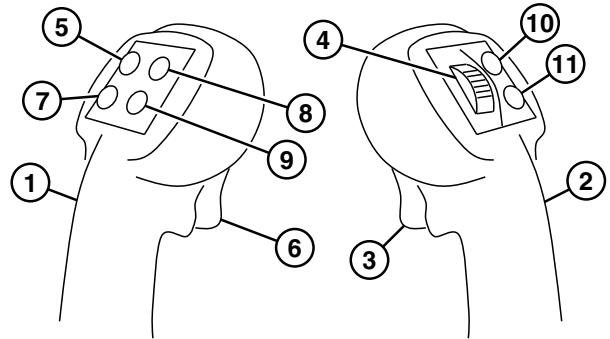

TX1066656—UN—22OCT09

- | | |
|---|---|
| <p>1— Left Joystick
 2— Right Joystick
 3— Float Switch
 4— Auxiliary Proportional Switch
 5— Horn—if equipped
 6— Two Speed Switch—if equipped
 7— Auxiliary Flow Set Switch</p> | <p>8— Auxiliary Third Function A Switch
 9— Auxiliary Third Function B Switch
 10— Auxiliary Second Function A Switch
 11— Auxiliary Second Function B Switch
 12— Engine Speed Control Dial
 13— Pattern Select Switch—if equipped
 15— Engine Speed Control Pedal</p> |
|---|---|



EH Machine
 Engine Speed Control Dial and Pattern Select Switch

TX1066655A—UN—22OCT09

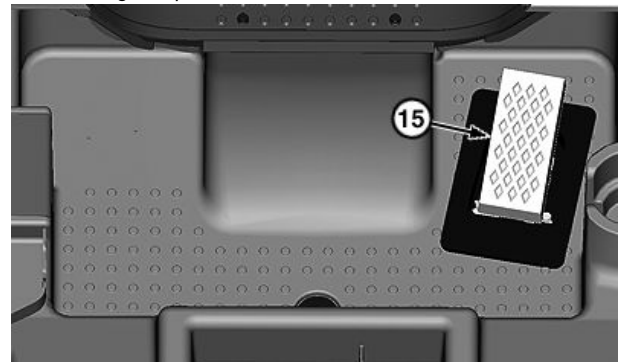

Engine Speed Control Pedal

TX1066657A—UN—23OCT09

OUT4001,000046D -19-11APR11-3/3

Control Panel

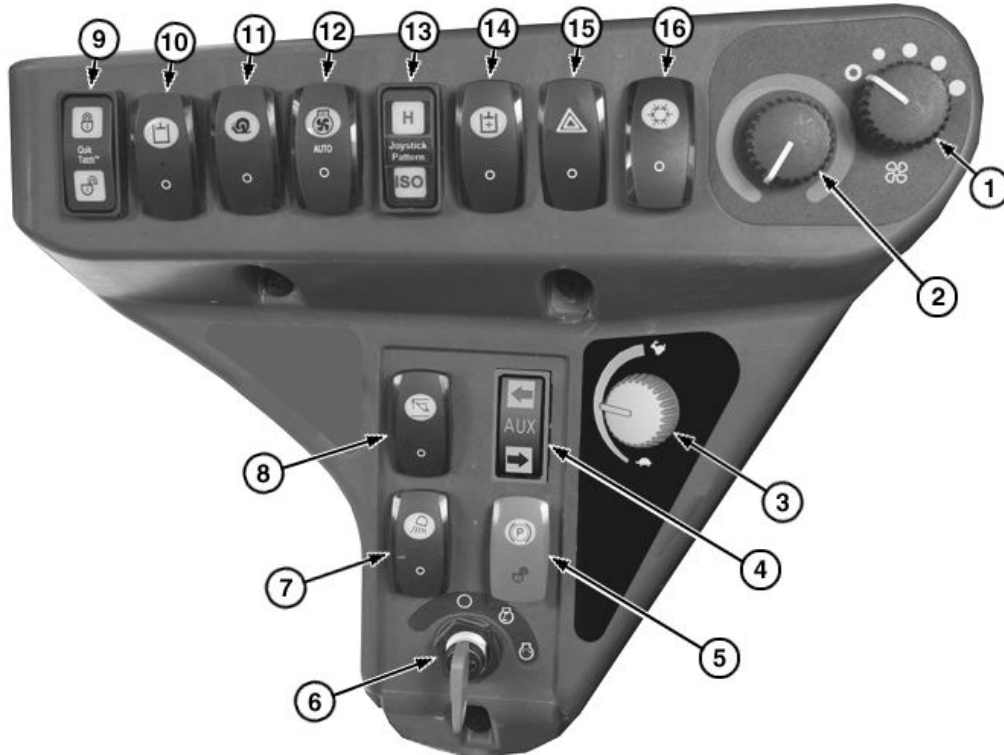

Control Panel

- | | | | |
|--|--------------------------------------|--|---|
| 1—Blower Speed Dial (if equipped) | 5—Park Brake Switch | 10—Auxiliary Hydraulic Override Switch | 14—High Flow Switch (if equipped) |
| 2—Cab Temperature Control Dial (if equipped) | 6—Key Switch | 11—Creep Mode Switch (if equipped) | 15—Dual Flasher Switch (if equipped) |
| 3—Engine Speed Control Dial | 7—Work Lights Switch | 12—Reversing Fan Switch (if equipped) | 16—Air Conditioner Switch (if equipped) |
| 4—Auxiliary Fourth Function Switch (if equipped) | 8—Self Leveling Switch (if equipped) | 13—Pattern Select Switch (if equipped) | |
| 9—Quik-Tatch™ Switch (if equipped) | | | |

Quik-Tatch is a trademark of Deere & Company

OUT4001,000046B -19-30JAN13-1/1

TX1063393A—UN—31AUG09

Control Panel Functions

1—Blower Speed Dial—If Equipped: Turn dial clockwise to increase blower speed. Blower has four speed settings plus an OFF position.

2—Cab Temperature Control Dial—If Equipped: Turn dial clockwise towards red zone for warmer air. Turn dial counterclockwise towards blue zone for cooler air.

3—Engine Speed Control Dial: Turn dial clockwise towards the rabbit to increase engine speed. Turn dial counterclockwise towards the turtle to decrease engine speed.

NOTE: The engine control unit (ECU) will default engine speed to slow idle on engine startup regardless of engine speed control dial position. Move engine speed control dial to slow idle position and then increase the setting to the desired speed to get the engine speed to increase.

4—Auxiliary Fourth Function Switch—If Equipped: Electric control of an auxiliary function.

5—Park Brake Switch: This switch has three positions:

- Push upper half of switch to engage park brake. This position also hydraulically locks the boom and bucket.
- Push to middle position to hydraulically enable boom and bucket while park brake is engaged.

NOTE: Operator must be in seat with seat belt fastened, with interlocking seat bar lowered, and engine must be running to disengage park brake.

- Push lower half of switch to momentary position and release to middle position to disengage park brake.

6—Key Switch: This switch has three positions:

- Position where ignition key can be inserted or removed is the OFF position. No circuits are active in this position.
- Turn key **clockwise** from the OFF position. This is the RUN position for the engine.
- Turn key **clockwise** from the RUN position. This is the START position for the engine. After starting engine, release key. Key will return to RUN position.

7—Work Lights Switch: This switch has three positions:

- Push upper half of switch to turn on front work lights, red tail lights, and rear work light.
- Push to middle position to turn on front work lights and red tail lights.
- Push lower half of switch to turn lights off.

8—Self Leveling Switch—If Equipped: Push upper half of switch to allow the attachment to remain in same relative position, as the boom is raised. Push lower half of switch to turn off this feature.

NOTE: Self leveling is only operational during boom raise function.

9—Quik-Tatch™ Switch—If Equipped: Press and hold upper half of switch until lock pins are engaged. Press and hold lower half of switch until lock pins are retracted.

NOTE: The switch will automatically return to center position when released. The mounting plates will stop at the position they are in at the time the switch is released.

10—Auxiliary Hydraulic Override Switch: Allows auxiliary hydraulics to operate after operator exits machine. This switch has two positions:

- Push upper half of switch to momentary position to activate bypass mode. Switch will return to lower position when released.

11—Creep Mode Switch—If Equipped: If machine is equipped with an EH performance package, push upper half of switch to activate creep mode. Creep mode limits travel speed while maintaining engine speed. Engagement and monitor unit (EMU) displays prompts for selecting desired percentage.

12—Reversing Fan Switch—If Equipped: Used to reverse the direction of fan rotation for purging debris from the radiator. This switch has three positions:

- Off—Disables reversing fan function.
- Auto (middle position)—Reverses fan every 20 minutes for 43 seconds. This position is used to prevent machine from overheating caused by accumulated debris against cooling package. Hydraulic oil temperature must be above 12°C (54°F).
- Manual—Press and hold switch in this position to manually activate reversing fan for 10 seconds. The switch can be used at any rpm. Hydraulic oil temperature must be above 12°C (54°F). Switch is programmed to wait 60 seconds before allowing fan to reverse cycle again.

13—Pattern Select Switch—If Equipped: If machine is equipped with an EH performance package, this switch allows for quick change of joystick functions between ISO or H control patterns. Push upper half of switch for H control pattern. Push lower half of switch for ISO control pattern.

14—High Flow Switch—If Equipped: Used for attachments that require a high hydraulic flow rate to operate. Push upper half of switch momentarily to turn ON and activate high flow option. Amber hydraulic high flow icon will appear on EMU. Push upper half of switch again to turn high flow option OFF.

15—Dual Flasher Switch—If Equipped: Push upper half of switch to turn warning lights on. Push lower half of switch to turn warning lights off.

16—Air Conditioner Switch—If Equipped: Push upper half of switch to turn on air conditioning. Push lower half of switch to turn off air conditioning.

NOTE: If equipped with water-in-fuel (WIF) indicator, indicator will replace creep mode switch on control panel.

17—Water-in-Fuel (WIF) Indicator—If Equipped (17): Indicator will light, STOP indicator will light, and audible alarm will sound when water is detected in the fuel system. Stop engine immediately.

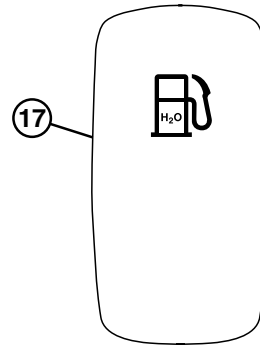

Water-in-Fuel (WIF) Indicator

**17— Water-in-Fuel (WIF)
Indicator (if equipped)**

Continued on next page

OUT4001,000046C -19-04FEB13-2/3

TX1130128A —UN—30JAN13

Engagement and Monitor Unit Operation

The engagement and monitor unit (EMU) can be used to display vital operating information, hours, diagnostic trouble codes, diagnostics, and to configure units of measure. It can also be used to lock the machine using an anti-theft security system. When the EMU powers up, the display initially reads "TMC by John Deere" for 1.5 seconds before showing the machine model and speeds for 3 seconds. If the anti-theft system has not been enabled or is not active, the display will default to the run-time screen. If the anti-theft system is enabled and unlocked, the display will default to the run-time screen. If the anti-theft system is enabled on the machine, the user will be prompted to enter their code. See Anti-Theft Security System in this section for more information.

Run Data Items

The Run Data Items are the default display when the EMU is powered up. The Run Data Items may also be displayed by cycling through the menu items by pressing the NEXT button, or by pressing MENU button at any time while in a submenu. Pressing SELECT button while viewing a Run Data Item will scroll through all the Run Data Items:

- Hours
- Volts
- Job Timer
- Hydraulic Oil Temperature
- Engine Coolant Temperature
- Engine RPM

If "CHECK SERVICE CODES" appears in the EMU display, press SELECT button to return to the Run Data Items. "CHECK SERVICE CODES" will appear for any hydraulic, park brake, or auto shutdown diagnostic trouble codes. If possible, move machine to a safe location before checking the diagnostic trouble codes. See Reading Diagnostic Trouble Codes in this section.

If MENU button is pressed during the run-time display, screen will advance to Main Menu. At any other time, the MENU button will go to last-selected run-time screen. If BACK button is pressed during the run-time display, screen will return to the previous run-time screen. At any other time, pressing BACK button will return to previous display screen. If NEXT button is pressed during the run-time display, screen will advance to the next run-time screen. At any other time, pressing NEXT button will scroll through menu items. If SELECT button is pressed during the run-time display, screen will advance to the next run-time screen. At any other time, pressing SELECT button will advance to next display screen.

• Boom and Bucket Rate Menu—if equipped

The Boom and Bucket Rate Menu allows the operator to select one of three boom and bucket speed rate settings. For more information, see Boom and Bucket Speed Settings—If Equipped. (Section 2-2.)

• Creep Limit Menu—if equipped

The Creep Limit Menu allows operator to set creep speed limit when equipped and engaged. For more

information, see Creep Mode Operation—If Equipped. (Section 2-2.)

• Codes Menu

The Codes Menu displays any diagnostic trouble codes (DTCs) that may be present in the machine. The Codes Menu displays both machine and engine DTCs. For more information, see Reading Diagnostic Trouble Codes in this section.

• Monitor Menu

The Monitor Menu allows operator to choose language and units format for their monitor.

• Job Timer Menu

The Job Timer Menu is a hour meter that can be reset. To reset Job Timer:

- Press SELECT button at Job Timer menu.
- Press SELECT button at Reset Time.

• Auto Idle Menu

The Auto Idle Menu allows the operator to enable or disable auto idle feature. For more information, see Auto Idle Operation. (Section 2-2.)

• Anti-Theft Menu—if equipped

See Anti-Theft Security System Operation in this section, for further information.

Anti-Theft Security System

The optionally-enabled anti-theft security system within the EMU provides a basic level of machine theft protection. When the anti-theft security system is enabled, the machine can be unlocked and locked with the use of either a 3-digit or 5-digit security code (depending on how the system is configured.) This security code, along with the machine key switch, is necessary to start and run the engine. When locked, the anti-theft security system prevents the engine from starting by disabling the fuel shutoff solenoid (Y1).

There are three levels of security within the anti-theft security system: Operator, Owner, and Master. The Operator level of security provides three different security codes that can be used by machine operators. The Owner level of security is designed for the owner or equipment manager. This security level is primarily to be used as a safeguard in the event an Operator code is forgotten or unknown, and the owner wishes to change or replace that security code.

After entering a valid Owner security code, the owner can:

- Lock and unlock the machine.
- Change the Owner security code.
- Change/reset an Operator security code.
- Enable/disable the auto lock feature.

The Master level of security is the highest security level and is used to enable or disable the anti-theft security system. A Master security code can be obtained for a machine by an owner by contacting their John Deere dealer. The dealer will need the current engine hour meter reading and the machine's serial number to generate a new Master security code.

All security codes are three digit numbers that are entered using the MENU and SELECT buttons on the EMU. Unlock or lock prompts appear on the EMU display at machine power up or power down, respectively. If the anti-theft security system is not enabled on the machine, no prompts will appear.

See Anti-Theft Security System Operation in this section, for further information.

Auto Lock Feature

The auto lock feature, when enabled, automatically locks the machine 5 minutes or 60 minutes after the operator leaves the seat if the machine had been left unlocked when turning key switch to OFF position.

See Anti-Theft Security System Operation in this section, for further information.

OUT4001,0000503 -19-11APR11-2/2

Engagement and Monitor Unit Display Messages

The engagement and monitor unit (EMU) automatically displays a message for specific machine situations and certain diagnostic trouble codes (DTCs). Depending on machine situation or if a DTC is initially active, a message displays on the EMU until the situation changes, the DTC is resolved, or the operator presses any button on the EMU.

If multiple display messages are generated, the one with the highest EMU priority displays. Pressing any button on the EMU closes the displayed message, allowing the next message to display in order of EMU importance until all generated messages have been displayed.

Display Message	Message Trigger
A/C OFF	Air conditioning has shut off because engine temperature is greater than 108°C (226°F).
Auto Idle	Auto Idle is active.
Aux Hydraulic Bypass	Auxiliary hydraulics are in override mode.
Check Service Code	A DTC is active that should trigger the Check Service Code monitor message.
Door Open	Operator attempted to release park brake without door closed (cab machines). Operator attempted to move right joystick with door open and seat interlock OK (cab machines).
Enable Hydraulics	Operator attempted to move right joystick after engine startup and seat belt fastened, but before enabling hydraulics (using park brake switch).
Engine Air Filter Restriction	Engine air filter restriction warning indicator comes on and indicator not in bulb check.
Engine Oil Pressure Low	Engine oil pressure indicator light comes on after engine is running.
Engine Temperature High	Engine temperature goes to the red zone of gauge and the engine is running.
Fasten Seat Belt Lower Lapbar	Operator attempted to release park brake without fastening seat belt and lowering interlocking seat bar.
H Pattern Selected	Pattern select option installed. H pattern steering and bucket control is active.
High Voltage	Battery voltage warning indicator comes on after engine is running and DTC is triggered.
Hyd. Oil Filter Restriction	Hydraulic oil filter restriction warning indicator comes on and indicator not in bulb check.
Hydraulic Oil Temp. High	Hydraulic oil temperature indicator light comes on and indicator not in bulb check.
ISO Pattern Selected	Pattern select option installed. ISO pattern steering and bucket control is active.
Left Joystick Not in Center	Joystick is out of neutral when park brake has just been released.
Low Fuel	Fuel level low after engine is running.
Low Voltage	Battery voltage warning indicator comes on after engine is running and DTC is triggered.
Precision Rate Selected	Adjustable boom and bucket rate installed. Precision mode is active.
Production Rate Selected	Adjustable boom and bucket rate installed. Production mode is active.
Release Park Brake	Operator attempted to move left joystick after engine startup and seat belt fastened, but before releasing park brake (using park brake switch).
Remote Start Connected	Remote start box installed.
Return Joysticks To Center	Appears when creep mode switch or pattern select switch is cycled.
Right Joystick Not in Center	Joystick is out of neutral when hydraulics are enabled.
Set Park Brake To Start Engine	The seat switch is active, the key switch is ON, and the engine is not running. (Park brake switch must be ON to start engine.)
Utility Rate Selected	Adjustable boom and bucket rate installed. Utility mode is active.
Hydraulic Temperature Too Low For Shift	Hydraulic oil temperature is below specification for two speed shift to occur. (318D and 320D only.)

OUT4001,0000506 -19-23NOV10-1/1

Anti-Theft Security System Operation—If Equipped

IMPORTANT: When providing operator security codes to machine users, owners should not provide operators with the default codes. Instead, owners should first change the default operator security codes to other values before providing codes to machine users.

NOTE: On a locked machine, engine can be started but will shut down after 3 seconds.

Unlocking the Machine (Operator and Owner)

1. Sit in the operator's seat to power up the engagement and monitor unit (EMU).
2. Turn key switch to ON position.
3. The EMU displays "Enter Code 0 __" (3-digit system) or "Enter Code 0 ____" (5-digit system).
4. Enter the appropriate security code:
 - a. Press the NEXT button or the BACK button to change the number displayed in the active (flashing) field. The NEXT button increments the current digit; the BACK button decrements the current digit.
 - b. Press the SELECT button to accept the number displayed (flashing) in the active field and shift the active field to the next digit to the right.

NOTE: Pressing the SELECT button to accept the last digit (third digit or fifth digit depending on system configuration) processes the entered security code.

5. If a correct security code is entered, the monitor displays "AntiTheft Unlocked" for 2 seconds before the EMU returns to the normal run-time display.

If the security code was incorrect, the display shows "Invalid Code".

NOTE: The anti-theft security system allows three attempts to enter a valid security code before requiring the key switch to be turned OFF and ON to restart the process.

Locking the Machine (Operator and Owner)

There are three different locking methods available with the anti-theft security system:

- Prompt for Lock
- Auto Lock—5 Minutes
- Auto Lock—60 Minutes

NOTE: On a locked machine, engine can be started but will shut down after 3 seconds.

Prompt for Lock

1. Turn key switch to OFF.

2. The monitor display shows "Press Select to Lock ATS."

NOTE: If you do not press SELECT to lock the machine within 20 seconds of turning key switch OFF, the EMU will NOT lock the machine.

3. Press the SELECT button within 20 seconds to lock the machine.

Auto Lock—5 Minutes

1. Turn key switch to OFF.
2. The monitor display shows "5 Min Auto Lock Lock Now?"
3. Machine remains unlocked for the next 5 minutes. After 5 minutes, a valid 3-digit or 5-digit security code, depending on system configuration is required for machine operation.

OR

Press SELECT to lock the machine immediately.

Auto Lock—60 Minutes

1. Turn key switch to OFF.
2. The monitor display shows "60 Min Auto Lock Lock Now?"
3. Machine remains unlocked for the next 60 minutes. After 60 minutes, a valid 3-digit or 5-digit security code, depending on system configuration is required for machine operation.

OR

Press SELECT to lock the machine immediately.

IMPORTANT: The default Owner security code for the anti-theft security system is 111 for 3-digit security systems and 00111 for 5-digit security systems. The default Operator security codes are 000, 999, and 998 for 3-digit security systems, and 00000, 00999, and 00998 for 5-digit security systems.

When providing Operator security codes to machine users, owners should not provide operators with the default codes. Instead, owners should first change the default Operator security codes to other values before providing codes to machine users.

Once the anti-theft security system has been enabled, either as a factory installed option or field installation, the system needs to be configured. Select the locking method and change the Owner and Operator security codes as necessary.

Selecting the Locking Method

Complete the following procedure to select the locking method for the anti-theft security system. Only someone with the Owner security code can configure the locking method. There are four locking options available within the anti-theft security system:

- Prompt for Lock—Machine will only be locked if selected during EMU shutdown.
 - Auto Lock, 5 Minutes—Machine is locked automatically 5 minutes after operator turns key switch to OFF position.
 - Auto Lock, 60 Minutes—Machine is locked automatically 60 minutes after operator turns key switch to OFF position.
 - Anti-Theft Off—Machine is not locked.
1. Press the MENU button on the EMU to access the Main Menu.
 2. Press the NEXT button until "Main Menu AntiTheft" displays.
 3. Press the SELECT button to display "AntiTheft Change Codes".
 4. Press the NEXT button to display "AntiTheft Lock Mode".
 5. Press the SELECT button to display "Enter Owner Code 0 __ _" (3-digit system) or "Owner Code 0 _ _ _ _" (5-digit system).
 6. Enter the current Owner security code.
The current locking method displays.
 7. Press the NEXT button to display the appropriate locking method:
 - Turn ATS Off
 - Prompt to Lock
 - Auto Lock in 5 Min
 - Auto Lock in 60 Min
 8. Press the SELECT button to select the displayed locking method.
 9. The selected locking method displays for 2 seconds before the EMU returns to the normal run-time display.

Changing an Operator or Owner Security Code

IMPORTANT: If you do not intend to use all three available Operator security codes, make sure you change the codes you will not be using to something other than their default values. Leaving access to the machine by means of default codes is not recommended.

The following rules apply when changing security codes:

- An Operator security code can only be changed if that security code or the Owner security code is used during the change procedure.

- The Owner security code can be used to reset all codes back to their defaults by accessing the RESET ALL CODES menu option.
- The anti-theft security system resets all Operator security codes and the Owner security code to the default values when the Master security code is used to enable the system.
- The Owner security code can only be changed by someone using the Owner security code. The Owner security code must be entered before changing that code.

1. Press the MENU button on the EMU to access the Main Menu.
2. Press the NEXT button until "Main Menu AntiTheft" displays.
3. Press the SELECT button to display "AntiTheft Change Codes".
4. Press the SELECT button. Display shows: "Change Codes Operator 1 Code".
5. If changing a different Operator security code or the Owner security code, press the NEXT button to display the appropriate security code to change. Proceed to next step.
6. Press the SELECT button. Display shows "Enter Current Code 0 _ _ _" (3-digit system) or "Enter Current Code 0 _ _ _ _" (5-digit system).
7. Enter the current Operator security code or Owner security code for the code to be changed.
 - a. Press the NEXT button or the BACK button to change the number displayed in the active (flashing) field. The NEXT button increments the current digit; the BACK button decrements the current digit.
 - b. Press the SELECT button to accept the number displayed (flashing) in the active field and shift the active field to the next digit to the right.

NOTE: Pressing the SELECT button to accept the last digit (third digit or fifth digit depending on system configuration) processes the entered security code. If the code is incorrect, an error message appears on the monitor display.

The anti-theft security system allows three attempts to enter a valid security code before requiring the key switch to be turned OFF and ON to restart the process.

8. Enter the new security code.
9. The new security code displays for 3 seconds before the EMU returns to the normal run-time display.

Resetting Operator and Owner Security Codes

1. Press the MENU button on the EMU to access the Main Menu.

2. Press the NEXT button until "Main Menu AntiTheft" displays.
3. Press the SELECT button to display "AntiTheft Change Codes".
4. Press the SELECT button. Display shows "Change Codes Operator 1 Code".
5. Press the NEXT button until "Change Codes Reset All Codes" displays.
6. Press the SELECT button. Display shows "Enter Owner Code 0 _ _" (3-digit system) or "Enter Owner Code 0 _ _ _ _" (5-digit system).
7. Enter the current Owner security code.
 - a. Press the NEXT button or the BACK button to change the number displayed in the active (flashing) field. The NEXT button increments the current digit; the BACK button decrements the current digit.
 - b. Press the SELECT button to accept the number displayed (flashing) in the active field and shift the active field to the next digit to the right.

NOTE: Pressing the SELECT button to accept the last digit (third digit or fifth digit depending on system configuration) processes the entered security code. If the code is incorrect, an error message appears on the monitor display.

The anti-theft security system allows three attempts to enter a valid security code before requiring the key switch to be turned OFF and ON to restart the process.

8. The anti-theft security system resets the Owner and three Operator security codes to their defaults of "111", "000", "999", and "998", respectively, for 3-digit security systems, and "00111", "00000", "00999", and "00998" for 5-digit security systems.
9. The default codes display before the EMU returns to the normal display mode menu.

NOTE: If the owner code is not available, security codes can be reset using the Master security code, which a John Deere dealer can obtain through DealerNet. Complete the anti-theft security system enable procedure to reset security codes using the Master security code.

Changing System Security Code Length

Use this procedure to select the length of security code to use with the anti-theft security system, either 3-digit or 5-digit. The system default is 3-digit.

1. Press the MENU button on the EMU to access the Main Menu.
2. Press the NEXT button until "Main Menu Antitheft" displays.
3. Press the SELECT button to display "AntiTheft Change Codes".
4. Press the NEXT button until "AntiTheft Number of Digits" displays.
5. Press the SELECT button. Display shows "Enter Owner Code 0 _ _" (3-digit system) or "Enter Owner Code 0 _ _ _ _" (5-digit system).
6. Enter the current Owner security code.
 - a. Press the NEXT button or the BACK button to change the number displayed in the active (flashing) field. The NEXT button increments the current digit; the BACK button decrements the current digit.
 - b. Press the SELECT button to accept the number displayed (flashing) in the active field and shift the active field to the next digit to the right.

NOTE: Pressing the SELECT button to accept the last digit (third digit or fifth digit depending on system configuration) processes the entered security code. If the code is incorrect, an error message appears on the monitor display.

The anti-theft security system allows three attempts to enter a valid security code before requiring the key switch to be turned OFF and ON to restart the process.

7. The current Antitheft System will be displayed, either "Select to Enable 3-Digit Codes" or "Select to Enable 5-Digit Codes." To change the selection, press the NEXT button to cycle between the different systems and then press the SELECT button to activate. At this point, all codes will be set to anti-theft system defaults, but the system locking method will remain unchanged.

OUT4001,0000504 -19-25MAR10-3/3

Reading Diagnostic Trouble Codes

Reading Diagnostic Trouble Codes (DTCs) on Engagement and Monitor Unit (EMU)

1. Turn machine key switch ON to power up all controllers in the system.
2. Wait several seconds until start up screens are done sequencing. Then press MENU button to go to the main menu screen.
3. Press the NEXT button until EMU displays MAIN MENU CODES. Press the SELECT button.
4. CODES ACTIVE displays.

- Press SELECT to view active DTCs, **OR**
- Press NEXT button to go to CODES STORED screen. Then press SELECT to view stored DTCs.

NOTE: If no DTCs are present, NO ACTIVE CODES or NO STORED CODES appears on the display.

5. To view active or stored DTC information:
 - Press the NEXT button to scroll through list of codes.
 - Press the SELECT button to view DTC details.
 - Press the BACK button to move up one menu level.

OUT4001.0000507 -19-23NOV09-1/1

Gauges and Indicator Lights

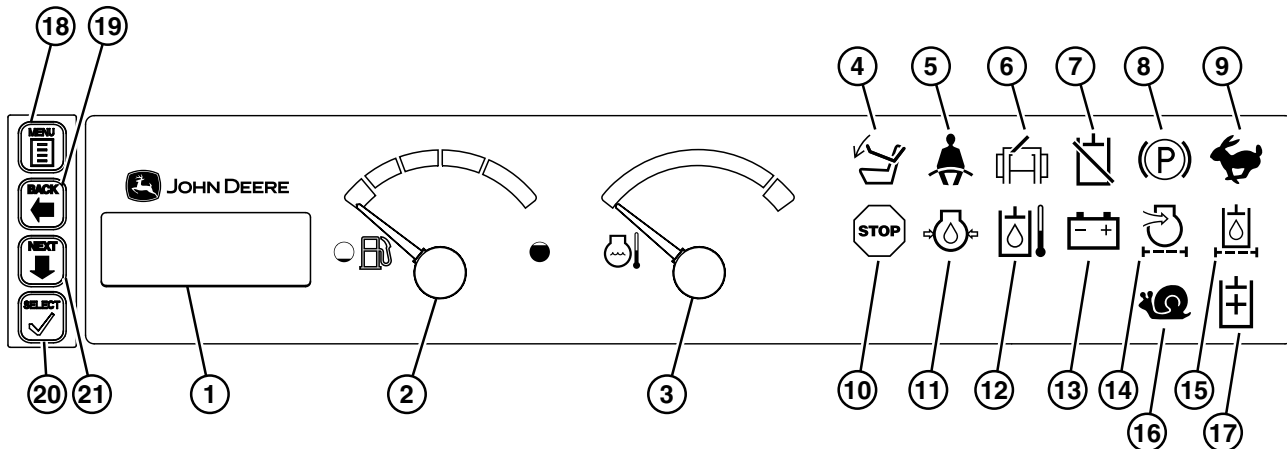

TX1066719 —UN—23OCT09

TX1066719

- | | | | |
|--|---------------------------------------|---|-----------------------------------|
| 1— Engagement and Monitor Unit (EMU) Display | 6— Cab Door Switch Indicator | 12— Hydraulic Oil Temperature Indicator | 16— Creep Mode Indicator |
| 2— Fuel Gauge | 7— Hydraulics OFF Indicator | 13— Low Alternator or Battery Voltage Indicator | 17— Hydraulic High Flow Indicator |
| 3— Engine Coolant Temperature Gauge | 8— Park Brake Indicator | 14— Engine Air Filter Restriction Indicator | 18— MENU Button |
| 4— Interlocking Seat Bar Switch Indicator | 9— Two Speed Indicator | 15— Hydraulic Oil Filter Restriction Indicator | 19— BACK Button |
| 5— Seat Belt Switch Indicator | 10— STOP Indicator | | 20— SELECT Button |
| | 11— Engine Low Oil Pressure Indicator | | 21— NEXT Button |

OUT4001.000050A -19-25AUG10-1/1

Gauge and Indicator Light Functions

1—Engagement and Monitor Unit (EMU) Display:

Displays vital operating information, hours, diagnostic trouble codes, diagnostics, and to configure units of measure.

2—Fuel Gauge: Indicates amount of fuel in fuel tank.

3—Engine Coolant Temperature Gauge: Indicates engine coolant temperature.

4—Interlocking Seat Bar Switch Indicator: Red indicator will light when interlocking seat bar is in the raised position.

5—Seat Belt Switch Indicator: Red indicator will light when interlocking seat bar is in the raised position and for 5 seconds after the interlocking seat bar is lowered to remind operator that seat belt is not fastened.

6—Cab Door Switch Indicator: Red indicator will light when cab door is open.

7—Hydraulics OFF Indicator: Red indicator will light when hydraulics are disabled.

8—Park Brake Indicator: Red indicator will light when park brake is engaged.

9—Two Speed Indicator: Amber indicator will light when two speed shift is in high range.

10—STOP Indicator: Red indicator will light when machine should be shut down.

11—Engine Low Oil Pressure Indicator: Red indicator will light when engine oil pressure is too low.

12—Hydraulic Oil Temperature Indicator: Red indicator will light when hydraulic oil temperature is too high.

13—Low Alternator or Battery Voltage Indicator: Amber indicator will light when alternator output is low or battery voltage is low.

14—Engine Air Filter Restriction Indicator: Amber indicator will light when air filter elements are restricted.

15—Hydraulic Oil Filter Restriction Indicator: Amber indicator will light when hydraulic filter element is restricted.

16—Creep Mode Indicator: Amber indicator will light when machine is in creep mode.

17—Hydraulic High Flow Indicator: Amber indicator will light when hydraulic high flow is activated.

18—MENU Button: Press button to scroll through menu options on the engagement and monitor unit.

19—BACK Button: Press button to return to previous menu options.

20—SELECT Button: Press button to select a menu or an item under a menu.

21—NEXT Button: Press button to move forward through menu options.

OUT4001,000050B -19-29OCT09-1/1

Auto Shutdown With Alarm

The machine is equipped with automatic shutdown to prevent machine damage.

- Engine coolant temperature gauge will indicate full hot, the alarm will sound, STOP indicator will flash, and the engagement and monitor unit (EMU) will shut the engine down after 5 seconds when engine coolant temperature is too high. The engine can be restarted and will run for 30 seconds before it will shut down again.
- Oil pressure indicator will light, the alarm will sound, STOP indicator will flash, and the EMU will shut the

engine down after 5 seconds when engine oil pressure is too low. The engine can be restarted and will run for 30 seconds before it will shut down again.

- Hydraulic oil temperature indicator will light, the alarm will sound, STOP indicator will flash, and the EMU will shut the engine down after 5 minutes when hydraulic oil temperature is too high. The engine can be restarted and will run for 30 seconds before it will shut down again.

OUT4001,000050C -19-28OCT09-1/1

Interlocking Seat Bar

Interlocking seat bar (1) must be lowered after sitting in the operator's seat in order for hydraulic and travel functions to operate.

Adjusting the Interlocking Seat Bar

1. Loosen lock nut (2) on right side of the interlocking seat bar.
2. Turn adjustable stop (3) clockwise to adjust seat bar lower. Turn adjustable stop counterclockwise to adjust seat bar higher.
3. Tighten lock nut when finished with adjustment.
4. Repeat procedure on left side of the interlocking seat bar to match.

1— Interlocking Seat Bar 3— Adjustable Stop
2— Lock Nut



Interlocking Seat Bar

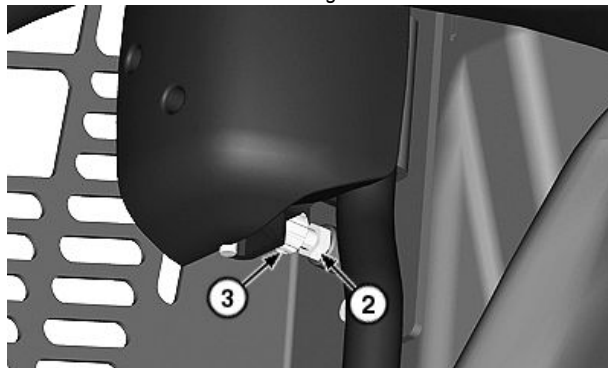

Locking Seat Bar Adjustment

TX1066761A —UN—23OCT09

TX1119802 —UN—07AUG12

OUT4001,000050D -19-27MAR13-1/1

Cab Door—If Equipped

If machine is equipped with a cab door, the cab door must be closed in order to enable boom and bucket functions.

Entering and Exiting the Cab

When entering the cab, pull handle (1) outward and open the door. Use handholds for assistance.

When exiting the cab, ensure engine is OFF and park brake is engaged. Raise interlocking seat bar. Hold on to bar (2) and push button (3) up with thumb or palm of hand. Swing door open and exit the cab safely using handholds.

1— Handle 3— Button
2— Bar

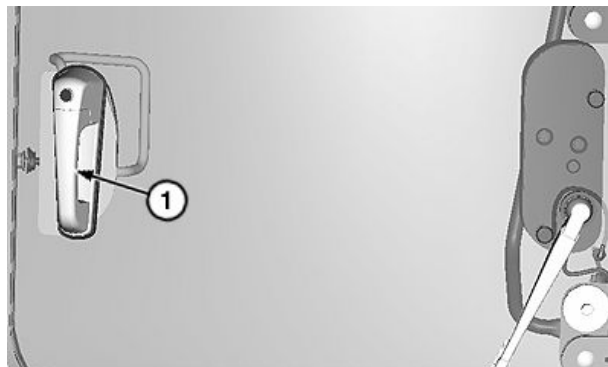

View Shown From Outside the Cab

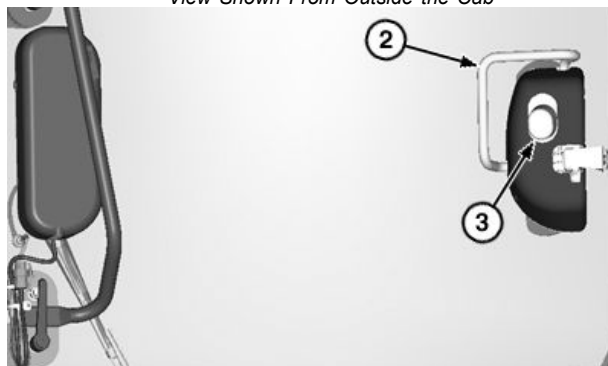

View Shown From Inside the Cab

TX1066866A —UN—27OCT09

TX1066865A —UN—27OCT09

Continued on next page

OUT4001,000050E -19-25MAR10-1/4

Removing and Installing Door

IMPORTANT: Handle door safely. When removing door, be aware that it is breakable.

To remove the door:

1. Park machine.
2. Raise boom and lock in raised position.
3. Engage park brake and turn engine OFF.
4. Remove the wire retainer (4) on gas shock rod (5) by rotating the wire retainer off of the shaft and pulling out. Remove gas shock rod from ball joint. Install wire retainer into shaft for storage.
5. Disconnect wiper motor harness connector (6).
6. Disconnect washer fluid line (7). Make sure to leave the check valve (8) connected to the fluid line inside the cab.
7. On outside of machine, remove cotter pin (9) and washer from top hinge pin. Store appropriately.
8. Open door until the stop (10) hits on door frame.
9. Using handles on inside of the door, carefully lift the door until the stop clears the door frame.

Specification

Door—Weight..... 22 kg
48 lb

10. Door can then be rotated further until the hinge and handhold do not contact.
11. Carefully lift door the rest of the way off and store in a protected area.

To install the door:

1. Park machine.
2. Raise boom and lock in raised position.
3. Engage park brake and turn engine OFF.
4. Carefully lift door. Start by having the door in the 180° open position from the front of the machine. Line up hinges with hinge pins and partially install. Slowly rotate door 90°, making sure to stay clear of handhold. Fully slide hinges down onto hinge pins.
5. Install cotter pin (9) and washer.

IMPORTANT: Wiper assembly must be connected so machine knows that a door is present. If the wiper assembly is not connected when a door is present, machine will allow the boom to function with the door in the open position which may result in damage to the door.

6. Connect washer fluid line (7) and wiper motor harness connector (6).
7. Remove wire retainer (4) from gas shock rod (5).

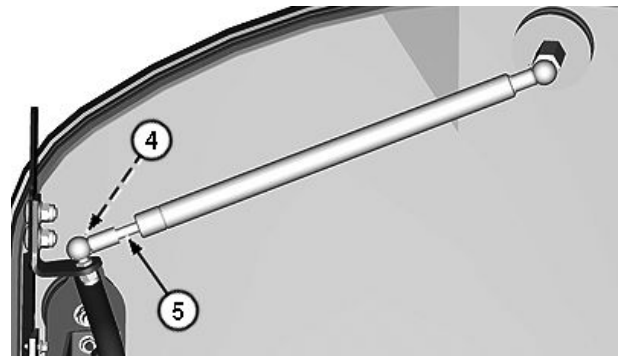

View Shown From Inside the Cab

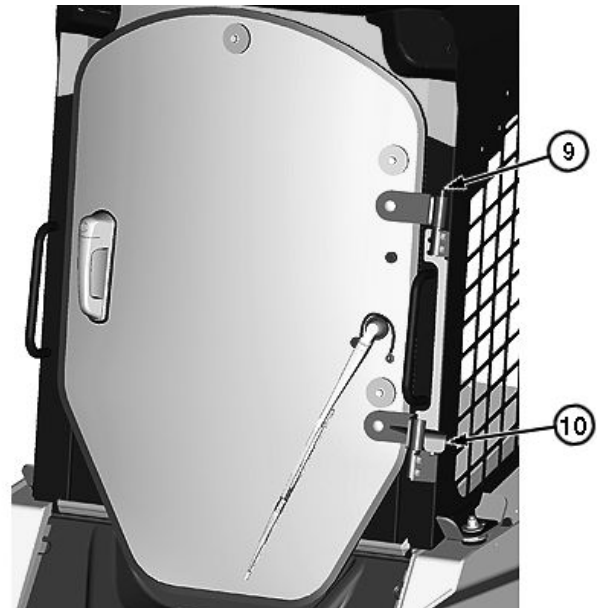

- 4— Wire Retainer
- 5— Gas Shock Rod
- 6— Wiper Motor Harness Connector
- 7— Washer Fluid Line
- 8— Check Valve
- 9— Cotter Pin
- 10— Stop

8. Install gas shock rod on ball joint. Install wire retainer.
9. Verify door seals and closes properly. If adjustment is needed, see following Door Adjustment story.

Continued on next page

OUT4001,000050E -19-25MAR10-2/4

TX1066868A—UN—12NOV09

TX1067684A—UN—12NOV09

TX1066919A—UN—12NOV09

Door Adjustment

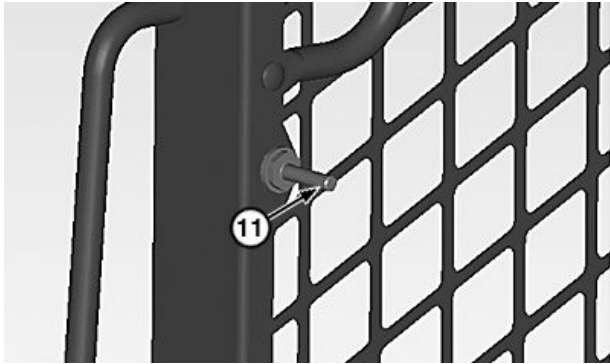

Striker Bolt

TX1074040A—UN—16MAR10



Hinge Fasteners

TX1074094A—UN—16MAR10

If door needs to be adjusted to seal properly, proceed with the following steps:

1. Position the striker bolt (11) toward the front, bottom of the mounting hole, and lightly tighten the nut. More adjustment may be required later.
2. Loosen the three hinge fasteners (12). Cycle the door open and close several times.

NOTE: The top hinge holes are slotted so door can move slightly to get the proper fit.

3. Slide the upper part of hinge (13) to the left or right so there is approximately 3 mm (1/8 in) gap between striker bolt and upper jaw of latch (14).
4. Lightly tighten the three hinge fasteners.
5. Latch door and verify that there is approximately 1 mm (1/32—1/16 in) of compression on door seal near the upper, latch-side corner of the door. If there is too much compression and door latches with difficulty (door will be harder to close when the side windows are closed), adjust the striker forward. If there is not enough compression, adjust the striker rearward. Try to keep the striker at a constant height to avoid needing to readjust the hinge to maintain striker-latch jaw clearance.
6. After a positive seal is achieved and the effort to close the door is acceptable, verify that the striker bolt/latch jaw clearance is still good. If not, readjust the hinge and/or striker bolt to correct the position of the striker bolt in the latch jaw.
7. Once all adjustments are complete, fully tighten the striker bolt and the three hinge fasteners.

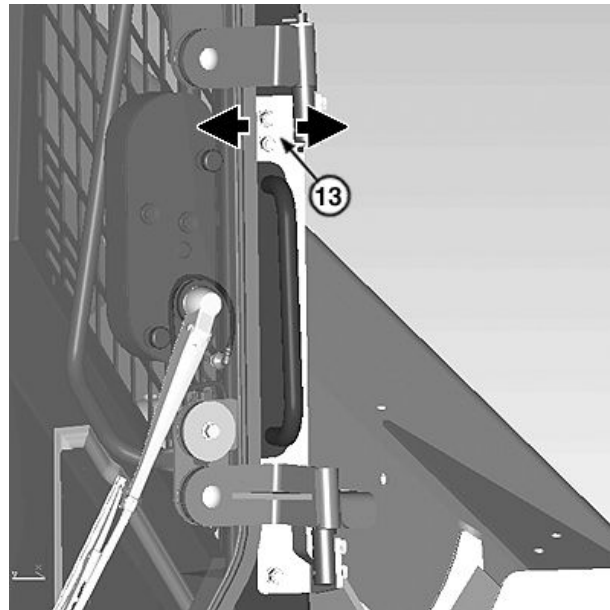

Upper Part of Hinge

TX1074095A—UN—16MAR10

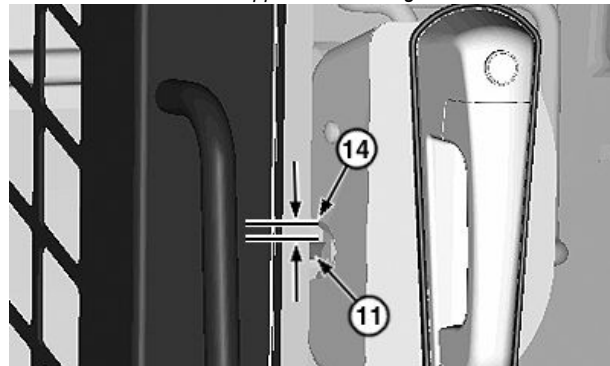

Door Latch

TX1074096A—UN—16MAR10

- | | |
|-----------------------------|-------------------------|
| 11— Striker Bolt | 13— Upper Part of Hinge |
| 12— Hinge Fastener (3 used) | 14— Upper Jaw of Latch |

Continued on next page

OUT4001,000050E -19-25MAR10-3/4

- From inside the cab with door closed and latched, adjust the door sensor bracket (15) so there is approximately 2 mm of space between the bracket and sensor (16). Less space is allowable, but the bracket should not touch the sensor. Fully tighten the bracket nuts when adjustment is complete.

15— Door Sensor Bracket 16— Sensor

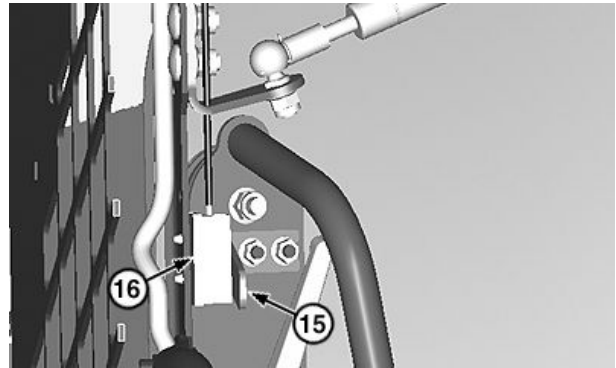

Door Sensor Bracket and Sensor

OUT4001,000050E -19-25MAR10-4/4

TX1074098A —UN—16MAR10

Opening Side Windows—If Equipped

To open side window, squeeze latch (1) and slide window rearward.

To close side window, slide window forward until latch clicks into place.

To remove side windows:

- Remove cap screws (2).
- Remove glass retainer (3).
- Slide back window section (4) forward to center of frame. Lift and pull bottom edge out towards operator. Remove back window section and place in a safe area.
- Slide front window section (5) back to center of frame. Lift and pull bottom edge out towards operator. Remove front window section.
- Store both sections in a protected area.

To install side windows:

- Install front window section first, lining up groove on bottom of window with the track in frame. Slide forward into stationary position.
- Install back window section, lining up groove on bottom of window with the inner track in frame. Slide rearward into stationary position.
- Install glass retainer.
- Install cap screws.

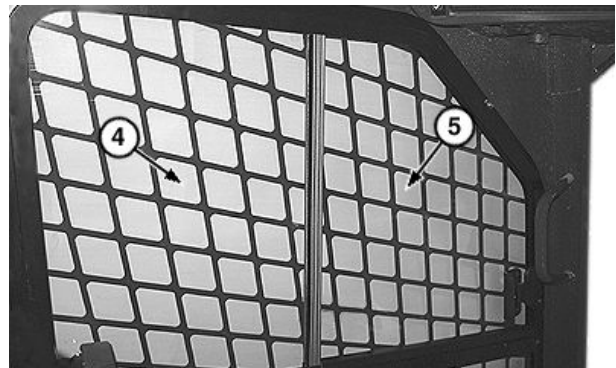
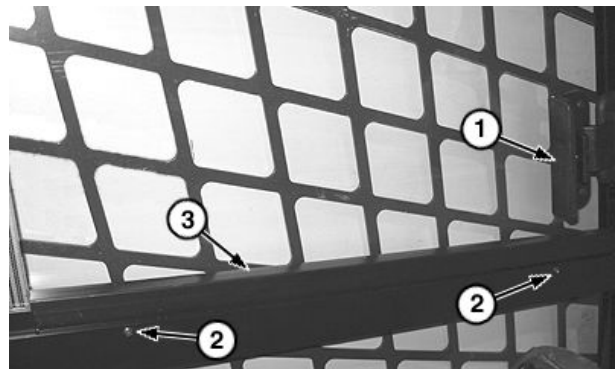

1— Latch
2— Cap Screw (2 used)
3— Glass Retainer

4— Back Window Section
5— Front Window Section

OUT4001,000050F -19-05NOV09-1/1

TX1066940A —UN—28OCT09

TX1066947A —UN—28OCT09

Top Window

Top window (1) is standard on cab or canopy.

Top window in cab is bolted in place and can be removed for cleaning. To remove top window:

- Remove four knobs (2) from inside the cab.
- Lift off window from outside the cab.
- Store window and hardware in a protected area.

Top window in canopy is permanently installed.

1— Top Window

2— Knob (4 used)

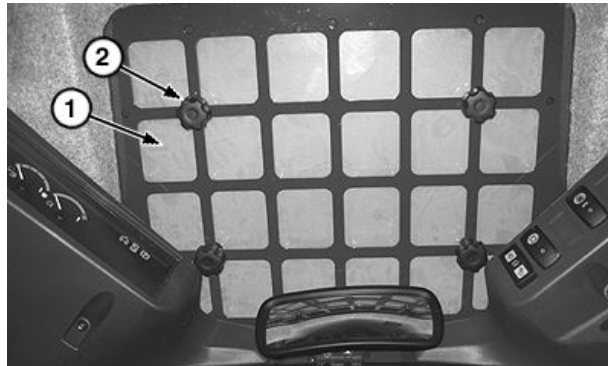

Top Window

TX1066928A—UN—28OCT09

OUT4001,0000514 -19-31OCT12-1/1

Rear Window (Secondary Exit)

Push on bottom corner (1) of window near the instruction label to force window out from molding.

1— Bottom Corner



Secondary Exit

TX1066770A—UN—23OCT09

OUT4001,0000513 -19-31OCT12-1/1

Fire Extinguisher Location

NOTE: All fire extinguishers do not operate the same. Read operating instructions on canister.

The portable fire extinguisher is used to aid in the extinguishing of small fires. Refer to individual manufacturers' instructions and proper fire fighting procedures before the need to use the fire extinguisher arises. For fire prevention safety rules, see Prevent Fires. (Section 1-2.)

IMPORTANT: Avoid possible machine damage. Replace or recharge fire extinguisher after every use according to the manufacturer's instructions.

The designated fire extinguisher location (1) is inside the cab on either side of the rear window. Check gauge (if equipped) on fire extinguisher. If fire extinguisher is not fully charged, recharge or replace it according to the manufacturer's instructions.



Fire Extinguisher Location

1— Fire Extinguisher Location

TX1082854A—UN—11OCT10

Inspect and maintain the fire extinguisher following the manufacturer's recommendations and all local, regional, and national regulations.

ER79617,0000C6B -19-27MAR13-1/1

12-Volt Power Outlet

NOTE: Machine switched power must be on for operation.

A 12-volt power outlet (1) is located in the upper left corner of the cab. Keep outlet free of dirt and moisture for uninterrupted operation.

- 1— 12-Volt Power Outlet
- 2— Service ADVISOR™ Connector

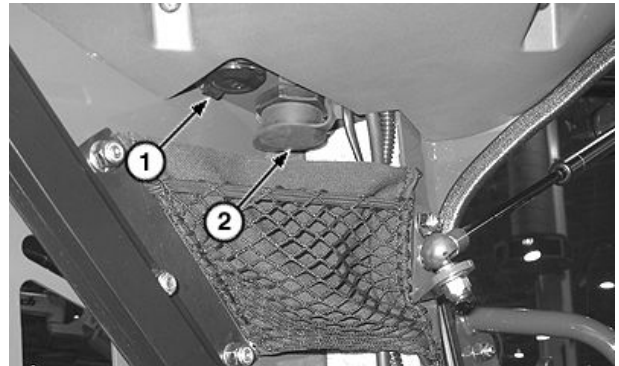

Power Outlet

Service ADVISOR is a trademark of Deere & Company

OUT4001,0000510 -19-27MAR13-1/1

TX1066774A —UN—11NOV09

Heating/Defrosting Controls—If Equipped

Turn blower speed dial (1) clockwise to turn heater/defroster ON and to increase blower speed. Blower has four speed settings plus an OFF position.

Turn cab temperature control dial (2) clockwise towards red zone for warmer air.

- 1— Blower Speed Dial
- 2— Cab Temperature Control Dial



OUT4001,0000511 -19-22OCT09-1/1

TX1066777A —UN—23OCT09

Air Conditioning Controls—If Equipped

Push upper half of air conditioner switch (1) to turn air conditioning on.

Turn cab temperature control dial (2) counterclockwise towards blue zone for cooler air.

Turn blower speed dial (3) clockwise to increase blower speed. Blower has four speed settings plus an OFF position.

- 1— Air Conditioner Switch
- 2— Cab Temperature Control Dial
- 3— Blower Speed Dial

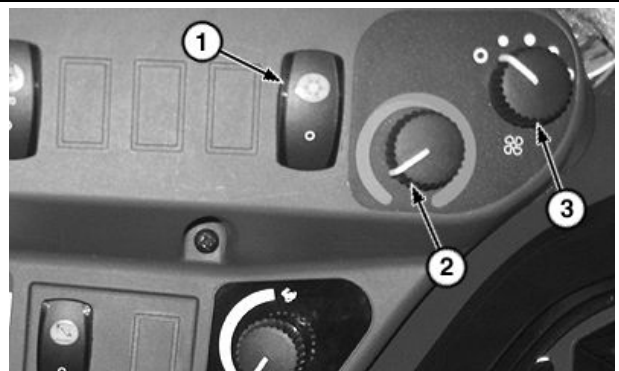

Air Conditioning Controls

OUT4001,0000512 -19-30OCT12-1/1

TX1066778A —UN—23OCT09

Seat Adjustment

Mechanical Suspension Seat (if equipped)

1. Rotate lever (1).
2. Slide seat forward or backward to desired position.
3. Release lever to lock in place.
4. Fold out handle (2) to adjust seat to weight of operator.
5. Turn handle clockwise for a heavier operator. Turn handle counterclockwise for a lighter operator.
6. Return handle to original position.

1—Lever

2—Handle



Vinyl Mechanical Suspension Seat

OUT4001.000051B -19-12NOV09-1/2

TX1066793A—UN—10NOV09

Air Suspension Seat (if equipped)

1. Pull up on lever (1).
 2. Slide seat forward or backward to desired position.
 3. Release lever to lock in place.
- NOTE: Key must be in the RUN position for raising operator seat. Engine does not have to be started.*
4. Pull up or push down on front seat tab (2) to adjust seat to weight of operator.
 5. See weight indicator (3) for correct adjustment range.
 6. Pull up on handle (4) to recline back of seat to desired comfort.
 7. Flip lumbar knob (5) up to add support to the upper back area. Flip lumbar knob down to add support to the lower back area.

1—Lever

2—Front Seat Tab

3—Weight Indicator

4—Handle

5—Lumbar Knob



Cloth Air Suspension Seat

OUT4001.000051B -19-12NOV09-2/2

TX1066794A—UN—26OCT09

Dome Light

*NOTE: Dome light will turn on when operator sits in seat.
When engine is started dome light will turn off.*

The dome light (1) is located on the right side of the cab ceiling. Push on right or left side of lens to turn on.

1—Dome Light

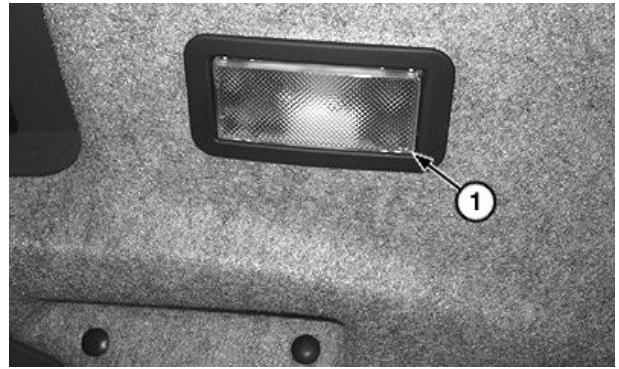

TX1066805A —UN—24OCT09

OUT4001,0000517 -19-05NOV12-1/1

Horn Button—If Equipped

Horn button (1) is located on left joystick (EH machine) or left control lever (manual machine). Push-button to sound horn.

1—Horn Button (if equipped)



EH Control

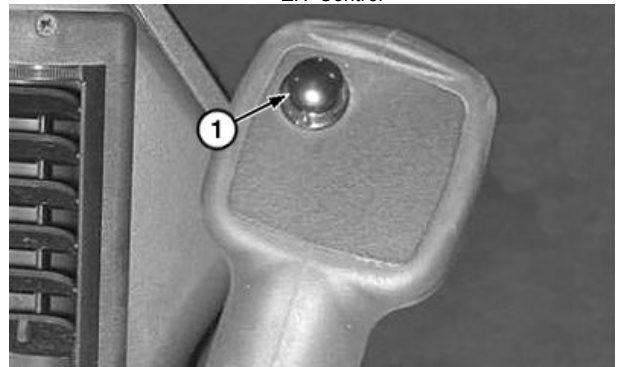

Manual Controls Shown (with optional horn)

TX1066807A —UN—24OCT09

TX1066808A —UN—24OCT09

OUT4001,0000518 -19-16APR13-1/1

Beacon—If Equipped

Beacon light is located on the top of operator's station. Beacon is powered by machine switched power and will be on whenever machine switched power is on.

OUT4001,0000519 -19-15APR13-1/1

Operation—Operating the Machine

Before Starting Work

Review the operating precautions. See **Safety-Operating Precautions. (Section 1-3.)**

Use seat belt when operating machine. Remember to fasten seat belt even during brief periods of use.

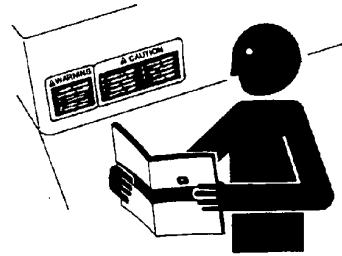

T133566 —UN—24AUG00

DW90712,00005E8 -19-03NOV09-1/1

Operator's Daily Machine Check Before Starting

Safety and Protective Device Checks

Walk around machine to clear all persons from machine area before starting machine.

Check condition of guards, shields, and covers.

Overall Machine Checks

Check for worn or frayed electrical wires and loose or corroded connections.

Check for bent, broken, loose, or missing boom, bucket, or sheet metal parts.

Check for loose or missing hardware.

Check for oil leaks, missing or loose hose clamps, kinked hoses, and lines or hoses that rub against each other or other parts.

TX14740,00000D7 -19-06FEB08-1/1

Entering and Exiting Skid Steer

CAUTION: Prevent possible injury when entering and exiting machine. Maintain three-points of contact at all times. Do not use controls as handholds.

Entering Machine With a Cab Door:

From the side or the front without a bucket attached:

Use the boom step (1), boom handhold (2), and door handle (8) for first step. Use cab handhold (6), door handle, and footwell step (5) for next step.

From the front with a bucket attached: Use bucket step (4), boom handhold (2), and door handle (8) for first step. Continue holding boom handhold and door handle, then step onto boom step (1). Use cab handhold (6), door handle, and footwell step (5) for next step.

When the boom is raised on the boom lock: Enter from the front. Use cab handhold (6), door handle (8), and footwell step (5).

Entering Machine Without a Cab Door:

From the side or the front without a bucket attached:

Use the boom step (1) and boom handholds (2 and 3) for first step. Use cab handholds (6 and 7) and footwell step (5) for next step.

From the front with a bucket attached: Use bucket step (4) and boom handholds (2 and 3) for first step. Continue holding boom handholds and step onto boom step (1). Use cab handholds (6 and 7) and footwell step (5) for next step.

When the boom is raised on the boom lock: Enter from the front. Use cab handholds (6 and 7) and footwell step (5).

Exiting the Machine:

CAUTION: Avoid possible injury from unexpected boom movement. Always lower boom to

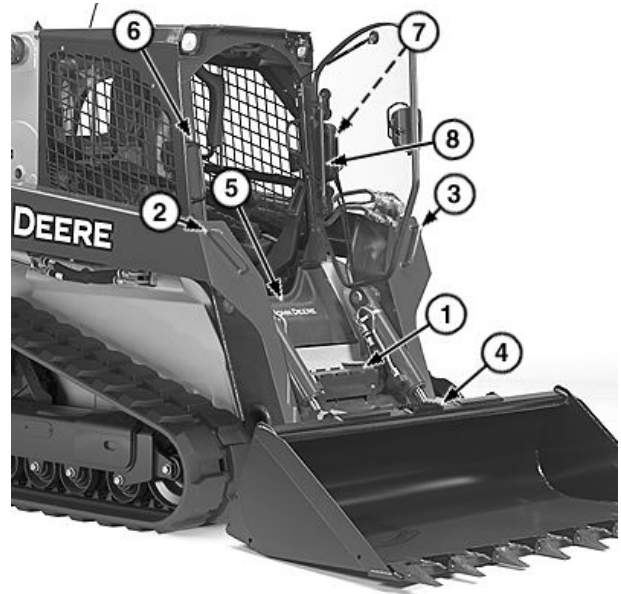

1— Boom Step
2— Boom Handhold
3— Boom Handhold
4— Bucket Step

5— Footwell Step
6— Cab Handhold
7— Cab Handhold
8— Door Handle

the ground or onto boom lock. Always engage the park brake and stop the engine before exiting the machine.

1. Engage park brake and turn key switch to OFF position.
2. Use handholds on inside and outside the cab for support. Step onto the footwell step first, then boom step, then bucket step (if equipped), and then onto the ground.

TX1067271A—UN—13NOV09

OUT4001,000053C -19-04DEC09-1/1

Engine Break-In Period

NOTE: The use of break-in oils is not required for this engine. Perform the following steps to break-in your engine properly during the first 250 hours.

Before starting, fill engine with seasonal viscosity grade oil and coolant meeting specifications. See Diesel Engine Oil and Light Duty Diesel Engine Coolant. (Section 3-1.)

1. During the first 20 hours, avoid prolonged periods of engine idling or sustained maximum load operation. Warm-up engine carefully and operate at normal loads. If engine will idle longer than 5 minutes, stop engine.
2. Check oil level daily or every 10 hours during engine break-in period. If oil must be added during this period, use John Deere Plus-50™ II oil. See Diesel Engine Oil. (Section 3-1.)

Plus-50 is a trademark of Deere & Company.

IMPORTANT: DO NOT operate engine when oil level is below ADD mark on dipstick. Check oil level before starting engine for the first time. See Check Engine Oil Level. (Section 3-4.)

3. Watch oil pressure and coolant temperature closely during break-in period. Also check coolant level daily or every 10 hours and check for leaks.
4. Check alternator belt for proper alignment and seating in pulley grooves.
5. Change oil and oil filter after first 250 hours. Fill crankcase with seasonal viscosity grade oil. See Diesel Engine Oil (Section 3-1.) and Change Engine Oil and Replace Filter. (Section 3-7.)

ER79617,0000C40 -19-18OCT10-1/1

Starting the Engine

1. Fasten seat belt.
2. Lower interlocking seat bar.
3. Be sure all drive and auxiliary hydraulic controls are in neutral.
4. Engage park brake.

NOTE: The engine control unit (ECU) will default engine speed to slow idle on engine startup regardless of engine speed control dial position. Move engine speed control dial to slow idle position and then increase the setting to the desired speed to get the engine speed to increase.

5. Turn engine speed control dial (1) forward to 1/3 position.
6. Turn key switch to RUN position, but do not crank engine.
7. Check engagement and monitor unit (EMU). Engine low oil pressure indicator will be lit until engine starts.

IMPORTANT: Avoid possible machine damage. Do not crank starter continuously for more than 45 seconds or you may damage starter.

Do not use ether or any other type of starting fluid on engines.

Do not tow the machine to start it. Damage to hydrostatic system will occur.

8. Turn key switch to START position.

NOTE: If engine does not start within 45 seconds, turn key switch to OFF position and allow starter to cool for 1 minute before trying again.



1— Engine Speed Control Dial

9. Release key when engine starts.
 - a. A warning light bulb check is performed each time machine is started.

IMPORTANT: To prevent damage of hydraulics and engine in temperatures below 0°C (32°F), run engine at slow idle for 10 minutes before operating controls.

- b. Always allow engine to warm up before applying a load.
10. Run at 1/3 speed for 30 seconds. Do not run at fast or slow idle. Do not accelerate rapidly during warm-up.
 11. Operate machine at less-than-normal loads and speeds until engine is at normal operating temperature.

TX1067021A—JN—28OCT08

OUT4001,0000521 -19-25JUL11-1/1

Cold Weather Starting

NOTE: It is normal for battery voltage indicator to light when glow plugs are active.

NOTE: Recommended oils for improved starting performance, see *Operating in Cold Temperature Climates*. (Section 3-1.)

IMPORTANT: Avoid possible machine damage. Do not crank starter continuously for more than 45 seconds, or the starter may be damaged.

If engine does not start within 45 seconds, turn key switch to OFF position and allow starter to cool for 1 minute before trying again.

Do not use ether or any other type of starting fluid on engines.

Do not tow the machine to start it, or damage to hydrostatic system will occur.

IMPORTANT: To prevent damage to hydraulics and engine in temperatures below 0°C (32°F), run engine at slow idle for 10 minutes before operating controls.

1. Turn key switch to RUN position. If engine coolant temperature is low, the engagement and monitor unit (EMU) will display a glow plug icon, text stating Wait to Start, and the count down of the seconds remaining before the engine should be started.
2. Once countdown is completed, the EMU will display text stating Ready to Start Engine for 2 seconds, and then return to the normal run-time screen.
3. Turn key switch to the START position and release key when engine starts.

OUT4001.0000524 -19-16SEP11-1/1

Engine Block Heater—If Equipped

CAUTION: Prevent possible injury from electrical shock. Use grounded cord and inspect for damage before connecting to power source.

IMPORTANT: Prevent property damage as a result of possible fire from an overheated electrical cord. Use a heavy-duty, grounded cord to connect heater to electrical power.

Supply voltage for engine block heater can be 220 V or 110 V. Ensure the correct engine block heater is used for the correct supply voltage.

NOTE: Engine block heater is recommended when ambient temperature is below 5°F (-15°C).

The engine block heater allows for quicker start and warmup during cold weather temperatures.

Connect engine block heater cord (1) to electrical power a minimum of 4 hours before starting engine.

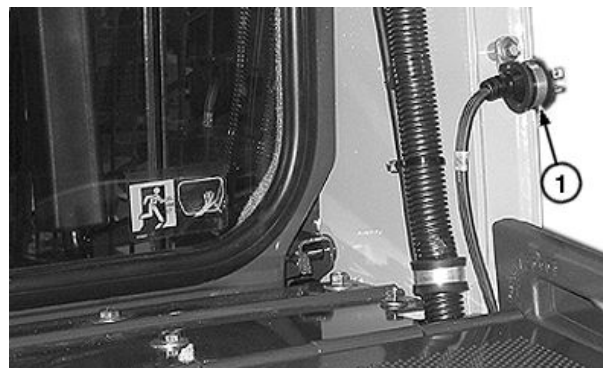

Engine Block Heater Cord

1— Engine Block Heater Cord

TX1067048A —UN—29OCT09

LB82152.0000759 -19-04JAN13-1/1

Engine Speed Control

There are two ways to control engine speed:

- Engine speed control dial (1)
- Engine speed control pedal (2)

All machines will have both the engine speed control dial and engine speed control pedal, unless machine is equipped with hydraulic hand and foot controls, then it will only have the engine speed control dial.

NOTE: The engine control unit (ECU) will default engine speed to slow idle on engine startup regardless of engine speed control dial position. Move engine speed control dial to slow idle position and then increase the setting to the desired speed to get the engine speed to increase.

- 1—Engine Speed Control Dial 2—Engine Speed Control Pedal

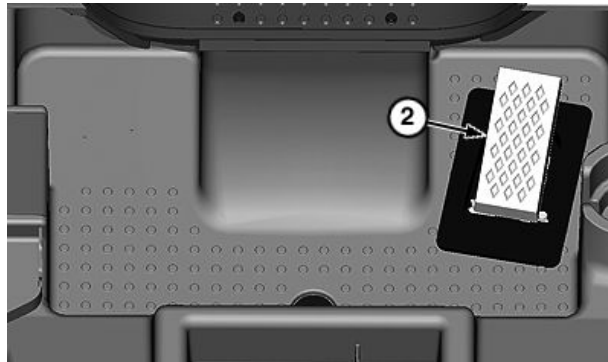

TX1124955 —UN—30OCT12

TX1087049A —UN—29OCT09

OUT4001,0000526 -19-30OCT12-1/1

Stopping the Engine

1. Move steering control levers (manual machines) or joysticks (EH machines) to neutral position to stop machine.
2. Move auxiliary hydraulic controls to neutral position.

CAUTION: Prevent possible injury from unexpected boom movement. Never exit machine with boom raised unless boom is resting on boom lock.

3. Lower boom completely to ground. If boom is to remain in raised position, use boom lock.
4. Engage park brake.
5. Turn engine speed control dial to slow idle position.
6. Turn key switch to OFF position.
7. Raise interlocking seat bar.
8. Release seat belt.

OUT4001,0000527 -19-10NOV09-1/1

Boom Lock

Boom lock (2) is used whenever it is necessary to leave machine with boom in a raised position.

Locking boom in raised position:

1. Remove any attachment.
2. Park machine on level surface.
3. Raise boom a short distance above boom lock.
4. Rotate red boom lock lever (1) towards seat to extend boom lock to locked position.
5. Slowly lower boom onto boom lock.

Disengaging boom lock:

1. Raise boom a short distance off of boom lock.
2. Rotate red boom lock lever away from seat to retract the boom lock to the unlocked position.
3. Slowly lower boom to the ground.

1— Boom Lock Lever

2— Boom Lock

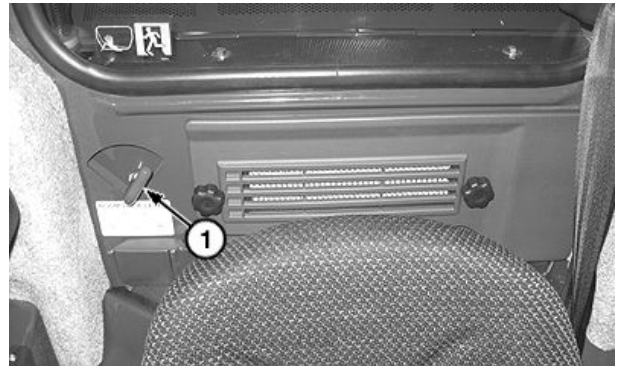

Boom Lock Lever



Boom Lock

TX1067051A—UN—29OCT09

TX1067052A—UN—30OCT09

OUT4001,0000528 -19-10NOV09-1/1

Boom Release

CAUTION: Prevent possible injury from unexpected boom movement. Never exit machine with boom raised unless boom is resting on boom lock.

Boom release mechanism is to be used when boom is in a partially raised position and engine is stopped and will not start.

Manual Controls

1. Close cab door, if equipped.
2. Fasten seat belt.
3. Lower interlocking seat bar.
4. Remove wing screw (1) from cover in lower left corner of cab. Remove cover.
5. Turn key switch to RUN position. Do not start engine.
6. Cycle park brake to middle position.
7. Pull up handle (2) and hold.
8. Actuate boom function:
 - For Hand and Foot Machine—press down on front of left pedal.
 - For Hands Only Machine—pivot left control lever towards operator.
9. Lower boom.

EH Controls

1. Close cab door, if equipped.
2. Fasten seat belt.
3. Lower interlocking seat bar.
4. Turn key switch to RUN position. Do not start engine.



Boom Release Cover



Boom Release Handle

1—Wing Screw

2—Handle

5. Cycle park brake to middle position.
6. Actuate boom function by moving right joystick forward.
7. Lower boom.

If boom does not lower, see your authorized dealer.

OUT4001,0000529 -19-14JAN11-1/1

TX1067098A—UN—30OCT09

TX1067099A—UN—30OCT09

Steering—Manual Controls

To steer the machine:

NOTE: The left control lever (1) controls left drive and the right control lever (2) controls right drive.

- Push both control levers forward at the same time to go forward.
- Pull both control levers back at the same time to go backward.
- Push one control lever forward and pull the other control lever back at the same time to make a short turn.
- Slowly return control levers to neutral position to stop.

1— Left Control Lever

2— Right Control Lever

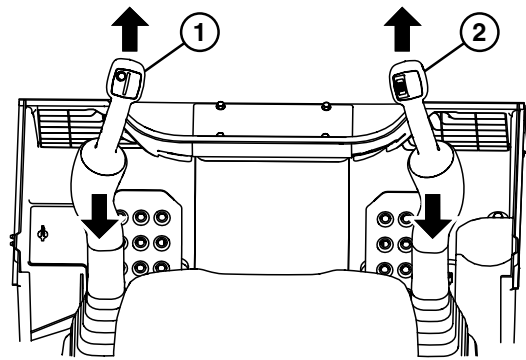

Hand and Foot Machine Shown

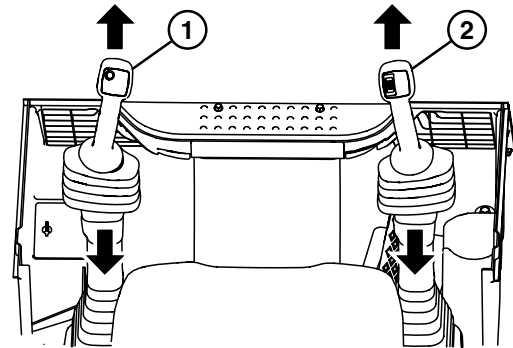

Hands Only Machine Shown

OUT4001,000052A -19-04NOV09-1/1

TX1067108—UN—03NOV09

TX1067109—UN—03NOV09

Operating Boom—Manual Controls

Hand and Foot Machines

The left foot pedal (1) controls the boom:

- Push back of foot pedal down to raise boom.
- Push front of foot pedal down to lower boom.
- Boom will move faster the farther the foot pedal is pushed down.
- Foot pedal will return to neutral-hold position when released if not in float position.

Float position:

Relieves down pressure on boom cylinders, and allows boom and attachment to float with contour of the ground.

- Push front of foot pedal down into detent position to engage float. Boom will stay in float until the rear of foot pedal is pushed down.

1— Left Foot Pedal

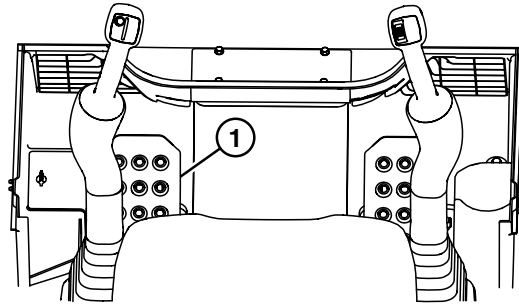

Left Foot Pedal

TX1068061—UN—20NOV09

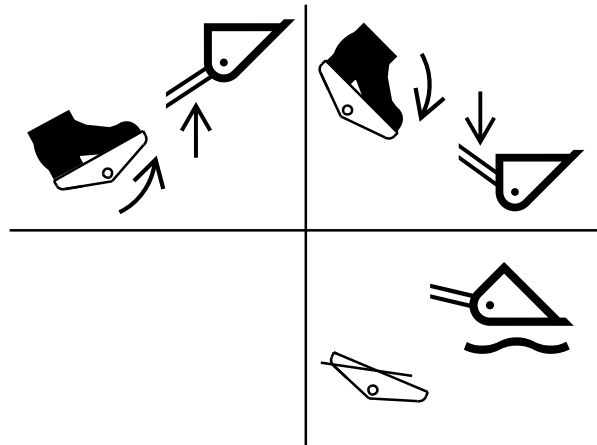

Left Foot Pedal Operation—Hand and Foot Machine

TX1067116—UN—04NOV09

Continued on next page

OUT4001.000052C -19-20NOV09-1/2

Hands Only Machines

The left control lever (2) controls the boom:

- Pivot control lever left to raise boom.
- Pivot control lever right to lower boom.
- Boom will move faster the farther the control lever is moved.

Float position:

Relieves down pressure on boom cylinders, and allows boom and attachment to float with contour of the ground.

- Push control lever down toward seat and into detent position to engage float.

2— Left Control Lever

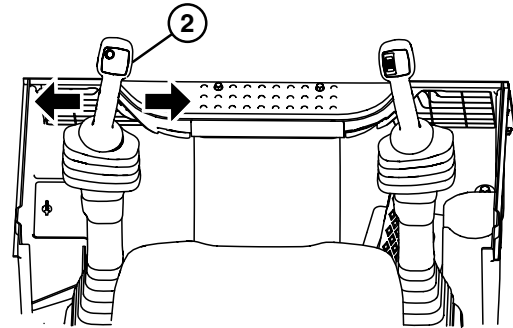

TX1067297 —UN—05NOV09

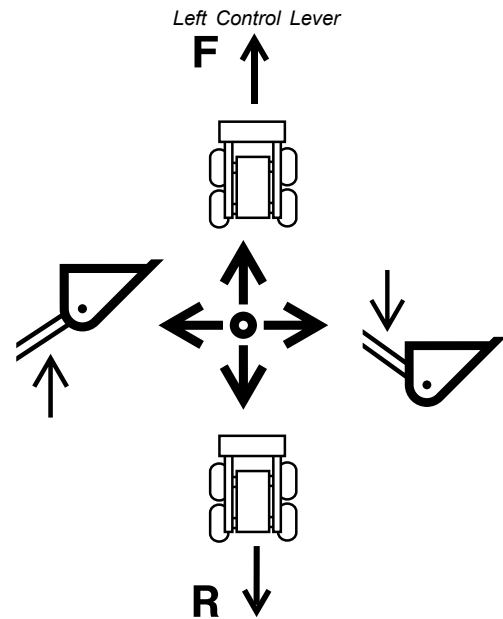

Left Control Lever Operation—Hands Only Machine

TX1067119 —UN—04NOV09

OUT4001,000052C -19-20NOV09-2/2

Operating Bucket—Manual Controls

Hand and Foot Machines

The right foot pedal (1) controls the bucket:

- Push back of foot pedal down to roll bucket back.
- Push front of foot pedal down to dump bucket.
- Bucket will move faster the farther the foot pedal is pushed down.
- Foot pedal will return to neutral-hold position when it is released.

1—Right Foot Pedal

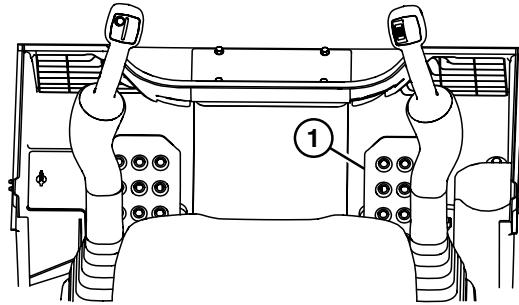

Right Foot Pedal

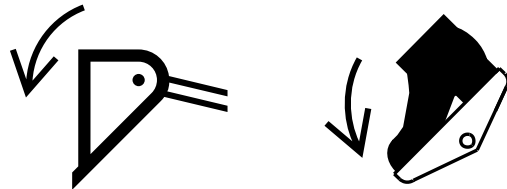
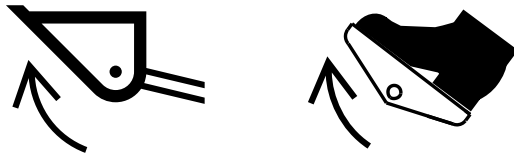

Right Foot Pedal Operation—Hand and Foot Machine

TX1067303 —UN—04NOV09

TX1067117 —UN—04NOV09

Continued on next page

OUT4001,000052E -19-10NOV09-1/2

Hands Only Machines

The right control lever (2) controls the bucket:

- Pivot control lever left to roll back bucket.
- Pivot control lever right to dump bucket.
- Bucket will move faster the farther the control lever is moved.

2— Right Control Lever

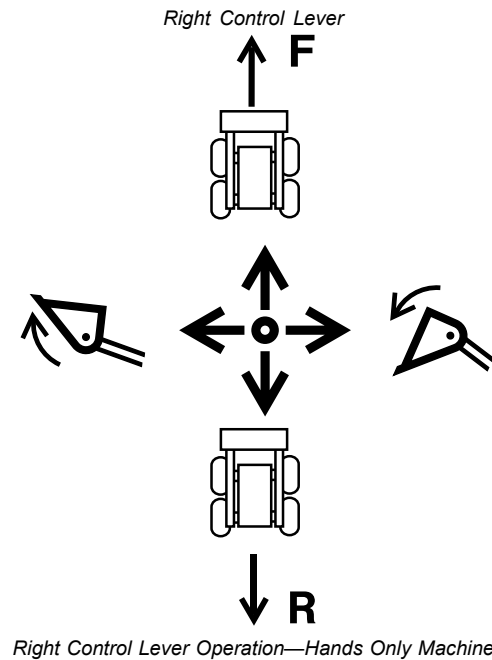
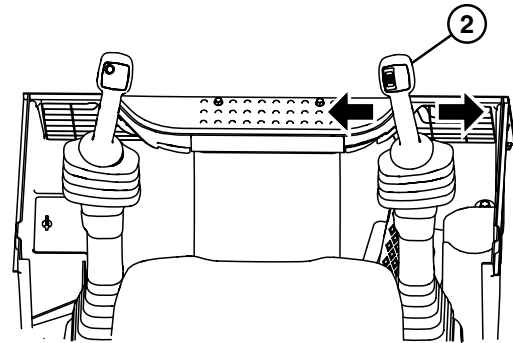

OUT4001.000052E -19-10NOV09-2/2

TX1067302 —UN—04NOV09

TX1067118 —UN—04NOV09

Steering—EH Controls

CAUTION: Avoid possible injury from unexpected machine movement. If EH machine is equipped with performance package, be aware that there are two control patterns available. Always verify control response before operating machine.

Steering on EH machine will use an ISO pattern, unless the optional performance package is ordered that includes the ability to switch from ISO pattern to H pattern depending on operator preference.

EH Machine

To steer machine using ISO pattern:

NOTE: The left joystick (1) controls left and right drive.

- Move left joystick in the direction of desired travel.

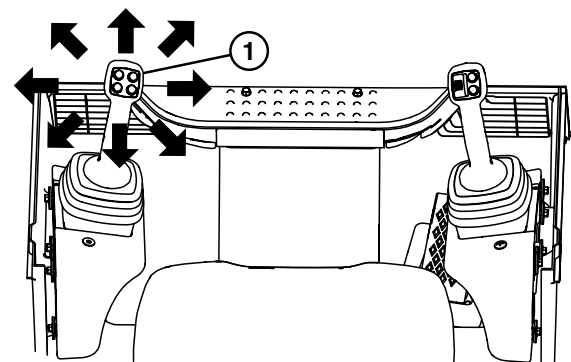

1— Left Joystick

ISO Pattern

- Slowly return left joystick to neutral position to stop.

Continued on next page

OUT4001.000052B -19-11APR11-1/2

TX1067217 —UN—04NOV09

EH Machine With Performance Package—if equipped

If EH machine is equipped with performance package, steering control can be easily switched between ISO pattern or H pattern for desired operator preference.

NOTE: The active pattern—ISO Pattern Selected or H Pattern Selected—will be displayed on engagement and monitor unit (EMU) at machine startup and anytime the pattern is changed.

Press upper half of pattern select switch (3) for H pattern.
Press bottom half of pattern select switch for ISO pattern.

To steer machine using H pattern:

NOTE: The left joystick (1) controls left drive and the right joystick (2) controls right drive.

- Press upper half of pattern select switch for H pattern.
- Push both joysticks forward at the same time to go forward.
- Pull both joysticks back at the same time to go backward.
- Push one joystick forward and pull the other joystick back at the same time to make a short turn.
- Slowly return joysticks to neutral position to stop.

1— Left Joystick
2— Right Joystick

3— Pattern Select Switch

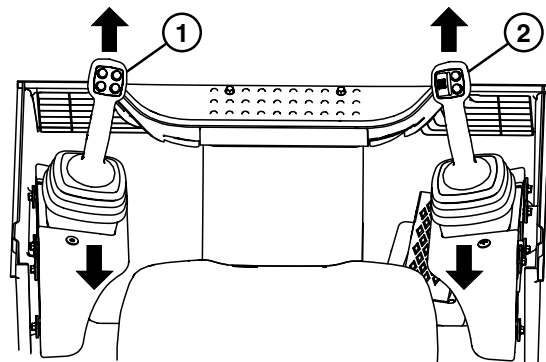

Optional H Pattern



Pattern Select Switch

TX1067110 —UN—03NOV09

TX1067227A —UN—03NOV09

OUT4001,000052B -19-11APR11-2/2

Operating Boom—EH Controls

CAUTION: Avoid possible injury from unexpected machine movement. If EH machine is equipped with performance package, be aware that there are two control patterns available. Always verify control response before operating machine.

ISO Pattern

The right joystick (1) controls the boom:

- Move joystick forward to lower boom.
- Move joystick backward to raise boom.
- Boom will move faster the farther the joystick is moved.

Float position:

Relieves down pressure on boom cylinders, and allows boom and attachment to float with contour of the ground.

NOTE: Do not press and hold float switch (2). Holding float switch can result in a diagnostic trouble code.

To activate float:

1. Activate boom down motion.
2. Press and release float switch (2).
3. Allow joystick to move to neutral position.

NOTE: Pressing float switch again will not deactivate float.

To deactivate float:

1. Move joystick a minimum of 10% in either direction.

1— Right Joystick

2— Float Switch

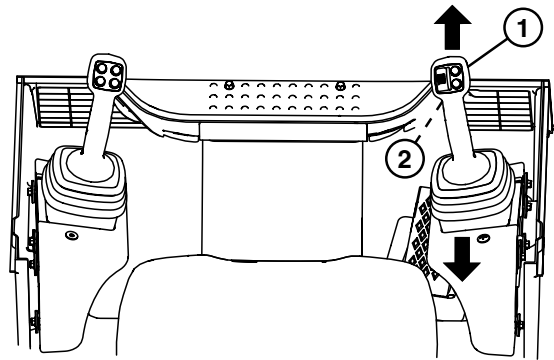

Right Joystick

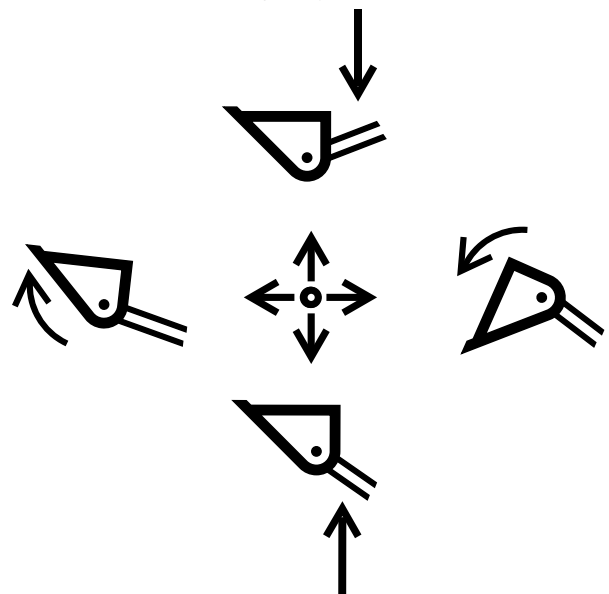

Right Joystick Operation—ISO Pattern

Continued on next page

OUT4001.000052D -19-25JUN13-1/2

TX1067298—UN—05NOV09

TX1067123—UN—04NOV09

H Pattern

The left joystick (3) controls the boom:

- Pivot joystick to the left to raise boom.
- Pivot joystick to the right to lower boom.
- Boom will move faster the farther the joystick is moved.

NOTE: Do not press and hold float switch (4). Holding float switch can result in a diagnostic trouble code (DTC).

To activate float:

1. Activate boom down motion.
2. Press and release float switch (4).
3. Allow joystick to move to neutral position.

NOTE: Pressing float switch again will not deactivate float.

To deactivate float:

1. Move joystick a minimum of 10% in either direction.

3—Left Joystick

4—Float Switch

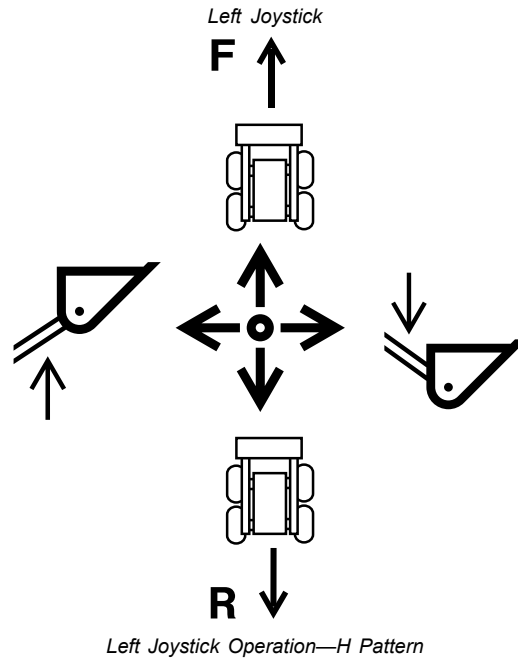
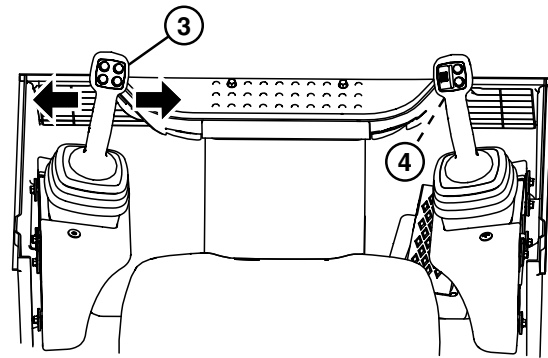

Left Joystick Operation—H Pattern

TX1067299—UN—05NOV09

TX1067122—UN—04NOV09

OUT4001,000052D -19-25JUN13-2/2

Operating Bucket—EH Controls

CAUTION: Avoid possible injury from unexpected machine movement. If EH machine is equipped with performance package, be aware that there are two control patterns available. Always verify control response before operating machine.

ISO Pattern

The right joystick (1) controls the bucket:

- Pivot joystick left to roll back bucket.
- Pivot joystick right to dump bucket.
- Bucket will move faster the farther the joystick is moved.

1— Right Joystick

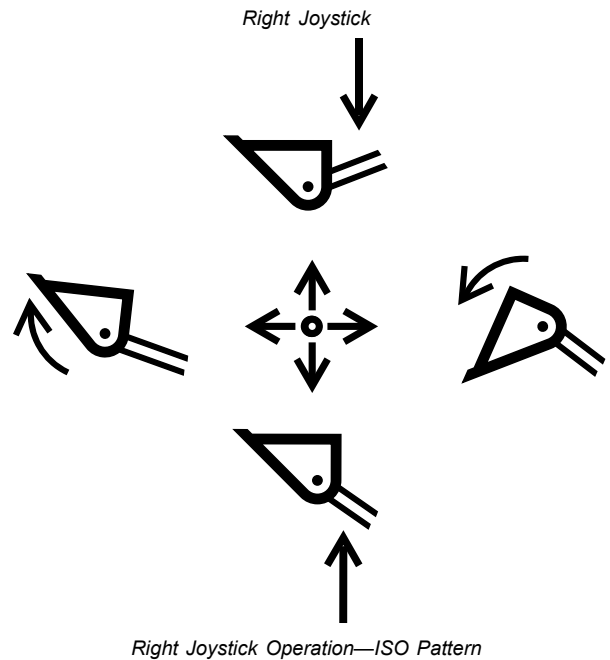
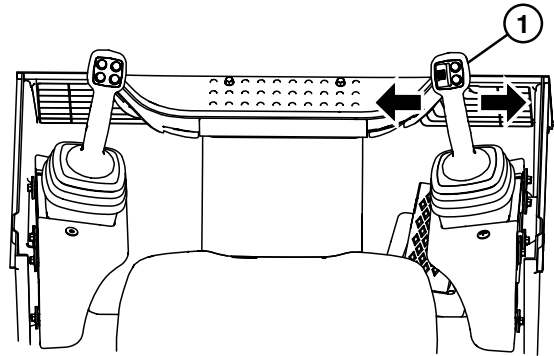

TX1067301—UN—04NOV09

TX1067123—UN—04NOV09

Continued on next page

OUT4001,000052F -19-10NOV09-1/2

H Pattern

The right joystick (1) controls the bucket:

- Pivot joystick left to roll back bucket.
- Pivot joystick right to dump bucket.
- Bucket will move faster the farther the joystick is moved.

1—Right Joystick

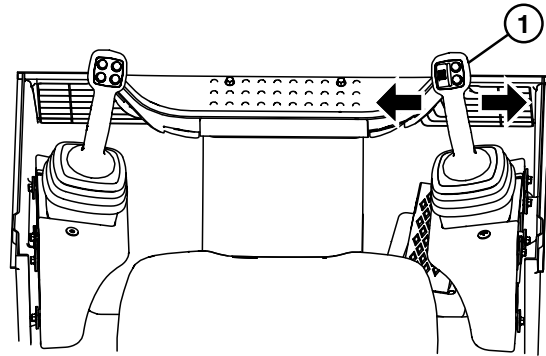

TX1067301—UN—04NOV09

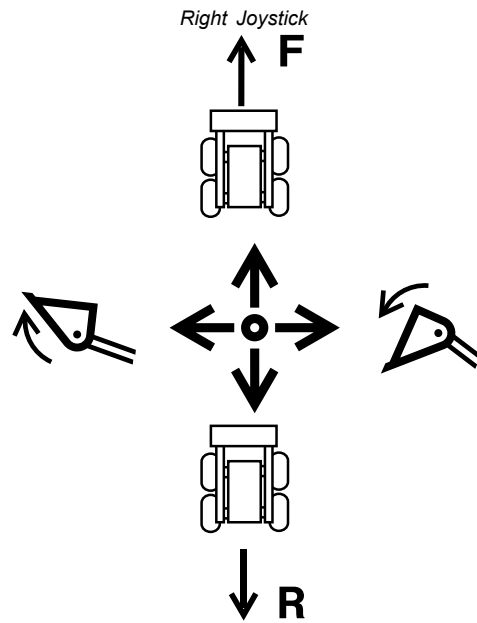

TX1067124—UN—04NOV09

Right Joystick Operation—H Pattern

OUT4001,000052F -19-10NOV09-2/2

Operating Auxiliary Hydraulics

Manual Controls

For manual controls, use right control lever (2) to operate auxiliary hydraulic functions. Connect attachment to standard male and female couplers (7 and 8). Roll auxiliary proportional switch (4) forward or backward to vary hydraulic flow rate and direction depending on desired attachment function. Releasing the auxiliary proportional switch stops all auxiliary hydraulic flow.

To set continuous auxiliary flow, press and release auxiliary flow set switch (3) while the proportional switch is actuated in the desired direction. This will set the auxiliary hydraulics to run at full flow in the direction selected. Continuous auxiliary hydraulic flow will continue without pressing the auxiliary proportional switch. If continuous flow is active and the auxiliary proportional switch is moved in either direction or the flow set switch is pressed, continuous flow will be cancelled and proportional auxiliary hydraulic flow will resume.

If operator needs to exit the machine with hydraulics enabled, press upper half of auxiliary hydraulic override switch (5) momentarily to activate bypass mode. The message, Auxiliary Override, will appear on engagement and monitor unit (EMU) display and alarm will sound.

IMPORTANT: Avoid attachment damage. Only use high flow switch (6) with high flow attachments.

If attachment requires a high hydraulic flow rate to operate, connect attachment to high flow male and female couplers (9 and 10), if equipped. Press upper half of high flow switch (6) momentarily to activate high flow option. Amber hydraulic high flow icon will appear on EMU.

IMPORTANT: Prevent damage to the attachment motor, always connect attachment case drain coupler (11) first when installing attachment and disconnect last when removing attachment.

NOTE: Attachment case drain coupler is only used when required by attachment.

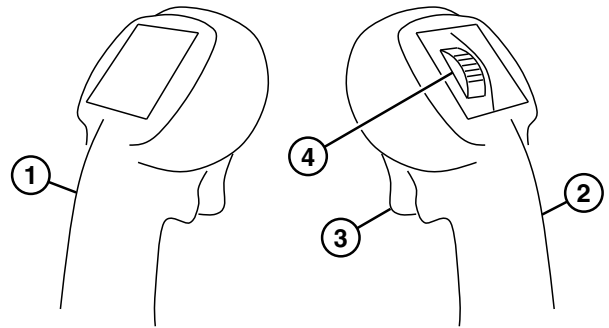

Manual Controls



Auxiliary Override and High Flow Switches

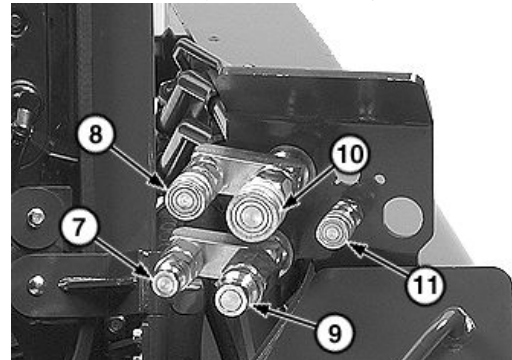

High Flow Shown

- | | |
|--|---|
| 1— Left Control Lever | 7— Standard Male Coupler |
| 2— Right Control Lever | 8— Standard Female Coupler |
| 3— Auxiliary Flow Set Switch | 9— High Flow Male Coupler (if equipped) |
| 4— Auxiliary Proportional Switch | 10— High Flow Female Coupler (if equipped) |
| 5— Auxiliary Hydraulic Override Switch | 11— Attachment Case Drain Coupler (if equipped) |
| 6— High Flow Switch (if equipped) | |

Continued on next page

OUT4001,0000530 -19-31JAN13-1/3

TX1066657 —UN—22OCT09

TX1067192A —UN—03NOV09

TX1067104A —UN—03NOV09

Manual Machine With Attachment Controls

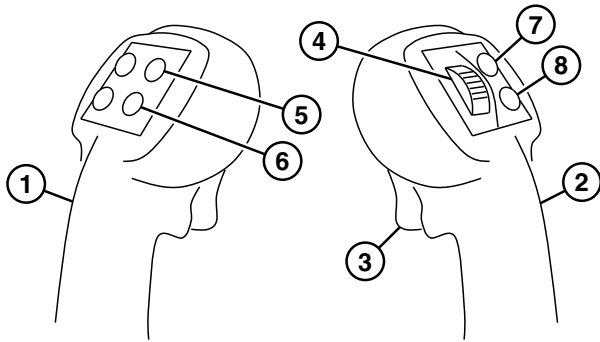

Manual Machine With Attachment Controls

TX1067177 —UN—04NOV09



Auxiliary Override, High Flow, and Aux. Fourth Function Switches

TX1067181A —UN—02NOV09

For manual machine with attachment controls, use left and right control levers (1 and 2) to operate auxiliary hydraulic functions. Connect attachment to standard male and female couplers (12 and 13). Roll auxiliary proportional switch (4) forward or backward to vary hydraulic flow rate and direction depending on desired attachment function. Releasing the auxiliary proportional switch stops all auxiliary hydraulic flow.

To set continuous auxiliary flow, press and release auxiliary flow set switch (3) while the proportional switch is actuated in the desired direction. This will set the auxiliary hydraulics to run at full flow in the direction selected. Continuous auxiliary hydraulic flow will continue without pressing the auxiliary proportional switch. If continuous flow is active and the auxiliary proportional switch is moved in either direction or the flow set switch is pressed, continuous flow will be cancelled and proportional auxiliary hydraulic flow will resume.

If operator needs to exit the machine with hydraulics enabled, press upper half of auxiliary hydraulic override switch (9) momentarily to activate bypass mode. The message, Auxiliary Override, will appear on engagement and monitor unit (EMU) display and alarm will sound.

If attachment is equipped with electric 14-pin connector (17), use auxiliary second and third function switches 5, 6, 7, and 8 and auxiliary fourth function switch (11) to operate attachment.

If attachment is equipped with electric 3-pin connector (18), use auxiliary third function switches to operate attachment. Consult attachment operator's manual for attachment functions controlled by these switches.

IMPORTANT: Avoid attachment damage. Only use high flow switch (10) with high flow attachments.

If attachment requires a high hydraulic flow rate to operate, connect attachment to high flow male and female

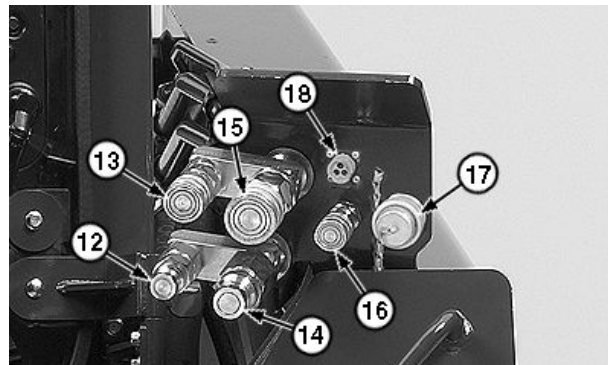

High Flow and Attachment Control Shown

TX1067105A —UN—02NOV09

- | | |
|---|--|
| 1— Left Control Lever | 10— High Flow Switch (if equipped) |
| 2— Right Control Lever | 11— Auxiliary Fourth Function Switch (if equipped) |
| 3— Auxiliary Flow Set Switch | 12— Standard Male Coupler |
| 4— Auxiliary Proportional Switch | 13— Standard Female Coupler |
| 5— Auxiliary Third Function A Switch (if equipped) | 14— High Flow Male Coupler (if equipped) |
| 6— Auxiliary Third Function B Switch (if equipped) | 15— High Flow Female Coupler (if equipped) |
| 7— Auxiliary Second Function A Switch (if equipped) | 16— Attachment Case Drain Coupler (if equipped) |
| 8— Auxiliary Second Function B Switch (if equipped) | 17— Electric 14-Pin Connector (if equipped) |
| 9— Auxiliary Hydraulic Override Switch | 18— Electric 3-Pin Connector (if equipped) |

couplers (14 and 15), if equipped. Press upper half of high flow switch (10) momentarily to activate high flow option. Amber hydraulic high flow icon will appear on EMU.

NOTE: Attachment case drain coupler (16) is only used when required by attachment.

Continued on next page

OUT4001,0000530 -19-31JAN13-2/3

EH Controls

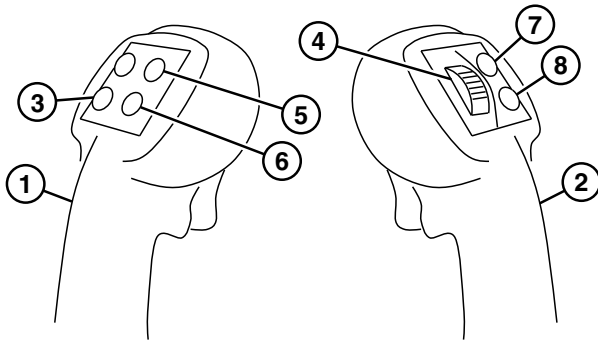

EH Controls



Auxiliary Override, High Flow, and Aux. Fourth Function Switches

For EH controls, use left and right joysticks (1 and 2) to operate auxiliary hydraulic functions. Connect attachment to standard male and female couplers (12 and 13). Roll auxiliary proportional switch (4) forward or backward to vary hydraulic flow rate and direction depending on desired attachment function. Releasing the auxiliary proportional switch stops all auxiliary hydraulic flow.

To set continuous auxiliary flow, press and release the auxiliary flow set switch (3) while the proportional switch is actuated in the desired direction. This will set the auxiliary hydraulics to run at full flow in the direction selected. Continuous auxiliary hydraulic flow will continue without pressing the auxiliary proportional switch. If continuous flow is active and the auxiliary proportional switch is moved in either direction or the flow set switch is pressed, continuous flow will be cancelled and proportional auxiliary hydraulic flow will resume.

If operator needs to exit the machine with hydraulics enabled, press upper half of auxiliary hydraulic override switch (9) momentarily to activate bypass mode. The message, Auxiliary Override, will appear on engagement and monitor unit (EMU) display and alarm will sound.

If attachment is equipped with electric 14-pin connector (17), use auxiliary second and third function switches 5, 6, 7, and 8 and auxiliary fourth function switch (11) to operate attachment.

If attachment is equipped with electric 3-pin connector (18), use auxiliary third function switches to operate attachment. Consult attachment operator's manual for attachment functions controlled by these switches.

IMPORTANT: Avoid attachment damage. Only use high flow switch (10) with high flow attachments.

If attachment requires a high hydraulic flow rate to operate, connect attachment to high flow male and female

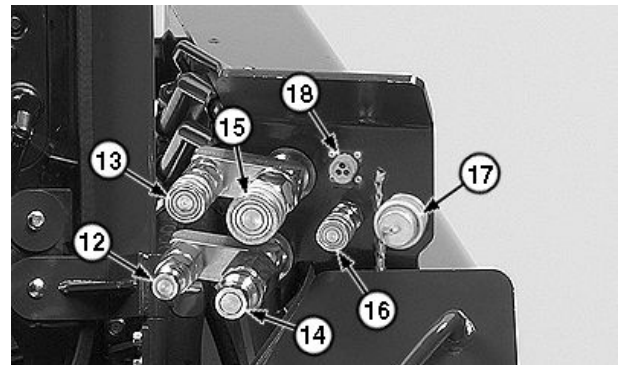

High Flow and Attachment Control Shown

- | | |
|--|--|
| 1— Left Joystick | 10— High Flow Switch (if equipped) |
| 2— Right Joystick | 11— Auxiliary Fourth Function Switch (if equipped) |
| 3— Auxiliary Flow Set Switch | 12— Standard Male Coupler |
| 4— Auxiliary Proportional Switch | 13— Standard Female Coupler |
| 5— Auxiliary Third Function A Switch | 14— High Flow Male Coupler (if equipped) |
| 6— Auxiliary Third Function B Switch | 15— High Flow Female Coupler (if equipped) |
| 7— Auxiliary Second Function A Switch | 16— Attachment Case Drain Coupler (if equipped) |
| 8— Auxiliary Second Function B Switch | 17— Electric 14-Pin Connector (if equipped) |
| 9— Auxiliary Hydraulic Override Switch | 18— Electric 3-Pin Connector (if equipped) |

couplers (14 and 15), if equipped. Press upper half of high flow switch (10) momentarily to activate high flow option. Amber hydraulic high flow icon will appear on EMU.

NOTE: Attachment case drain coupler (16) is only used when required by attachment.

Hydraulic System Pressure Release—EH Controls

⚠ CAUTION: To avoid injury from escaping fluid under pressure, stop engine and relieve the pressure in the system before disconnecting or connecting hydraulic or other lines. Tighten all connections before applying pressure.

Use this procedure to relieve trapped hydraulic system pressure before performing hydraulic system repairs or tests.

1. Sit in seat. Close cab door if equipped.
2. Lower interlocking seat bar.
3. Turn key to run position. Do not start engine.
4. Switch park brake switch to middle position to engage hydraulic functions.

5. Raise and then lower interlocking seat bar.

⚠ CAUTION: To prevent crushing injury, only perform hydraulic system pressure release with boom down or boom up with boom lock engaged. To lower boom manually, see Boom Release in this section.

6. Cycle both the boom and bucket functions.
7. Stop cycling functions once pressure has been released.
8. Cycle auxiliary hydraulic functions.
9. Stop cycling auxiliary hydraulic functions once pressure has been released.
10. Engage park brake and turn key switch to off.

KH31969,0000016 -19-25MAR11-1/1

Hydraulic System Pressure Release—Manual Controls

⚠ CAUTION: To avoid injury from escaping fluid under pressure, stop engine and relieve the pressure in the system before disconnecting or connecting hydraulic or other lines. Tighten all connections before applying pressure.

This procedure is to relieve trapped hydraulic system pressure before performing hydraulic system repairs or tests.

1. Sit in seat. Close cab door if equipped.
2. Lower interlocking seat bar.
3. Turn key to run position. Do not start engine.
4. Switch park brake switch to middle position to engage hydraulic functions.
5. Raise and then lower interlocking seat bar.
6. Remove access cover (9).



Boom Release Handle Access Cover

9— Access Cover

TX1066128A—JUN—05APR10

Continued on next page

KH31969,0000017 -19-22SEP11-1/2

7. Pull up on boom release handle (123) and hold.

⚠ CAUTION: To prevent crushing injury, only perform hydraulic system pressure release with boom down or boom up with boom lock engaged. To lower boom manually, see **Boom Release** in this section.

8. Cycle both the boom and bucket functions.
9. Stop cycling functions once pressure has been released.
10. Cycle auxiliary hydraulics function.
11. Stop cycling auxiliary hydraulics function once pressure has been released.
12. Engage park brake and turn key switch to off.

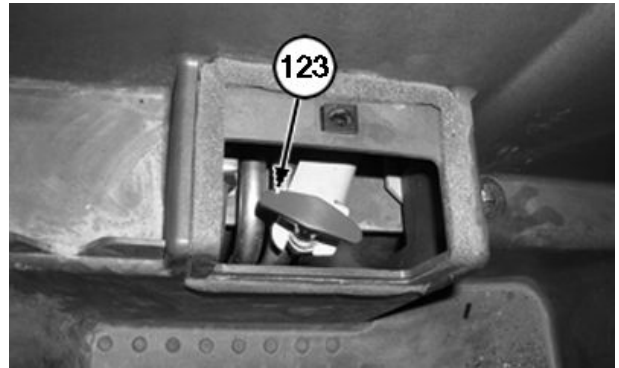

Boom Release Handle

123— Boom Release Handle

TX1066129A —UN—29OCT09

KH31969,0000017 -19-22SEP11-2/2

Using Attachment Mounting System—Quik-Tatch™

Manual Quik-Tatch™

CAUTION: Prevent possible injury from unexpected machine movement. Be careful not to pinch hands between latch handle and step or latch handle and attachment. **DO NOT** try to latch or unlatch handles from operator's station.

Installing an attachment:

1. Park machine on level surface.
2. Lift latch handles (1) up to unlatched position. Be sure latch handles are all the way up so lock pins are fully retracted.
3. Enter machine, fasten seat belt, and lower interlocking seat bar. Start engine. Disengage park brake.
4. Tilt mounting plates (2) forward.
5. Drive forward. Raise boom and guide top of mounting plates under attachment mounting brackets (3).
6. Raise and roll back mounting plates. The back of attachment should rest against front of mounting plates.
7. When attachment is fully supported, lower boom until boom is resting on boom stops.
8. Roll attachment out, stopping with bottom edge of attachment about 50 mm (2 in.) from ground.
9. Engage park brake, stop engine, raise interlocking seat bar, unfasten seat belt and exit machine.
10. Push the two latch handles down to lock attachment to Quik-Tatch™.
11. Enter machine, fasten seat belt, and lower interlocking seat bar.
12. Start engine and disengage park brake.
13. Activate boom cylinders to raise attachment and extend bucket cylinders to tilt attachment at a slight downward angle so that bottom of Quik-Tatch™ is visible.
14. Visually inspect attachment mechanism to verify that pins are fully engaged in slots on back of attachment.

CAUTION: Prevent possible crushing injury from falling attachment. Be sure pins and latch handles are secure before operating boom and bucket.

If attachment is not securely latched, follow the removal procedure, and then repeat installation procedure.

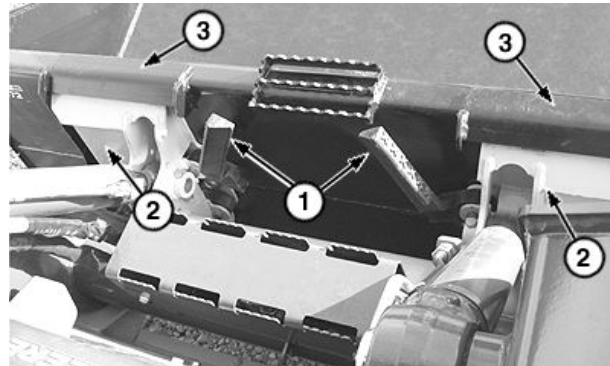

Manual Quik-Tatch™

1— Latch Handle (2 used)
2— Mounting Plate (2 used)

3— Mounting Bracket (2 used)

IMPORTANT: Avoid excessive pin wear. Keep the pin area clear of dirt and debris. If the pin will not fully engage or if wear is detected, see your authorized dealer.

15. Before connecting hydraulic hoses, relieve hydraulic system pressure. See Hydraulic System Pressure Release. (Section 2-2.)
16. Connect attachment hydraulic hoses and electrical connections to machine, if equipped.

Removing the attachment:

1. Park machine.
2. Lower boom until attachment is securely resting on ground.
3. Disconnect hydraulic hoses from couplers, if needed.
4. Pull latch handles up to unlatched position to release pins from lower attachment tabs. Be sure latch handles are fully raised.
5. Enter machine, fasten seat belt, and lower interlocking seat bar.
6. Start engine and disengage park brake.
7. Tilt mounting plate forward and back machine away from attachment at the same time.

CAUTION: Prevent possible crushing injury from falling attachment. Be sure attachment is on the ground before continuing.

Quik-Tatch is a trademark of Deere & Company

Continued on next page

OUT4001,0000532 -19-23MAR11-1/2

TX1067234A —UN—03NOV09

Electric Quik-Tatch™

Installing an attachment:

1. Park machine on level surface.
2. Lower boom until boom is resting on boom stops.
3. Disengage park brake.

NOTE: The switch will automatically return to center position when released. The mounting plates will stop at the position they are in at the time the switch is released.

4. Press and hold lower half of Quik-Tatch™ switch (1) to retract lock pins. Red indicator should be visible in indicator window (2).
5. Tilt mounting plates (3) forward.
6. Drive forward and raise boom. Guide top of mounting plates under attachment mounting brackets.
7. Raise and rollback mounting plates. Back of attachment should rest against front of mounting plates.
8. Lower boom until boom is resting on boom stops when attachment is fully supported.
9. Roll attachment out. Stop with bottom edge of attachment 50 mm (2 in.) from ground.
10. Press and hold upper half of Quik-Tatch™ switch to engage lock pins. Red indicator should not be visible in indicator window.
11. Activate lift cylinders to raise attachment and extend bucket cylinders to tilt attachment at a slight downward angle so that the bottom of the Quik-Tatch™ is visible.

CAUTION: Prevent possible crushing injury from falling attachment. Be sure pins are engaged before operating boom and bucket. Red indicator should not be visible in the indicator window.

If attachment is not securely latched, follow the removal procedure, and then repeat installation procedure.

12. Visually inspect attachment mechanism to verify that pins are fully engaged in slots on back of attachment.
13. Connect hydraulic hoses to couplers, if needed.

Removing the attachment:

1. Park machine on level surface.



Electric Quik-Tatch™ Switch

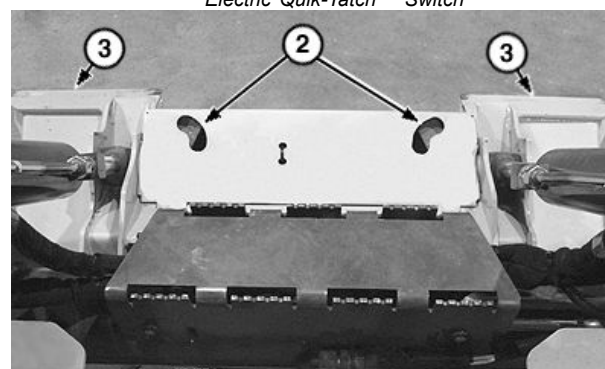

Electric Quik-Tatch™

- 1— Quik-Tatch™ Switch 3— Tilt Mounting Plate (2 used)
2— Indicator Window (2 used)

CAUTION: Prevent possible crushing injury from falling attachment. Be sure attachment is on the ground before continuing.

2. Lower boom until attachment is securely resting on ground.
3. If attachment does not have hydraulic hoses connected to couplers, proceed to step 4.

If attachment does have hydraulic hoses connected to couplers:

- Engage park brake and stop engine.
 - Raise interlocking seat bar and unfasten seat belt.
 - Disconnect hydraulic hoses from couplers.
 - Enter machine, fasten seat belt and lower interlocking seat bar.
 - Start engine and disengage park brake.
4. Press and hold lower half of Quik-Tatch™ switch to retract lock pins. Red indicator should be visible in indicator window.
 5. Tilt mounting plate forward and back machine away from attachment at the same time.

Quik-Tatch is a trademark of Deere & Company

OUT4001,0000532 -19-23MAR11-2/2

TX1067250A —UN—04NOV09

TX1067235A —UN—05NOV09

Self Leveling Hydraulics—If Equipped

If machine is equipped with self leveling option, the attachment will remain in same relative position as the boom is raised.

NOTE: Self leveling is only operational during boom raise function.

Press upper half of self leveling switch (1) to activate this feature. Press lower half of self leveling switch to deactivate.

1—Self Leveling Switch



TX1067211A—UN—03NOV09

OUT4001,0000534 -19-06NOV09-1/1

High Flow Hydraulics—If Equipped

IMPORTANT: Avoid attachment damage. Only use high flow switch (1) with high flow attachments.

If machine is equipped with high flow hydraulics and attachment requires a high hydraulic flow rate to operate, connect attachment to high flow male and female couplers. (See Operating Auxiliary Hydraulics in this section.)

Push upper half of high flow switch (1) momentarily to turn ON and activate high flow option. Amber hydraulic high flow icon will appear on EMU. Push upper half of switch again to turn high flow option OFF.

1—High Flow Switch



TX1067231A—UN—03NOV09

OUT4001,0000535 -19-03NOV09-1/1

Creep Mode Operation—If Equipped

NOTE: Creep mode only works with ISO control pattern selected.

When creep mode is active, the control pattern cannot be changed and the monitor will not indicate a change. Creep mode must be deactivated before the pattern can change.

Creep mode is only available with EH controls and is included as part of the optional performance package.

Creep mode is used to limit the travel speed of the machine when the joystick is at full travel.

To activate creep mode, press creep mode switch (1) to ON position and move the joystick to neutral. For two speed machines, if machine is in high range prior to actuation of the switch, the machine will also shift to low range when the joystick is in neutral.

Once the creep mode switch is turned on, the engagement and monitor unit (EMU) will display the speed limit setting screen. The creep mode limit will come up at the last setting. The operator can press the NEXT or BACK button of the EMU to increase or decrease, respectively, the speed limit setting. This number will become immediately active to control the speed. Therefore, the speed limit can be adjusted while the machine is moving. The display will show the percentage of allowed maximum speed in



Creep Mode Switch

1— Creep Mode Switch

increments of 5% above 10%, and in increments of 1% below 10%. If the MENU or SELECT button is pressed, the display will return to the previous menu display and the operator is allowed to again navigate the display as normal. The operator can return to the speed limit setting screen by either cycling the creep mode switch off and then on again or by navigating the menus and selecting creep mode.

When machine is in creep mode, the creep mode indicator (snail) will illuminate on EMU.

OUT4001,0000536 -19-12OCT10-1/1

TX1067111A—UN—31OCT09

Auto Idle Operation

Auto idle can be enabled or disabled based on a selection in the engagement and monitor unit (EMU) operator menus.

Auto Idle—Manual Controls

Auto idle automatically commands the engine to idle speed if the engine is left running at a speed greater than slow idle for more than 5 seconds, the operator is not in the machine, and auxiliary hydraulics are not enabled.

Auto idle will become **active** if ALL of the following are true:

1. Engine is running.
2. It has been more than 30 seconds since engine start.
3. Operator is out of the seat.
4. Engine speed control dial or engine speed control pedal is more than 5% above idle.
5. Auxiliary hydraulics are not enabled.
6. Items 1—5 have been true for longer than 5 seconds.

NOTE: AUTO IDLE will be displayed on the EMU when machine is in auto idle mode.

To deactivate auto idle, rotate engine speed control dial to slow idle then back to desired engine speed.

NOTE: Auto idle is also deactivated if engine is shut off.

Auto Idle—EH Controls

Auto idle automatically commands the engine to idle speed if the engine is left running at a speed greater than slow idle with no activation of travel, hydraulic, or auxiliary hydraulic functions for more than 5 seconds.

Auto idle will become **active** if ALL of the following are true:

1. Engine is running.
2. It has been more than 30 seconds since engine start.
3. Park brake is released.
4. Engine speed control dial or engine speed control pedal is more than 5% above idle.
5. Auxiliary hydraulics are not enabled.
6. Left and right joysticks are in center position.
7. No travel, boom, or bucket functions have been activated.
8. Items 1—7 have been true for longer than 5 seconds.

NOTE: AUTO IDLE will be displayed on the EMU when machine is in auto idle mode.

To deactivate auto idle, do any of the following:

- Adjusting engine speed control dial by more than 5%.
- If engine speed control dial is not at maximum, moving engine speed control pedal by more than 5%.
- Move either left or right joystick out of neutral position.
- Actuate auxiliary proportional switch.

NOTE: Auto idle is also deactivated if engine is shut off.

OUT4001,0000537 -19-12NOV09-1/1

Boom and Bucket Speed Settings—If Equipped

For EH machines with performance package only, one of three boom and bucket speed rate settings can be selected for increased performance and to suit desired operator preference.

Press MENU button on the engagement and monitor unit (EMU). Boom and Bucket Rate will be the first screen to appear. Press SELECT button. Cycle through rates using the NEXT button. Rates will appear in the following order:

- **Production Rate Selected**
(Normal operating mode) - Provides fast response to the joystick command. All functions attain 100% maximum speed for each function.

- **Utility Rate Selected**
(Medium speed) - Provides slower response to the joystick command. All functions attain 100% maximum speed at the end of joystick travel. This setting is the default setting from the factory.
- **Precision Rate Selected**
(Slowest mode) - Provides slowest response to the joystick command. Speed is limited to no less than 80%.

When desired rate appears on the screen, press SELECT button to set that rate and screen will return to Main Menu. Press MENU button to return to normal run-time display.

OUT4001,0000538 -19-10NOV09-1/1

Loading Machine On a Trailer

IMPORTANT: Avoid damage. Never put chains across bucket cylinders. Damage to cylinders may occur.

Do not tow machine or hydrostatic system damage may occur.

NOTE: Use extra caution in wet or muddy conditions.

1. Use a heavy-duty trailer to transport machine.
2. Park trailer on firm, level ground.
3. Keep trailer bed clean.
4. Place chock blocks (1) against the trailer wheels.
5. Back machine onto trailer keeping boom and/or attachment low.
6. Centerline of machine should be over centerline of trailer.
7. Before exiting machine, lower attachment to trailer bed, engage park brake, and shut engine OFF.
8. Fasten machine securely to trailer with heavy-duty straps, chains, or cables using tie downs (2) in front and in rear of machine. Both front and rear straps must be directed down and outward from machine.
9. Trailer must have signs and lights required by law.

1— Chock Block

2— Tie Down (4 used)

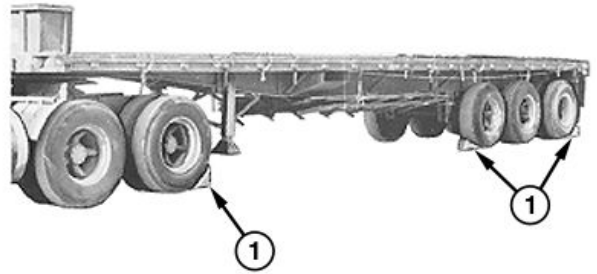

Loading Machine on a Trailer

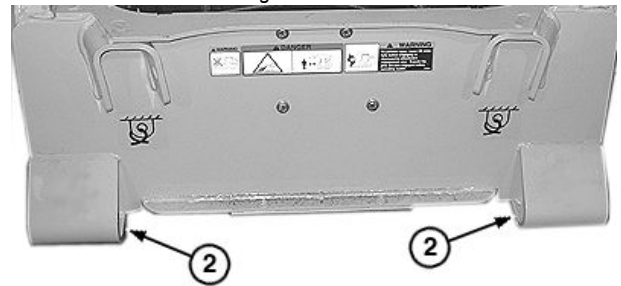

Front of Machine Shown—Boom Raised For Picture Clarity

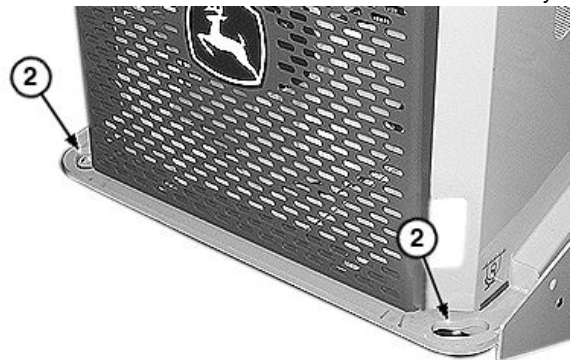

Rear of Machine Shown

OUT4001,0000539 -19-23OCT12-1/1

TX1010855A—UN—03AUG06

TX1067198A—UN—12NOV09

TX1067199A—UN—12NOV09

Operation—Track Information

Undercarriage Component Identification

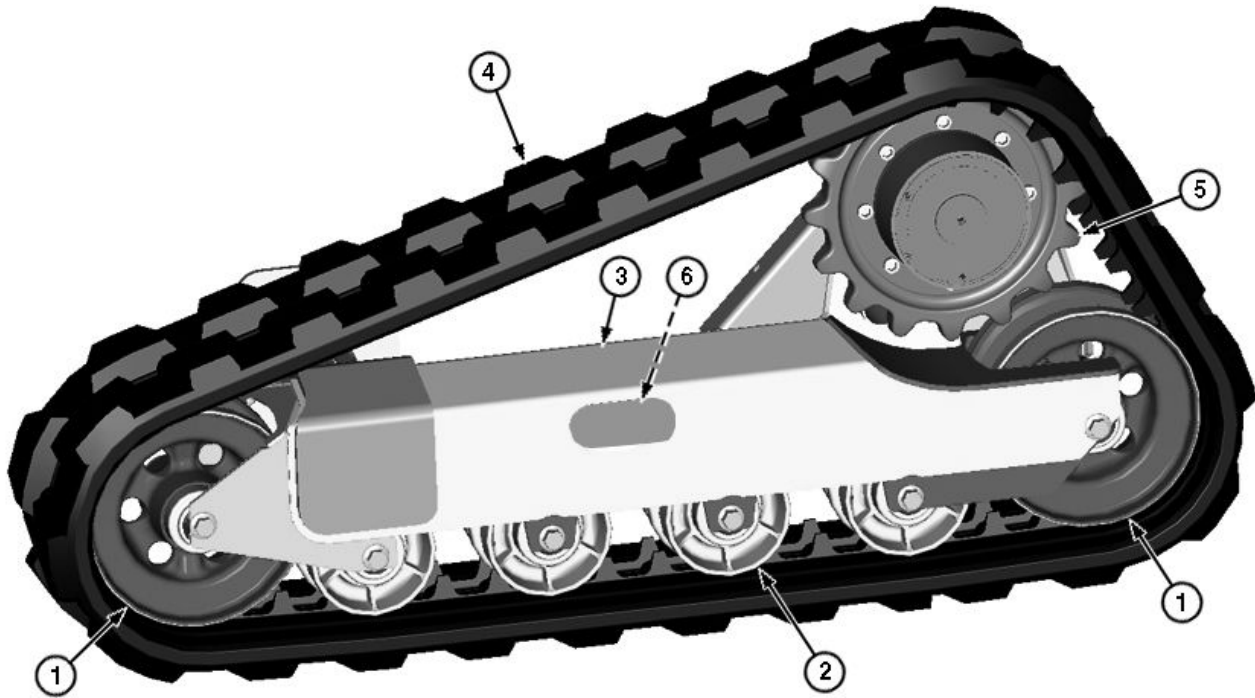

Undercarriage

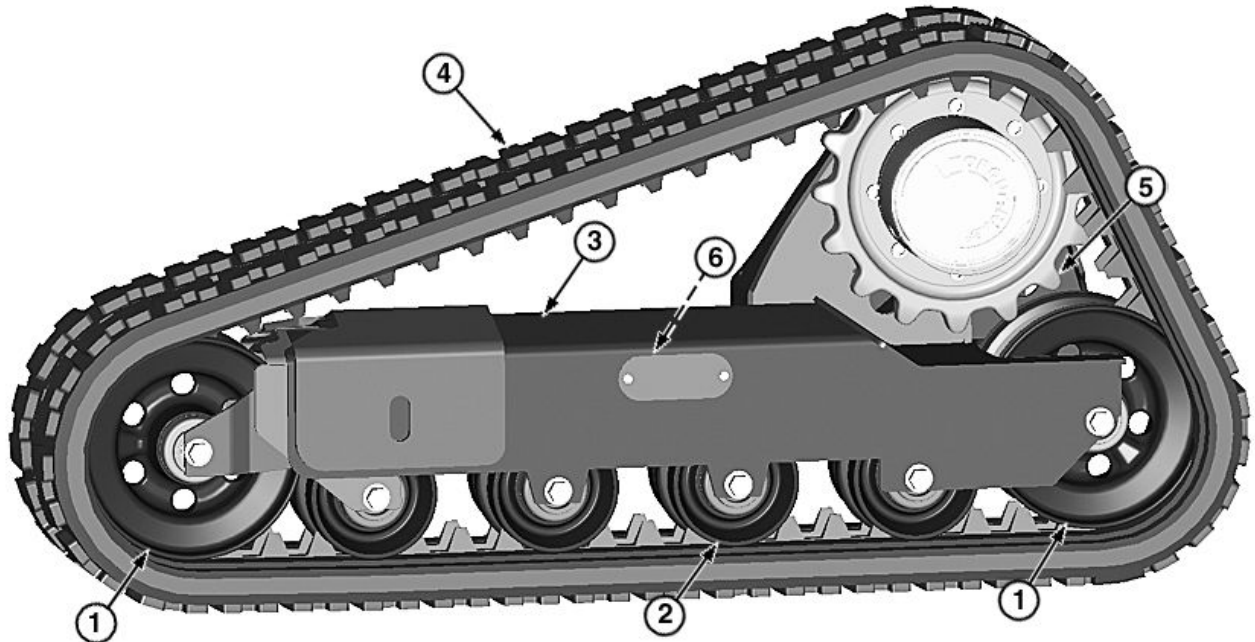

Undercarriage

1— Idler (2 per side)
2— Roller (4 per side)

3— Undercarriage Frame
4— Track

5— Drive Sprocket
6— Track Adjuster Grease Fitting

TX1064637A—UN—30OCT09

TX1081193A—UN—24AUG10

Continued on next page

ER79617,0000C2F -19-04OCT12-1/2

Proper machine setup and operation are important to extend the life of the track system components. By following the recommendations in this section, the

operator can reduce unplanned downtime, maximize operator efficiency, and minimize operating costs.

ER79617,0000C2F -19-04OCT12-2/2

Rubber Track Structure

- 1— Rubber Casing
- 2— Guide Lug
- 3— Embedded Metal Insert
- 4— Steel Cord
- 5— Tread Lug

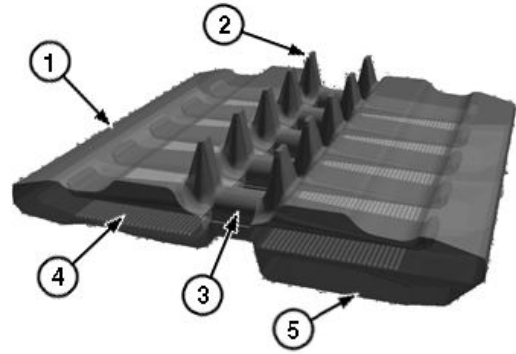

Rubber Track Structure

OUT4001,000049A -19-22SEP09-1/1

TX1021372—UN—03MAY07

Rubber Track Usage

Damage to rubber tracks caused from operating the machine in unsuitable environments (such as rocky terrain, asphalt, concrete, metal debris, etc.) may cause premature wear of the rubber tracks and is not covered under warranty. The more care an operator takes when using rubber tracked equipment, the longer the track will perform as expected.

AVOID:

1. Constant operation across a slope or side hill. This will cause accelerated, uneven wear of undercarriage components. Unless the job requires otherwise, climb slopes straight up and down.
2. Making spin turns or pivot turns. This will cause accelerated wear and increase the potential for de-tracking. Operators should be trained to make wider, less aggressive turns especially on hard surfaces.
3. Traveling with one track on a slope, and the other on a flat surface. Travel with both tracks on level surfaces when possible.
4. Running over curbs or along curbs and other structures allowing tracks to rub against the structure.
5. Traveling or operating rubber track units on broken stone, jagged base stone, iron rods, scrap iron, or other recycling-type materials.
6. Continuous transporting and aggressive turning on hard surfaces such as asphalt and concrete.
7. Operating in corrosive materials (fuel, oil, salt, fertilizer, etc.). Clean the tracks and undercarriage with clear water if any substances get on the tracks.

DO:

1. Monitor track sag on a weekly basis or as needed. Certain soil conditions may require additional adjustments. Loose tracks can wander and de-track; however, be careful not to over-tighten. Over-tightening may cause power loss and excessive wear of undercarriage components. See Adjust Track Sag. (Section 3-5.)
2. Clean out the undercarriage, especially at the end of the work day in cold temperatures to prevent material from freezing and putting excessive loads on the operating systems.
3. Minimize the spinning of tracks when possible.

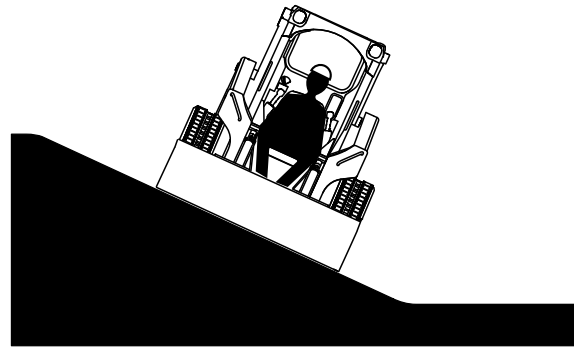

Constant Operation Across a Slope

TX1064891 —UN—02OCT09

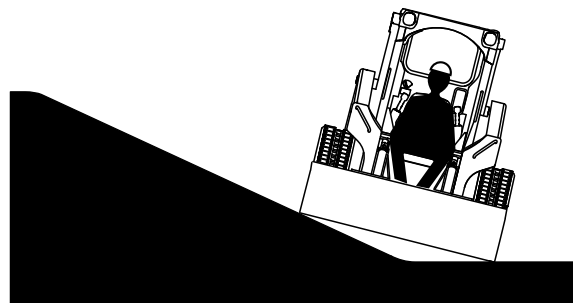

One Track on Slope

TX1064892 —UN—02OCT09

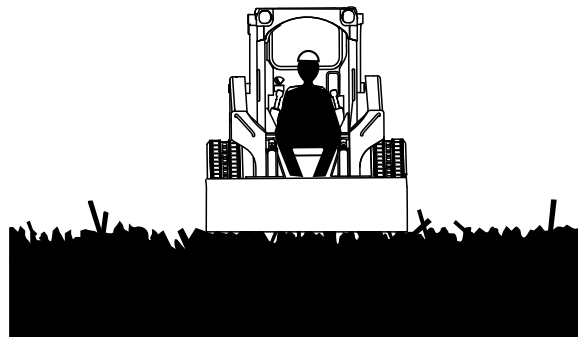

Jagged Surface

TX1064893 —UN—02OCT09

4. Alternate turning direction. Continuous turning in the same direction can create an accelerated wear pattern on undercarriage components.

OUT4001,000049C -19-22OCT09-1/1

Sprocket Teeth Wear

Under sandy conditions, teeth can wear faster. The embedded metal inserts will wear a pocket into the sprocket. Check for wear on the top of sprocket teeth (1).

1— Top of Sprocket Teeth

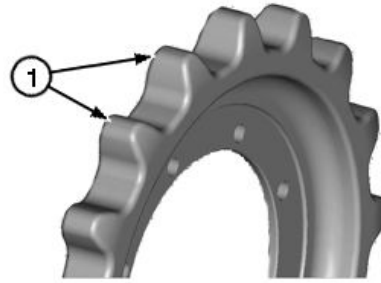

Sprocket Teeth Wear

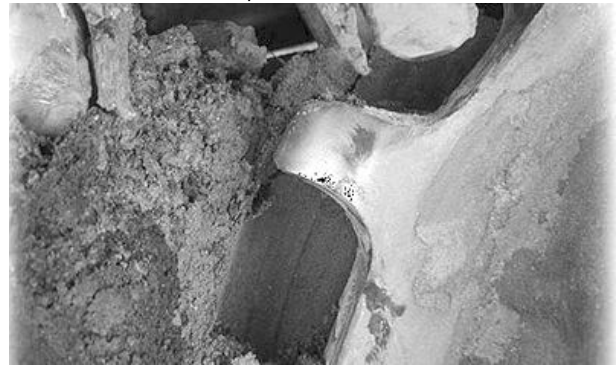

Sprocket Tooth Profile Wear

OUT4001,00004A0 -19-06DEC12-1/1

TX1021373 —UN—01MAY07

TX1021390A —UN—30MAR07

Normal Break-In

In these examples of normal wear, the rubber has been removed by friction to expose the metal on the guide lugs.

The guide lugs have a very light coating of rubber over them that will wear off quickly.

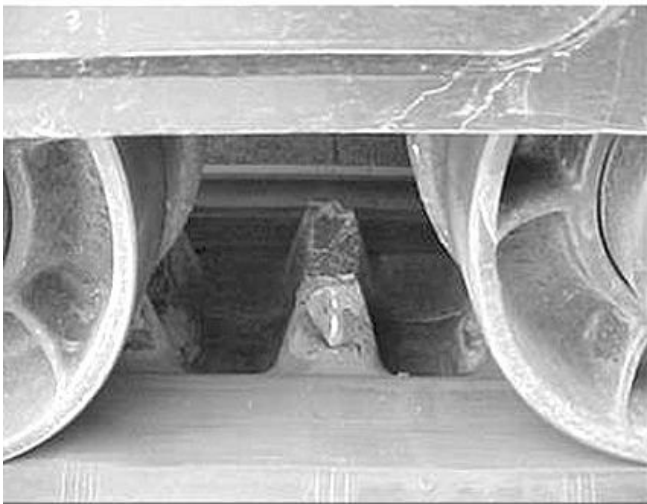

Examples of Normal Break-In

TX1021391A —UN—30MAR07

OUT4001.000049E -19-21SEP09-1/1

Normal Track Wear in Dirt Conditions

In dirt conditions, tracks will show wear lines (small cracks) but will not have rubber chunks being removed.

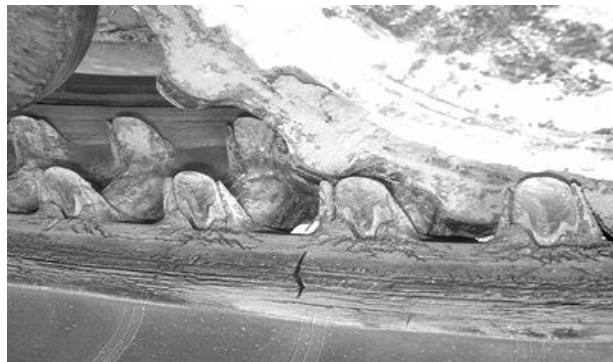

Normal Track Wear in Dirt Conditions

TX1021570A —UN—04APR07

OUT4001.00004A2 -19-22OCT12-1/1

Rubber Track—Types of Damage

Cut on Tread Lug Side Rubber

Cut on tread lug side rubber often occurs as one of the most typical failure modes. It is most likely caused by counter rotating on hard sharp material or by driving over a hard sharp object.

When a cut on the lug side rubber reaches the embedded steel cord, cords can rapidly corrode due to foreign material entry and can cause premature failure of the track.



Counter Rotating Damage



Driving Over Sharp Object

TX1021393A —UN—30MAR07

TX1021394A —UN—30MAR07

OUT4001,00004A1 -19-06DEC12-1/7

Crack on Tread Lug Side Rubber—Fatigue

Small cracks occur as a result of operation fatigue or long term environmental damage such as sun or chemicals.

When the cracks reach so deep that they expose the steel cords, premature failure can occur.



Fatigue

TX1021403A —UN—30MAR07

Continued on next page

OUT4001,00004A1 -19-06DEC12-2/7

Cuts on the Edges of the Track Roller Side Rubber

Edge (1) cuts indicate normal wear which can be caused by hitting rocks, sticks, or other sharp objects. It is unusual for this type of damage to occur on soft ground or small gravel. As long as the cut does not enter the cords or metal, no action is necessary.

1— Edge

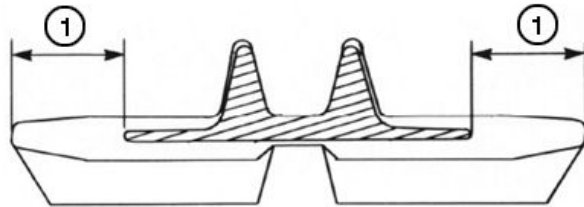

Edge of Track Roller

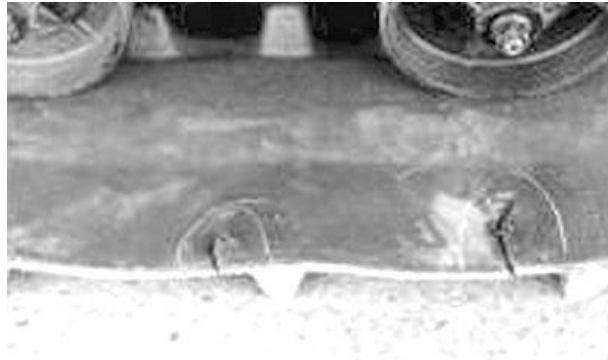

Cuts on the Edges of the Track Roller Side Rubber

OUT4001,00004A1 -19-06DEC12-3/7

TX1021375 —UN—01MAY07

TX1021407A —UN—30MAR07

Tread Lug Abrasion

Lug abrasion is normal and the track can be replaced when the lug height becomes less than 5 mm (0.2 in.). Running on hard surfaces such as pavement can decrease track life significantly. Owner can run the track until smooth, if required.



Tread Lug Abrasion

Continued on next page

OUT4001,00004A1 -19-06DEC12-4/7

TX1021408A —UN—30MAR07

Deterioration of the Track Roller Side Rubber Surface

In normal applications with gravel, the rubber surface will wear down until the metal is exposed. It is recommended to replace the rubber track when more than half of the embedded metals are completely exposed.

In normal soil conditions, the inside rubber will wear but not chunk out the rubber. The ride will become rough as the rubber wears down.

When running in a heavy rock condition, cuts in the rubber can cause the rubber to come out in chunks. The embedded metal will become exposed.

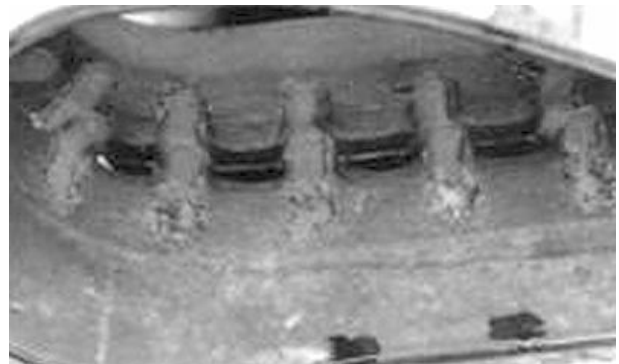

Track Roller



Results of Running in Heavy Rock Condition

OUT4001,00004A1 -19-06DEC12-5/7

TX1021415A —UN—30MAR07

TX1021563A —UN—04APR07

Separation of Metal Inserts—External Forces and Corrosion

Metal inserts should not separate from the track unless there is abuse of the track or it is operated in a corrosive environment. The metal insert will separate at the end of the track's life span. It is suggested that even partial separation or corrosion can cause a need to replace the complete track.

Foreign material entering the track system such as reinforcing rod from concrete or sharp rock can cause this type of damage.

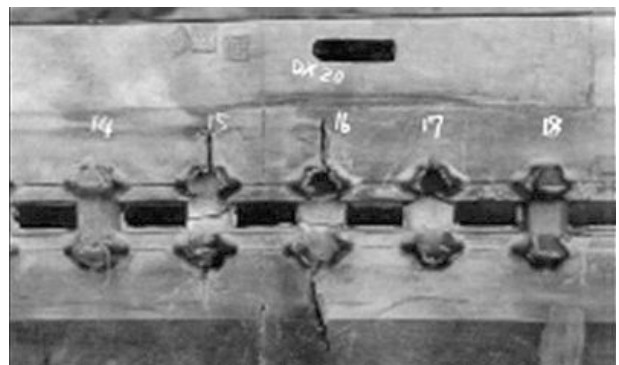

Separation of Metal Inserts

Continued on next page

OUT4001,00004A1 -19-06DEC12-6/7

TX1021566A —UN—04APR07

TX1021567A —UN—04APR07

Cut Steel Cord

If embedded steel cords are cut off, replacement is required. Heavy damage may be caused by a sharp edge and possibly counter rotating on the sharp edge.



Cut Steel Cord

TX1021568A —JN—04APR07

OUT4001,00004A1 -19-06DEC12-7/7

Maintenance—Machine

Diesel Fuel

Consult your local fuel distributor for properties of the diesel fuel available in your area.

In general, diesel fuels are blended to satisfy the low temperature requirements of the geographical area in which they are marketed.

Diesel fuels specified to EN 590 or ASTM D975 are recommended. Renewable diesel fuel produced by hydrotreating animal fats and vegetable oils is basically identical to petroleum diesel fuel. Renewable diesel that meets EN 590 or ASTM D975 is acceptable for use at all percentage mixture levels.

Required Fuel Properties

In all cases, the fuel shall meet the following properties:

Cetane number of 43 minimum. Cetane number greater than 47 is preferred, especially for temperatures below -20°C (-4°F) or elevations above 1500 m (5000 ft.).

Cold Filter Plugging Point (CFPP) should be at least 5°C (9°F) below the expected lowest temperature or **Cloud Point** below the expected lowest ambient temperature.

Fuel lubricity should pass a maximum scar diameter of 0.45 mm as measured by ASTM D6079 or ISO 12156-1.

Diesel fuel quality and sulfur content must comply with all existing emissions regulations for the area in which the engine operates. **DO NOT** use diesel fuel with sulfur content greater than 10 000 mg/kg (10 000 ppm).

Sulfur content for Interim Tier 4 and Stage III B engines

- Use **ONLY** ultra low sulfur diesel (ULSD) fuel with a maximum of 15 mg/kg (15 ppm) sulfur content.

Sulfur Content for Tier 3 and Stage III A Engines

- Use of diesel fuel with sulfur content less than 1000 mg/kg (1000 ppm) is **RECOMMENDED**
- Use of diesel fuel with sulfur content 1000–5000 mg/kg (1000–5000 ppm) **REDUCES** oil and filter change intervals.
- **BEFORE** using diesel fuel with sulfur content greater than 5000 mg/kg (5000 ppm), contact your John Deere dealer

Sulfur Content for Tier 2 and Stage II Engines

- Use of diesel fuel with sulfur content less than 500 mg/kg (500 ppm) is **RECOMMENDED**.
- Use of diesel fuel with sulfur content 500–5000 mg/kg (500–5000 ppm) **REDUCES** the oil and filter change interval
- **BEFORE** using diesel fuel with sulfur content greater than 5000 mg/kg (5000 ppm), contact your John Deere dealer

Sulfur Content for Other Engines

- Use of diesel fuel with sulfur content less than 5000 mg/kg (5000 ppm) is recommended.
- Use of diesel fuel with sulfur content greater than 5000 mg/kg (5000 ppm) **REDUCES** the oil and filter change intervals.

IMPORTANT: Do not mix used diesel engine oil or any other type of lubricating oil with diesel fuel.

IMPORTANT: Improper fuel additive usage may cause damage on fuel injection equipment of diesel engines.

DX,FUEL1 -19-11APR11-1/1

Lubricity of Diesel Fuel

Most diesel fuels manufactured in the United States, Canada, and the European Union have adequate lubricity to ensure proper operation and durability of fuel injection system components. However, diesel fuels manufactured in some areas of the world may lack the necessary lubricity.

IMPORTANT: Make sure the diesel fuel used in your machine demonstrates good lubricity characteristics.

Fuel lubricity should pass a maximum scar diameter of 0.45 mm as measured by ASTM D6079 or ISO 12156-1.

If fuel of low or unknown lubricity is used, add John Deere Fuel-Protect Diesel Fuel Conditioner (or equivalent) at the specified concentration.

Lubricity of Biodiesel Fuel

Fuel lubricity can improve significantly with biodiesel blends up to B20 (20% biodiesel). Further increase in lubricity is limited for biodiesel blends greater than B20.

DX,FUEL5 -19-14APR11-1/1

Handling and Storing Diesel Fuel

⚠ CAUTION: Reduce the risk of fire. Handle fuel carefully. DO NOT fill the fuel tank when engine is running. DO NOT smoke while you fill the fuel tank or service the fuel system.

Fill the fuel tank at the end of each day's operation to prevent water condensation and freezing during cold weather.

Keep all storage tanks as full as practicable to minimize condensation.

Ensure that all fuel tank caps and covers are installed properly to prevent moisture from entering. Monitor water content of the fuel regularly.

When using biodiesel fuel, the fuel filter may require more frequent replacement due to premature plugging.

Check engine oil level daily prior to starting engine. A rising oil level may indicate fuel dilution of the engine oil.

IMPORTANT: The fuel tank is vented through the filler cap. If a new filler cap is required, always replace it with an original vented cap.

When fuel is stored for an extended period or if there is a slow turnover of fuel, add a fuel conditioner to stabilize the fuel and prevent water condensation. Contact your fuel supplier for recommendations.

DX,FUEL4 -19-14APR11-1/1

Biodiesel Fuel

Biodiesel fuel is comprised of mono-alkyl esters of long chain fatty acids derived from vegetable oils or animal fats. Biodiesel blends are biodiesel mixed with petroleum diesel fuel on a volume basis.

Before using fuel containing biodiesel, review the Biodiesel Use Requirements and Recommendations in this Operator's Manual.

Environmental laws and regulations can encourage or prohibit the use of biofuels. Operators should consult with appropriate governmental authorities prior to using biofuels.

All John Deere Engines with Exhaust Filter (Released 2011 and After)

While 5% blends (B5) are preferred, biodiesel concentrations up to a 20% blend (B20) in petroleum diesel fuel can be used. Biodiesel blends up to B20 can be used ONLY if the biodiesel (100% biodiesel or B100) meets ASTM D6751, EN 14214, or equivalent specification. Expect a 2% reduction in power and a 3% reduction in fuel economy when using B20.

Biodiesel concentrations above B20 can harm the engine's emission control systems and should not be used. Risks include, but are not limited to, more frequent stationary regeneration, soot accumulation, and increased intervals for ash removal.

John Deere approved fuel conditioners, which contain detergent and dispersant additives, are required when using B20, and are recommended when using lower biodiesel blends.

All John Deere Engines Excluding Exhaust Filter (Primarily Released Prior to 2012)

While 5% blends (B5) are preferred, biodiesel concentrations up to a 20% blend (B20) in petroleum diesel fuel can be used. Biodiesel blends up to B20 can be used ONLY if the biodiesel (100% biodiesel or B100) meets ASTM D6751, EN 14214, or equivalent specification. Expect a 2% reduction in power and a 3% reduction in fuel economy when using B20.

These John Deere engines can operate on biodiesel blends above B20 (up to 100% biodiesel). Operate at levels above B20 ONLY if the biodiesel is permitted by law and meets the EN 14214 specification (primarily available in Europe). Engines operating on biodiesel blends above B20 might not fully comply with or be permitted by all applicable emissions regulations. Expect up to a 12% reduction in power and an 18% reduction in fuel economy when using 100% biodiesel.

John Deere approved fuel conditioners, which contain detergent and dispersant additives, are required when using B20, and are recommended when using lower biodiesel blends.

Biodiesel Use Requirements and Recommendations

The petroleum diesel portion of all biodiesel blends must meet the requirements of ASTM D975 (US) or EN 590 (EU) commercial standards.

Biodiesel users in the U.S. are strongly encouraged to purchase biodiesel blends from a BQ-9000 Certified Marketer and sourced from a BQ-9000 Accredited Producer (as certified by the National Biodiesel Board). Certified Marketers and Accredited Producers can be found at the following website: <http://www.bq9000.org>.

Biodiesel contains residual ash. Ash levels exceeding the maximums allowed in either ASTM D6751 or EN14214 can result in more rapid ash loading and require more frequent cleaning of the Exhaust Filter (if present).

The fuel filter can require more frequent replacement, when using biodiesel fuel, particularly if switching from diesel. Check engine oil level daily prior to starting engine. A rising oil level can indicate fuel dilution of the engine oil. Biodiesel blends up to B20 must be used within 90 days of the date of biodiesel manufacture. If used, biodiesel blends above B20 must be used within 45 days from the date of biodiesel manufacture.

When using biodiesel blends up to B20, the following must be considered:

- Cold weather flow degradation
- Stability and storage issues (moisture absorption, microbial growth)
- Possible filter restriction and plugging (usually a problem when first switching to biodiesel on used engines.)
- Possible fuel leakage through seals and hoses (primarily an issue with older engines)
- Possible reduction of service life of engine components

Request a certificate of analysis from your fuel distributor to ensure that the fuel is compliant with the specifications provided in this Operator's Manual.

Consult your John Deere dealer for approved fuel conditioners to improve storage and performance with biodiesel fuels.

The following must also be considered if using biodiesel blends above B20:

- Possible coking or blocked injector nozzles, resulting in power loss and engine misfire if John Deere approved fuel conditioners are not used
- Possible crankcase oil dilution (requiring more frequent oil changes)
- Possible lacquering or seizure of internal components
- Possible formation of sludge and sediments
- Possible thermal oxidation of fuel at elevated temperatures
- Possible compatibility issues with other materials (including copper, lead, zinc, tin, brass, and bronze) used in fuel handling equipment
- Possible reduction in water separator efficiency
- Possible damage to paint if exposed to biodiesel

Continued on next page

DX,FUEL7 -19-29AUG12-1/2

- Possible corrosion of fuel injection equipment
- Possible elastomeric seal and gasket material degradation (primarily an issue with older engines)
- Possible high acid levels within fuel system
- Because biodiesel blends above B20 contain more ash, using blends above B20 can result in more rapid ash loading and require more frequent cleaning of the Exhaust Filter (if present)

IMPORTANT: Raw pressed vegetable oils are NOT acceptable for use as fuel in any concentration in John Deere engines. Their use could cause engine failure.

DX,FUEL7 -19-29AUG12-2/2

Testing Diesel Fuel

A fuel analysis program can help to monitor the quality of diesel fuel. The fuel analysis can provide critical data such as cetane number, fuel type, sulfur content, water content, appearance, suitability for cold weather

operations, bacteria, cloud point, acid number, particulate contamination, and whether the fuel meets specification.

Contact your John Deere dealer for more information on diesel fuel analysis.

DX,FUEL6 -19-14APR11-1/1

Minimizing the Effect of Cold Weather on Diesel Engines

John Deere diesel engines are designed to operate effectively in cold weather.

However, for effective starting and cold-weather operation, a little extra care is necessary. The following information outlines steps that can minimize the effect that cold weather may have on starting and operation of your engine. See your John Deere dealer for additional information and local availability of cold-weather aids.

Use Winter Grade Fuel

When temperatures fall below 0°C (32°F), winter grade fuel (No. 1-D in North America) is best suited for cold-weather operation. Winter grade fuel has a lower cloud point and a lower pour point.

Cloud point is the temperature at which wax will begin to form in the fuel and this wax causes fuel filters to plug.

Pour point is the lowest temperature at which movement of the fuel is observed.

NOTE: On an average, winter grade diesel fuel has a lower BTU (heat content) rating. Using winter grade fuel may reduce power and fuel efficiency, but should not cause any other engine performance effects. Check the grade of fuel being used before troubleshooting for low-power complaints in cold-weather operation.

CAUTION: Ether is highly flammable. Do not use ether when starting an engine equipped with glow plugs.

Coolant Heater

An engine block heater (coolant heater) is an available option to aid cold weather starting.

Seasonal Viscosity Oil and Proper Coolant Concentration

Use seasonal grade viscosity engine oil based on the expected air temperature range between oil changes and a proper concentration of low silicate antifreeze as recommended. (See DIESEL ENGINE OIL and ENGINE COOLANT requirements in this section.)

Diesel Fuel Flow Additive

Use John Deere PREMIUM DIESEL FUEL CONDITIONER (winter formula), which contains anti-gel chemistry, or equivalent fuel conditioner to treat non-winter

grade fuel (No. 2-D in North America) during the cold-weather season. This generally extends operability to about 10°C (18°F) below the fuel cloud point. For operability at even lower temperatures, use winter grade fuel.

IMPORTANT: Treat fuel when outside temperature drops below 0°C (32°F). For best results, use with untreated fuel. Follow all recommended instructions on label.

BioDiesel

When operating with biodiesel blends, wax formation can occur at warmer temperatures. Begin using John Deere PREMIUM BIODIESEL FUEL CONDITIONER (winter formula) at 5°C (41°F) to treat biodiesel fuels during the cold-weather season. Use B5 or lower blends at temperatures below 0°C (32°F). Use only winter grade petroleum diesel fuel at temperatures below -10°C (14°F).

Winterfronts

Use of fabric, cardboard, or solid winterfronts is not recommended with any John Deere engine. Their use can result in excessive engine coolant, oil, and charge air temperatures. This can lead to reduced engine life, loss of power and poor fuel economy. Winterfronts may also put abnormal stress on fan and fan drive components potentially causing premature failures.

If winterfronts are used, they should never totally close off the grill frontal area. Approximately 25% area in the center of the grill should remain open at all times. At no time should the air blockage device be applied directly to the radiator core.

Radiator Shutters

If equipped with a thermostatically controlled radiator shutter system, this system should be regulated in such a way that the shutters are completely open by the time the coolant reaches 93°C (200°F) to prevent excessive intake manifold temperatures. Manually controlled systems are not recommended.

If air-to-air aftercooling is used, the shutters must be completely open by the time the intake manifold air temperature reaches the maximum allowable temperature out of the charge air cooler.

For more information, see your John Deere dealer.

OUT4001,000053D -19-24MAR10-1/1

Operating in Cold Temperature Climates

The following oils are recommended for optimum starting performance:

- Engine Oil SAE 0W-40
- Hydraulic Oil SAE 0W-40

(S.N. —214397)

Machines were shipped from the factory with 10W-30 engine oil in the engine and hydraulic reservoir.

(S.N. 214398—)

Machines are shipped from the factory with 0W-40 engine oil in the engine.

Machines equipped with the optional cold start package are shipped from the factory with 0W-40 engine oil in the hydraulic reservoir and machines without the cold start package are filled with 10W-30.

MB60223,000023F -19-21NOV11-1/1

Alternative and Synthetic Lubricants

Conditions in certain geographical areas may require lubricant recommendations different from those printed in this manual.

Some John Deere brand coolants and lubricants may not be available in your location.

Consult your John Deere dealer to obtain information and recommendations.

Synthetic lubricants may be used if they meet the performance requirements as shown in this manual.

The temperature limits and service intervals shown in this manual apply to both conventional and synthetic lubricants.

Re-refined base stock products may be used if the finished lubricant meets the performance requirements.

DX,ALTER -19-11APR11-1/1

Diesel Engine Break-In Oil

IMPORTANT: Avoid engine damage. DO NOT use break-in oil in this engine.

See Diesel Engine Oil in this section.

OUT4001,0000523 -19-29OCT09-1/1

Diesel Engine Oil—Interim Tier 4 and Stage III B Engines

Use oil viscosity based on the expected air temperature range during the period between oil changes.

John Deere Plus-50™ II is the recommended engine oil.

Extended service intervals may apply when John Deere Plus-50 II engine oil is used. Refer to the engine oil drain interval table and consult your John Deere dealer for more information.

If John Deere Plus-50 II engine oil is not available, engine oil meeting one or more of the following may be used:

- API Service Category CJ-4
- ACEA Oil Sequence E9
- ACEA Oil Sequence E6

DO NOT use engine oil containing more than 1.0% sulfated ash, 0.12% phosphorus, or 0.4% sulfur.

Multi-viscosity diesel engine oils are preferred.

Diesel fuel quality and fuel sulfur content must comply with all existing emissions regulations for the area in which the engine operates.

IMPORTANT: Use only ultra low sulfur diesel (ULSD) fuel with a maximum sulfur content of 15 mg/kg (15 ppm).

Plus-50 is a trademark of Deere & Company

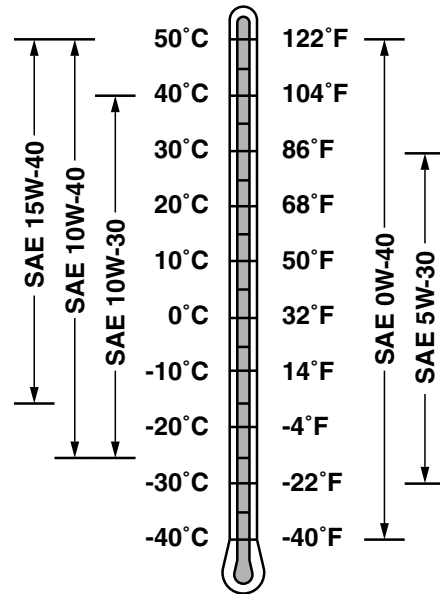

Oil Viscosities for Air Temperature Ranges

TX1114353 —UN—22MAY12

VD76477,00004E6 -19-23MAY12-1/1

Engine Oil and Filter Service Intervals—Interim Tier 4 and Stage III B Engines

Recommended oil and filter service intervals are based on a combination of oil pan capacity, type of engine oil and filter used, and sulfur content of the diesel fuel. Actual service intervals also depend on operation and maintenance practices.

Use oil analysis to evaluate the condition of the oil and to aid in selection of the proper oil and filter service interval. Contact your John Deere dealer for more information on engine oil analysis.

Change the oil and oil filter at least once every 12 months even if the hours of operation are fewer than the otherwise recommended service interval.

Diesel fuel sulfur content affects engine oil and filter service intervals. Higher fuel sulfur levels reduce oil and filter service intervals.

Use of diesel fuel with sulfur content less than 15 mg/kg (15 ppm) is **REQUIRED**.

IMPORTANT: To avoid engine damage:

- Reduce oil and filter service intervals by 50% when using biodiesel blends greater than B20. Oil analysis may allow longer service intervals.
- Use only approved oil types.

Approved Oil Types:

- John Deere Plus-50™ II.
- “Other Oils” include API CJ-4, ACEA E9, and ACEA E6.

NOTE: The 500 hour extended oil and filter change interval is only allowed if all of the following conditions are met:

- Use of diesel fuel with sulfur content less than 15 mg/kg (15 ppm).
- Use of John Deere Plus-50™ II oil.
- Use of an approved John Deere oil filter.

Engine Oil and Filter Service Intervals	
John Deere Plus-50™ II	500 hours
Other Oils	250 hours

Plus-50 is a trademark of Deere & Company

DX,ENOIL15,IT4,120toMAX -19-14APR11-1/1

Light Duty Diesel Engine Coolant (for diesel engines without wet sleeve cylinder liners)

The engine cooling system is filled to provide year-round protection against corrosion and cylinder liner pitting, and winter freeze protection to -37°C (-34°F). If protection at lower temperatures is required, consult your John Deere dealer for recommendations.

The following engine coolants are preferred:

- John Deere COOL-GARD™ II Premix
- John Deere COOL-GARD II PG Premix

Use John Deere COOL-GARD™ II PG Premix when a non-toxic coolant formulation is required.

Additional Recommended Coolants

The following engine coolant is also recommended:

- John Deere COOL-GARD II Concentrate in a 40—60% mixture of concentrate with quality water.

Other Coolants

Other ethylene glycol or propylene glycol base coolants may be used if they meet one of the following specifications:

- ASTM D3306 prediluted (50%) coolant
- ASTM D3306 coolant concentrate in a 40—60% mixture of concentrate with quality water

If these coolants are unavailable, use an engine coolant concentrate or prediluted coolant with a minimum of the following chemical and physical properties:

- Is formulated with a quality nitrite-free additive package.

COOL-GARD is a trademark of Deere & Company

- Protects the cooling system metals (cast iron, aluminum alloys, and copper alloys such as brass) from corrosion.

The coolant concentrate or prediluted coolant shall be of a quality that is suitable for all-aluminum engines.

Water Quality

Water quality is important to the performance of the cooling system. Distilled, deionized, or demineralized water is recommended for mixing with ethylene glycol base engine coolant concentrate.

Coolant Drain Intervals

Drain and flush the cooling system and refill with fresh coolant at the indicated interval, which varies with the coolant used.

When John Deere COOL-GARD II is used, the drain interval is six years or 6000 hours of operation.

When John Deere COOL-GARD II PG is used, the drain interval is five years or 5000 hours of operation.

If a coolant other than COOL-GARD II or COOL-GARD II PG is used, reduce the drain interval to two years or 2000 hours of operation.

IMPORTANT: Do not use cooling system sealing additives or antifreeze that contains sealing additives.

Do not mix ethylene glycol and propylene glycol base coolants.

DX,COOL18 -19-20APR11-1/1

Drain Intervals for Diesel Engine Coolant

Drain and flush the cooling system and refill with fresh coolant at the indicated interval, which varies with the coolant used.

John Deere COOL-GARD™ II Premix, COOL-GARD II PG Premix and COOL-GARD II Concentrate are maintenance free coolants for up to six years or 6000 hours of operation, provided that the cooling system is topped off using only John Deere COOL-GARD II Premix or COOL-GARD II PG Premix.

Test the coolant condition annually with Coolant Test Strips designed for use with John Deere COOL-GARD II coolants. If the test strip chart indicates that additive is required, add John Deere COOL-GARD II Coolant Extender as directed.

COOL-GARD is a trademark of Deere & Company

If John Deere COOL-GARD™ II Premix, COOL-GARD II PG Premix, or COOL-GARD II Concentrate is used, but the coolant is not tested OR additives are not replenished by adding John Deere COOL-GARD II Coolant Extender, the drain interval is four years or 4000 hours of operation. This drain interval only applies to COOL-GARD II coolants that have been maintained within a 40—60% mixture of concentrate with quality water.

If a coolant other than COOL-GARD II, or COOL-GARD II PG is used, reduce the drain interval to two years or 2000 hours of operation.

DX,COOL11 -19-14APR11-1/1

John Deere COOL-GARD™ II Coolant Extender

Some coolant additives will gradually deplete during engine operation. For John Deere COOL-GARD™ II Premix, COOL-GARD II PG Premix, and COOL-GARD II Concentrate, replenish coolant additives between drain intervals by adding John Deere COOL-GARD II Coolant Extender.

John Deere COOL-GARD II Coolant Extender should not be added unless indicated by coolant testing.

John Deere COOL-GARD II Coolant Extender is a chemically matched additive system for use with all John Deere COOL-GARD II coolants. John Deere COOL-GARD II Coolant Extender is not intended for use with nitrite-containing coolants.

COOL-GARD is a trademark of Deere & Company

IMPORTANT: Do not add a supplemental coolant additive when the cooling system is drained and refilled with any of the following:

- John Deere COOL-GARD II
- John Deere COOL-GARD II PG

The use of non-recommended supplemental coolant additives may result in additive drop-out, gelation of the coolant, or corrosion of cooling system components.

Add the recommended concentration of John Deere COOL-GARD II Coolant Extender. DO NOT add more than the recommended amount.

DX,COOL16 -19-20APR11-1/1

Supplemental Coolant Additives

Some coolant additives will gradually deplete during engine operation. For nitrite-containing coolants, replenish coolant additives between drain intervals by adding a supplemental coolant additive as determined necessary by coolant testing.

John Deere Liquid Coolant Conditioner is recommended as a supplemental coolant additive for nitrite-containing coolants.

John Deere Liquid Coolant Conditioner is not designed for use with John Deere COOL-GARD™ II Premix, COOL-GARD II PG Premix, or COOL-GARD II Concentrate.

IMPORTANT: Do not add a supplemental coolant additive when the cooling system is drained and refilled with any of the following:

COOL-GARD is a trademark of Deere & Company

- John Deere COOL-GARD II
- John Deere COOL-GARD II PG

If other coolants are used, consult the coolant supplier and follow the manufacturer's recommendation for use of supplemental coolant additives.

The use of non-recommended supplemental coolant additives may result in additive drop-out and gelation of the coolant.

Add the manufacturer's recommended concentration of supplemental coolant additive. DO NOT add more than the recommended amount.

DX,COOL4 -19-14APR11-1/1

Operating in Warm Temperature Climates

John Deere engines are designed to operate using glycol base engine coolants.

Always use a recommended glycol base engine coolant, even when operating in geographical areas where freeze protection is not required.

John Deere COOL-GARD™ II Premix is available in a concentration of 50% ethylene glycol. However, there are situations in warm temperature climates where a coolant with lower glycol concentration (approximately 20% ethylene glycol) has been approved. In these cases, the low glycol formulation has been modified to provide the same level of corrosion inhibitor as John Deere COOL-GARD II Premix (50/50).

COOL-GARD is a trademark of Deere & Company

IMPORTANT: Water may be used as coolant *in emergency situations only.*

Foaming, hot surface aluminum and iron corrosion, scaling, and cavitation will occur when water is used as the coolant, even when coolant conditioners are added.

Drain cooling system and refill with recommended glycol base engine coolant as soon as possible.

DX,COOL6 -19-03NOV08-1/1

Additional Information About Diesel Engine Coolants and John Deere COOL-GARD™ II Coolant Extender

Engine coolants are a combination of three chemical components: ethylene glycol (EG) or propylene glycol (PG) antifreeze, inhibiting coolant additives, and quality water.

Coolant Specifications

John Deere COOL-GARD™ II Premix either EG or PG, are fully formulated coolants that contain all three components in their correct concentrations. DO NOT add an initial charge of John Deere COOL-GARD II Coolant Extender to COOL-GARD II Premix. DO NOT add any other supplemental coolant additive or water to COOL-GARD II Premix.

John Deere COOL-GARD II Concentrate contains both ethylene glycol and inhibiting coolant additives. Mix this product with quality water, but DO NOT add an initial charge of John Deere COOL-GARD II Coolant Extender or any other supplemental coolant additive.

Replenish Coolant Additives

Some coolant additives will gradually deplete during engine operation. Periodic replenishment of inhibitors is required, even when John Deere COOL-GARD II Premix or COOL-GARD II Concentrate is used. Follow the recommendations in this manual for the use of John Deere COOL-GARD II Coolant Extender.

Why use John Deere COOL-GARD II Coolant Extender?

Operating without proper coolant additives will result in increased corrosion, cylinder liner erosion and pitting, and other damage to the engine and cooling system. A simple mixture of ethylene glycol or propylene glycol and water will not give adequate protection.

John Deere COOL-GARD II Coolant Extender is a chemically matched additive system designed to fortify the proprietary additives used in John Deere COOL-GARD II Premix and COOL-GARD II Concentrate and to provide optimum protection for up to six years or 6000 hours of operation.

COOL-GARD is a trademark of Deere & Company

Avoid Automotive-type Coolants

Never use automotive-type coolants (such as those meeting ASTM D3306). These coolants do not contain the correct additives to protect heavy-duty diesel engines. Do not treat an automotive engine coolant with supplemental coolant additives because the high concentration of additives can result in additive fallout.

Water Quality

Water quality is important to the performance of the cooling system. Distilled, deionized, or demineralized water is recommended for mixing with ethylene glycol and propylene glycol base engine coolant concentrate. All water used in the cooling system should meet the following minimum specifications for quality:

Chlorides	<40 mg/L
Sulfates	<100 mg/L
Total dissolved solids	<340 mg/L
Total hardness	<170 mg/L
pH	5.5 to 9.0

Freeze Protection

The relative concentrations of glycol and water in the engine coolant determine its freeze protection limit.

Ethylene Glycol	Freeze Protection Limit
40%	-24°C (-12°F)
50%	-37°C (-34°F)
60%	-52°C (-62°F)
Propylene Glycol	Freeze Protection Limit
40%	-21°C (-6°F)
50%	-33°C (-27°F)
60%	-49°C (-56°F)

DO NOT use a coolant-water mixture greater than 60% ethylene glycol or 60% propylene glycol.

DX,COOL17 -19-20APR11-1/1

Testing Diesel Engine Coolant

Maintaining adequate concentrations of glycol and inhibiting additives in the coolant is critical to protect the engine and cooling system against freezing, corrosion, and cylinder liner erosion and pitting.

Test the coolant solution at intervals of 12 months or less and whenever excessive coolant is lost through leaks or overheating.

Coolant Test Strips

Coolant test strips are available from your John Deere dealer. These test strips provide a simple, effective method to check the freeze point and additive levels of your engine coolant.

When Using John Deere COOL-GARD II

John Deere COOL-GARD II Premix™, COOL-GARD II PG Premix and COOL-GARD II Concentrate are maintenance free coolants for up to six years or 6000 hours of operation, provided that the cooling system is topped off using only John Deere COOL-GARD II Premix or COOL-GARD II PG premix. Test the coolant condition annually with coolant test strips designed for use with John Deere COOL-GARD II coolants. If the test strip chart indicates that additive is required, add John Deere COOL-GARD II Coolant Extender as directed.

COOL-GARD is a trademark of Deere & Company

Add only the recommended concentration of John Deere COOL-GARD II Coolant Extender. DO NOT add more than the recommended amount.

When Using Nitrite-Containing Coolants

Compare the test strip results to the supplemental coolant additive (SCA) chart to determine the amount of inhibiting additives in your coolant and whether more John Deere Liquid Coolant Conditioner should be added.

Add only the recommended concentration of John Deere Liquid Coolant Conditioner. DO NOT add more than the recommended amount.

Coolant Analysis

For a more thorough evaluation of your coolant, perform a coolant analysis. The coolant analysis can provide critical data such as freezing point, antifreeze level, pH, alkalinity, nitrite content (cavitation control additive), molybdate content (rust inhibitor additive), silicate content, corrosion metals, and visual assessment.

Contact your John Deere dealer for more information on coolant analysis.

DX,COOL9 -19-11APR11-1/1

Hydraulic and Hydrostatic Oil

Use oil viscosity based on the expected air temperature range during the period between oil changes.

Your machine was shipped from the factory with engine oil in the hydraulic system. Engine oil has been tested to be compatible with high quality anti wear hydraulic oils (AWHO). There is no risk to the hydraulic system of using a high quality AWHO meeting the system oil specifications to top off the system, or for future oil changes.

The following oil is preferred:

- John Deere PLUS-50™ II

The following oil is also recommended:

- John Deere Torq-Gard™

Other oils may be used if they meet one or more of the following:

- API Service Classification CH-4 or better

*PLUS-50 is a trademark of Deere & Company
Torq-Gard is a trademark of Deere & Company*

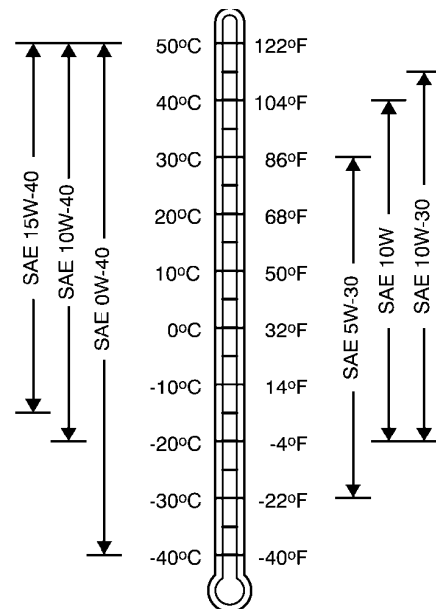

T148385—UN—19NOV01

OUT4001,0000497 -19-28MAR11-1/1

Hydrostatic Planetary Gear Case Oil

Use oil viscosity based on the expected air temperature range during the period between oil changes.

The following oil is preferred:

- John Deere GL-5 GEAR LUBRICANT

Other oils may be used if they meet API Service Classification GL-5.

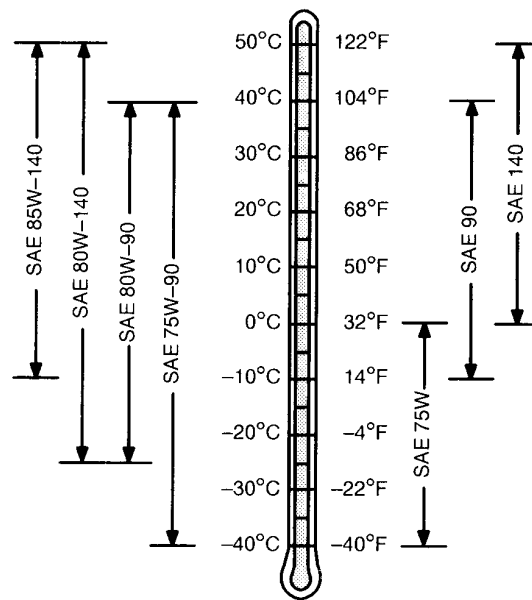

Gear Oil

OUT4001,0000496 -19-06DEC12-1/1

TS1653 —UN—14MAR96

Grease

Use grease based on NLGI consistency numbers and the expected air temperature range during the service interval.

John Deere SD Polyurea Grease is preferred.

The following greases are also recommended:

- John Deere HD Lithium Complex Grease
- John Deere HD Water Resistant Grease
- John Deere GREASE-GARD™

Other greases may be used if they meet the following:

- NLGI Performance Classification GC-LB

IMPORTANT: Some types of grease thickeners are not compatible with others. Consult your grease supplier before mixing different types of grease.

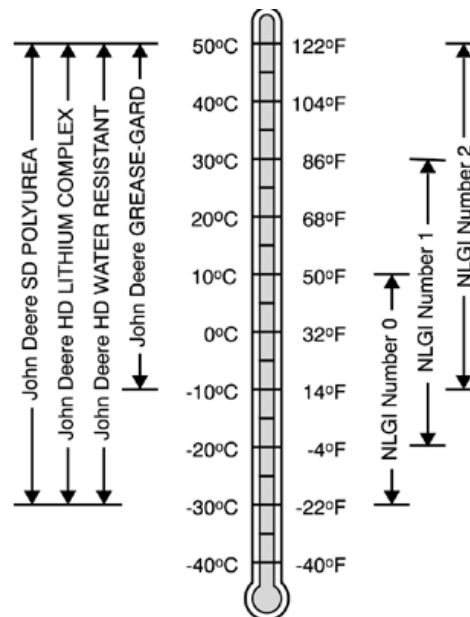

Greases for Air Temperature Ranges

DX,GRE1 -19-14APR11-1/1

TS1673 —UN—31OCT03

GREASE-GARD is a trademark of Deere & Company

Maintenance—Periodic Maintenance

Service Machine at Specified Intervals

Lubricate and make service checks and adjustments at intervals shown on the periodic maintenance chart (1) and on the following pages. Periodic maintenance chart is located on the inside of the engine cover.

Perform service on items at multiples of the original requirement. For example, at 500 hours, also service those items, if applicable, listed under 250 hours, 50 hours, and 10 hours or daily.

1— Periodic Maintenance Chart

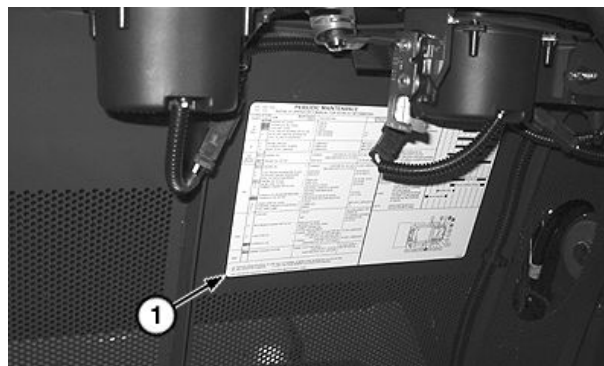

TX1065084A —UN—25SEP09

OUT4001,00004B1 -19-25SEP09-1/1

Fuel Tank

CAUTION: Prevent possible injury from fire. Handle fuel carefully. If the engine is hot or running, **DO NOT** fill the fuel tank. **DO NOT** smoke while filling the fuel tank or working on fuel system.

To avoid condensation, fill the fuel tank at the end of each day's operation. Shut off engine before filling.

Specification

Fuel Tank—Capacity..... 70.0 L
19.0 gal

OUT4001,00004AD -19-05NOV09-1/1

Raising and Blocking Machine

1. Park machine.
2. Place safe lifting device under the front center of machine base and raise machine.
3. Place blocks/stands under the front corners (1) of machine base.
4. Lower machine onto blocks/stands.
5. Place safe lifting device under the rear center of machine base and raise machine.
6. Place blocks/stands under the rear corners (2) of machine base.
7. Lower machine onto blocks/stands.

1—Front Corner

2—Rear Corner

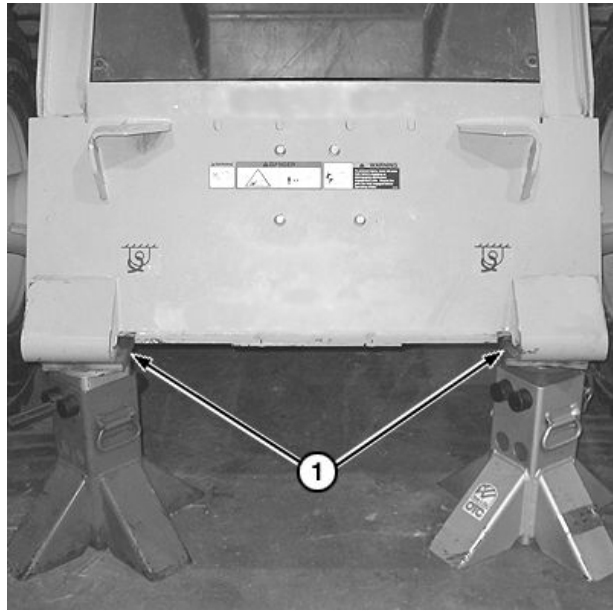

TX1066547A —UN—20OCT09

Boom Raised for Picture Clarity

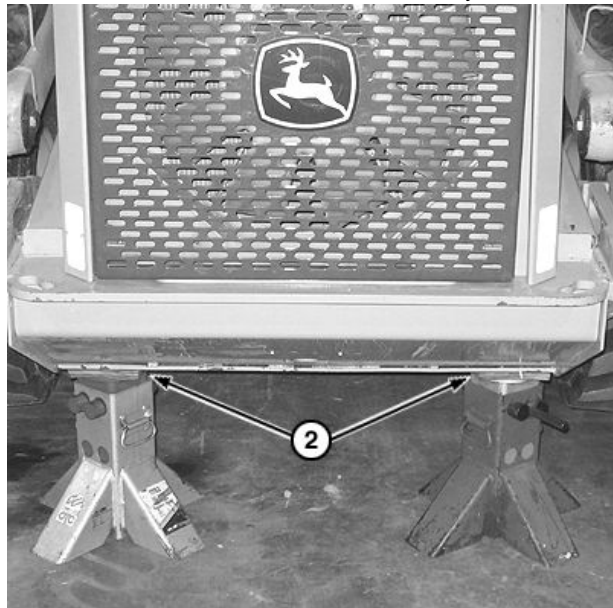

TX1066548A —UN—20OCT09

OUT4001.00004FD -19-25OCT10-1/1

Raising Operator's Station

1. Park machine on level surface, shut off engine.
2. Remove nuts (1) and washers from mounting studs on both sides of outer front edge of operator's station.

CAUTION: Prevent crushing injury from unexpected cab movement. Replace gas spring cylinder if:

- Cylinder is cracked or damaged.
- The operator's station is hard to lift.

NOTE: NEVER attempt to repair a damaged gas spring cylinder. See your authorized dealer.

3. Using hand holds, raise operator's station. If manual equipped machine, make sure control levers fall forward. Continue raising operator's station all the way up so that gas spring cylinder locks are in place.
4. Pull forward on red cylinder lock (2) to ensure operator's station is in locked position.

NOTE: If machine is equipped with a pressurized cab, make sure that seal on back of footwell is in place prior to lowering cab.

5. To lower operator's station, push red cylinder lock rearward to unlocked position (3).
6. Pull operator's station down until seated on mounting studs.
7. Install and tighten washers and nuts on mounting studs.
8. Verify that mounting studs are tight.

- | | |
|--|----------------------|
| 1— Nut (2 used) | 3— Unlocked Position |
| 2— Red Cylinder Lock (locked position) | |

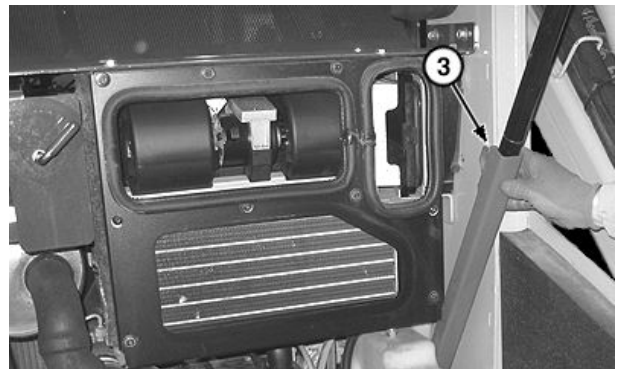

TX1066452A —UN—17OCT09

TX1066453A —UN—17OCT09

TX1066454A —UN—17OCT09

OUT4001,0000492 -19-08OCT10-1/1

Opening and Closing Engine Cover

Opening engine cover (3):

1. Park machine and shut engine OFF.
2. Remove key.

NOTE: Ignition key is also used for lock on engine cover.

3. Unlock the engine cover on the lock assembly (1).
4. Push in lock assembly and lift the engine cover using the handle (2).
5. Move prop guide (4) into the retainer (5) to hold the engine cover in open position.

Closing engine cover:

1. Hold on to handle of engine cover and move the prop guide out of the retainer.
2. Close engine cover and ensure it is securely latched.
3. Lock with ignition key.

1—Lock Assembly
2—Handle
3—Engine Cover

4—Prop Guide
5—Retainer

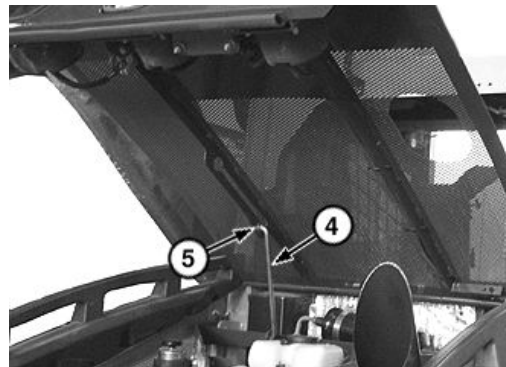

OUT4001,0000494 -19-14SEP09-1/1

TX1064325A—UN—10SEP09

TX1064326A—UN—10SEP09

Engine Side Panels—Remove and Install

Removing engine side panels (1):

NOTE: Boom does not have to be raised to remove engine side panels.

1. Park machine.
2. Open engine cover and insert prop rod in retainer to hold in open position. (See Opening and Closing Engine Cover in this section.)
3. Tilt engine side panels rearward and lift off.

1—Engine Side Panel (2 used,
1 per side)



Boom Raised and Locked for Picture Clarity

Continued on next page

OUT4001,0000493 -19-31MAR10-1/2

TX1064360A—UN—11SEP09

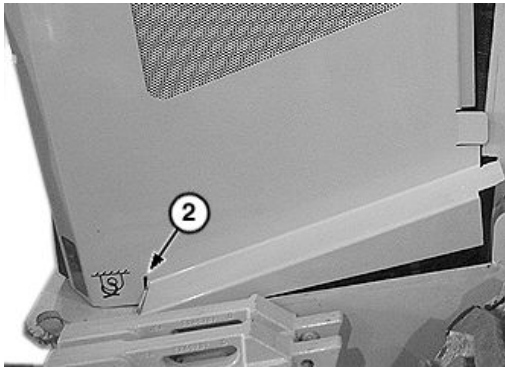

TX1064363A—UN—11SEP09

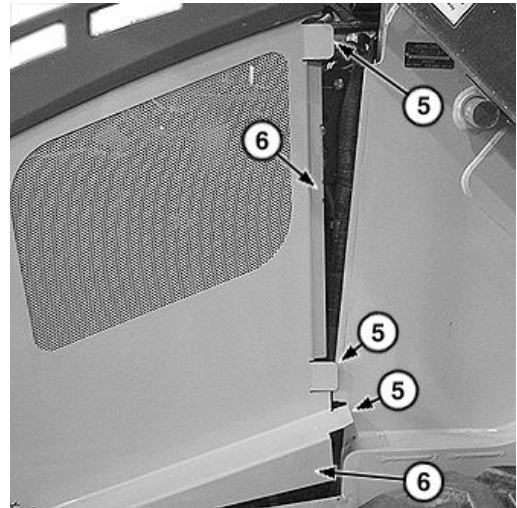

TX1064367A—UN—10NOV09

Installing engine side panels:

1. Line up bottom rear corner of engine side panel so the slot (2) on engine side panel fits into the tab on machine.
2. Tilt engine side panel forward ensuring that the outer tabs (5) on front side of engine side panel stay to the outer edge of machine frame and the long inside tabs (6) stay to the inner edge of machine frame.

IMPORTANT: Avoid machine damage. Make sure engine side panel tabs are engaged in slots.

3. Line up metal tab (3) on inside of engine side panel with the slot on rubber guide (4) mounted to the back of machine.
4. Close engine cover.

2— Slot
3— Tab
4— Guide

5— Outer Tab (3 used)
6— Inside Tab (2 used)

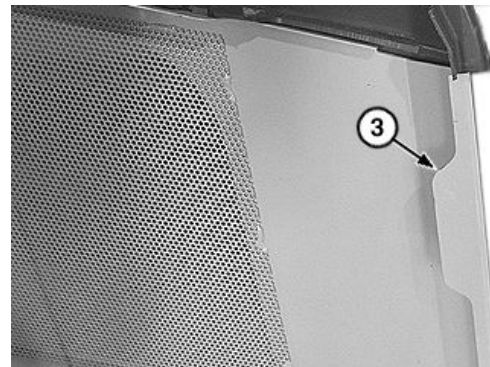

TX1064364A—UN—11SEP09

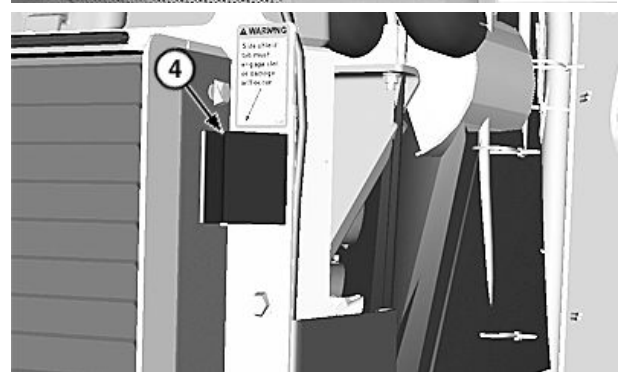

TX1075271A—UN—31MAR10

OUT4001,0000493 -19-31MAR10-2/2

Footwell Removal

1. Park machine on level surface.
2. Remove any attachment.
3. Raise boom and lock in raised position.
4. Stop engine and engage park brake.
5. Raise and lock operator's station in up position.
6. Remove cap screws (1) from footwell (2).

NOTE: For manual machines, ensure control lever boot is disengaged from footwell before removing. During installation, ensure the base of control lever boot snaps in groove of footwell.

7. Lift out footwell.

1—Cap Screw (6 used, 3 per side) 2—Footwell

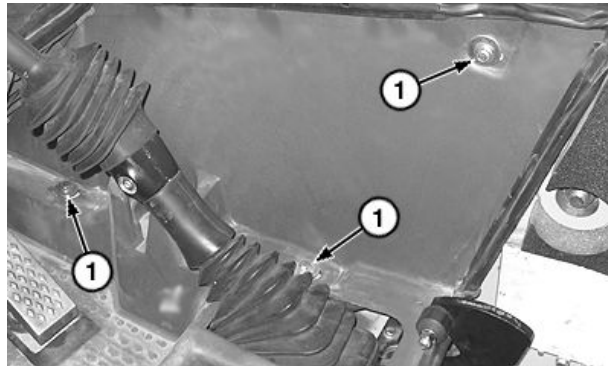

Right Side of Manual Machine Shown



TX1066492A—UN—09APR10

TX1066483A—UN—09APR10

OUT4001.00004FE -19-10NOV09-1/1

Fluid Analysis Program Test Kits and 3-Way Coolant Test Kit

Fluid Analysis Program Test Kits and the 3-Way Coolant Test Kit are John Deere fluid sampling products to help you monitor machine maintenance and system condition. The objective of a fluid sampling program is to ensure machine availability when you need it and to reduce repair costs by identifying potential problems before they become critical.

Engine, hydraulic, power train, and coolant samples should be taken from each system on a periodic basis, usually prior to a filter and/or fluid change interval. Certain systems require more frequent sampling. Consult your authorized John Deere dealer on a maintenance program for your specific application. Your authorized John Deere dealer has the sampling products and expertise to assist you in lowering your overall operating costs through fluid sampling.



Fluid Analysis Kits

TX1003513A—UN—20FEB06

AM40430.00002FE -19-19OCT11-1/1

Service Intervals

Model: 319D and 323D Skid Steer		PIN/Serial Number:	
Hour Meter Reading:			
SERVICE INTERVALS			
Service machine at intervals shown on this chart. Also, perform service on items at multiples of the original requirement. For example, at 500 hours also service those items (if applicable) listed under 250 hours, 50 hours, and 10 hours or daily.			
FLUID SAMPLING			
Fluid samples should be taken from each system at its recommended change interval prior to actually draining the fluid. Regular oil sampling will extend the operational life of your machine.			
As Required			
<input type="checkbox"/> Inspect and clean cooling package		<input type="checkbox"/> Check and clean cab recirculation air filter (if equipped)	
<input type="checkbox"/> Check and clean cab fresh air filter (if equipped)		<input type="checkbox"/> Inspect and clean fuel tank vent tube	
<input type="checkbox"/> Add coolant extender as indicated by COOL-GARD™ II test strips			
Every 10 Hours or Daily			
<input type="checkbox"/> Check engine oil level		<input type="checkbox"/> Check coolant level	
<input type="checkbox"/> Check hydraulic reservoir oil level		<input type="checkbox"/> Check and drain water separator fuel filter	
Initial Service - 50 Hours¹			
<input type="checkbox"/> Change hydrostatic planetary gear case oil (S.N. 192142—)			
¹ Perform initial service once after the first 50 hours of operation and then at 1000 hour intervals thereafter.			
Every 50 Hours			
<input type="checkbox"/> Lubricate boom linkage, cylinder pivot points, and Quik-Tatch™ linkage		<input type="checkbox"/> Check track tension	
Initial Service - 250 Hours²			
<input type="checkbox"/> Change engine oil and replace filter		<input type="checkbox"/> Change hydrostatic planetary gear case oil (S.N. —192141)	
² Perform initial service once after the first 250 hours of operation and then at 500 hour intervals thereafter.			
Every 250 Hours			
<input type="checkbox"/> Take engine oil sample			
Every 500 Hours			
<input type="checkbox"/> Change engine oil and replace filter		<input type="checkbox"/> Lubricate steering linkage (if equipped)	
<input type="checkbox"/> Replace water separator fuel filter		<input type="checkbox"/> Drain fuel tank sump	
<input type="checkbox"/> Replace in-line fuel filter		<input type="checkbox"/> Take hydraulic oil sample	
<input type="checkbox"/> Replace primary engine air filter		<input type="checkbox"/> Take gear case oil sample	
<input type="checkbox"/> Replace hydraulic oil reservoir breather		<input type="checkbox"/> Take diesel fuel sample	
<input type="checkbox"/> Replace hydraulic oil filter		<input type="checkbox"/> Take engine coolant sample	
<input type="checkbox"/> Change hydrostatic planetary gear case oil (S.N. —192141)			
Every 1000 Hours			
<input type="checkbox"/> Check coolant		<input type="checkbox"/> Change hydraulic reservoir oil	
<input type="checkbox"/> Replace secondary engine air filter		<input type="checkbox"/> Change hydrostatic planetary gear case oil (S.N. 192142—)	
Every 6000 Hours			
<input type="checkbox"/> Drain, flush, and refill cooling system			

COOL-GARD is a trademark of Deere & Company
 Quik-Tatch is a trademark of Deere & Company

ER79617,0000C48 -19-22OCT10-1/1

Required Parts

Description	Part Number	Initial Service - 50 Hours ¹	Initial Service - 250 Hours ²	Every 250 Hours	Every 500 Hours	Every 1000 Hours	Every 6000 Hours
Engine Oil Filter	RE519626		1		1	1	1
In-Line Fuel Filter	T257865				1	1	1
Water Separator Fuel Filter	RE533026				1	1	1
Hydraulic Oil Reservoir Breather	AT101565				1	1	1
Hydraulic Oil Filter	AT314164				1	1	1
Primary Engine Air Filter	AT396133				1	1	1
Secondary Engine Air Filter	RE282287					1	1
PLUS-50™ II Engine Oil	TY26674 ³		9.0 L (2.4 gal.)		9.0 L (2.4 gal.)	9.0 L (2.4 gal.)	9.0 L (2.4 gal.)
PLUS-50™ II Hydraulic & Hydrostatic Oil	TY26674 ³					19.0 L (5.0 gal.)	19.0 L (5.0 gal.)
Hydrostatic Planetary Gear Case Oil (per side) (S.N. —192141)	TY6382 ³		0.55 L (18.6 oz.)		0.55 L (18.6 oz.)	0.55 L (18.6 oz.)	0.55 L (18.6 oz.)
Hydrostatic Planetary Gear Case Oil (per side) (S.N. 192142—)	TY6382 ³	0.79 L (27.0 oz.)				0.79 L (27.0 oz.)	0.79 L (27.0 oz.)
COOL-GARD™ II Pre-Mix	TY26575						9.3 L (2.5 gal.)
Coolant Extender	TY26603				As Required		
Fluid Analysis Kits⁴							
Diesel Engine Oil	AT346594			1	1	1	1
Hydrostatic and Hydraulic Oil	AT346594				1	1	1
Planetary Gear Case Oil	AT346594				2	2	2
Diesel Fuel	AT180344				1	1	1
Engine Coolant	TY26873				1	1	1
COOL-GARD™ II Test Strips	TY26605					1	1

¹Perform initial service once after the first 50 hours of operation and then at 1000 hour intervals thereafter.

²Perform initial service once after the first 250 hours of operation and then at 500 hour intervals thereafter.

³For recommended oil types and oil viscosities based on operating temperatures, see Maintenance-Machine. (Section 3-1.)

⁴Based on fluid analysis results, intervals may need to be adjusted for operating conditions. Consult your local John Deere dealer.

PLUS-50 is a trademark of Deere & Company
COOL-GARD is a trademark of Deere & Company

ER79617,0000C49 -19-16MAY13-1/1

Maintenance—As Required

Inspect and Clean Cooling Package

Check radiator (3), hydraulic oil cooler (4), charge air cooler (5), and air conditioner condenser (1), if equipped, for dirt, damage, leaks, and loose or broken mounting hardware.

1. Park machine.
2. Raise boom and lock in raised position.

CAUTION: Prevent personal injury. Allow engine to cool enough so that components can be touched with bare hands.

3. Open engine cover and lock in open position.
4. Remove engine side panels.
5. On left side of machine, remove pin (2) and swing open air conditioner condenser.
6. Clean air conditioner condenser and radiator fins using compressed air.
7. Close air conditioner condenser and attach pin.
8. On right side of machine, clean hydraulic oil cooler and charge air cooler fins using compressed air.
9. Clean any dirt build-up in engine area.
10. If any areas require washing after cleaning with air, allow radiator and cooler parts to dry thoroughly before operating machine.
11. Install engine side panels and close engine cover.
12. Lower boom.

1— Air Conditioner Condenser 4— Hydraulic Oil Cooler
2— Pin 5— Charge Air Cooler
3— Radiator

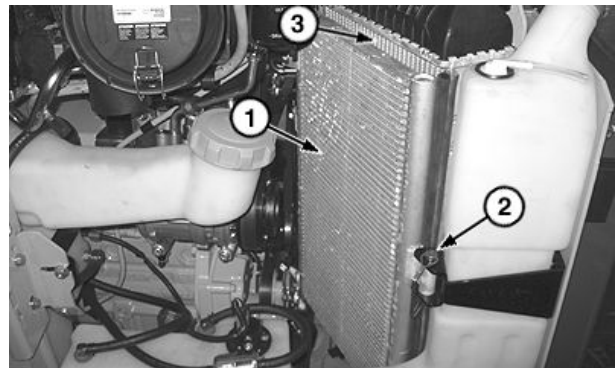

Left Side of Machine Shown

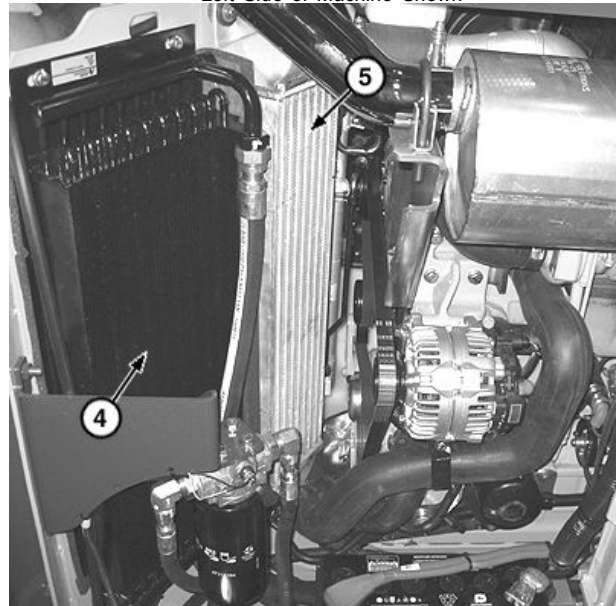

Right Side of Machine Shown

TX1065347A —UN—05OCT09

TX1065353A —UN—02OCT09

OUT4001,00004B3 -19-04DEC09-1/1

Check and Clean Cab Fresh Air and Recirculation Air Filters—If Equipped

NOTE: Check air filters periodically, especially if running in dirty applications.

1. Park machine.
2. Behind operator's seat, remove knobs (1) that hold on guard (2).
3. Remove guard.
4. Remove cab fresh air filter (3) and recirculation air filter (4).
5. The filters can be blown off with a low pressure air gun and reused. Replace, if damaged.
6. Install filters.
7. Install guard and knobs.

1—Knob (2 used)
2—Guard

3—Cab Fresh Air Filter
4—Recirculation Air Filter

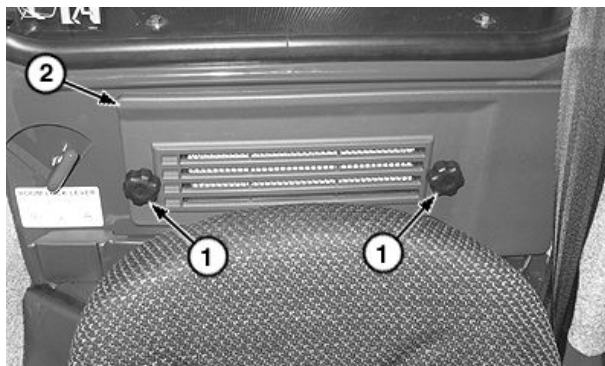

Air Filter Guard

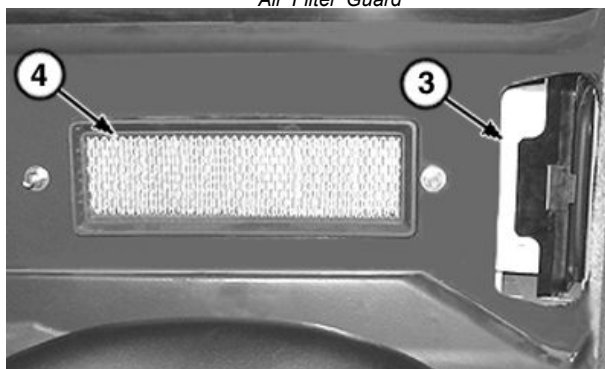

Cab Fresh Air and Recirculation Air Filters

TX1065424A —UN—01OCT09

TX1065425A —UN—06JUN13

OUT4001,00004B5 -19-09NOV12-1/1

Inspect and Clean Fuel Tank Vent Tube

Inspect fuel tank vent tube (1) for debris. Remove and clean as necessary.

1—Fuel Tank Vent Tube

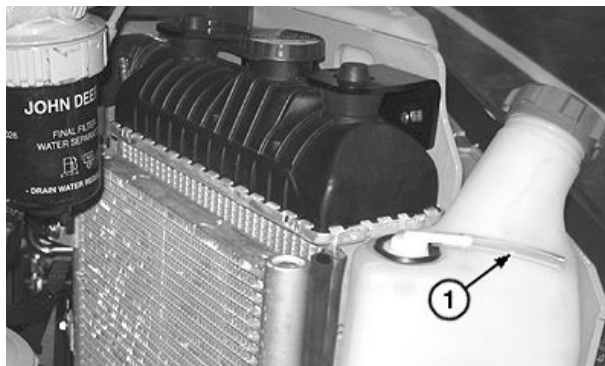

TX1065433A —UN—01OCT09

OUT4001,00004B7 -19-13OCT09-1/1

Check Coolant

CAUTION: Explosive release of fluids from pressurized cooling system can cause serious burns.

Prevent possible injury from hot spraying water. Shut off engine. Remove filler cap only when cool enough to touch with bare hands. Slowly loosen cap to first stop to relieve pressure before removing completely.

IMPORTANT: John Deere COOL-GARD™ II Coolant Extender does not protect against freezing. Coolant extender prevents rust, scale, and liner cavitation.

NOTE: Check coolant every 1000 hours or 1 year, or when replacing 1/3 or more of coolant. Add coolant extender as indicated by John Deere COOL-GARD™ II test strips.

1. Remove radiator cap (1) and test coolant solution. Use the following kit to check coolant:

• **COOL-GARD™ II Test Strips**

Coolant test strips provide an effective method to check freeze point and additive levels of engine coolant. See your authorized dealer for COOL-GARD™ II test strips and follow instructions on kit.

2. Add John Deere COOL-GARD™ II Coolant Extender as necessary. Follow instructions on container for amount.

Specification

Cooling System—Capacity..... 9.3 L
2.5 gal

COOL-GARD is a trademark of Deere & Company



1— Radiator Cap

3. Install radiator cap.

TS281—UN—15APR13

TX1065436A—UN—02OCT09

OUT4001,00004D4 -19-21FEB13-1/1

Maintenance—Every 10 Hours or Daily

Check Engine Oil Level

IMPORTANT: Prevent engine damage. DO NOT run engine when oil level is below the ADD mark.

The most accurate oil level reading is obtained when the engine is cold before starting the engine for the day's operation.

1. Open engine cover.
2. Make sure dipstick (1) is fully seated.
3. Remove dipstick to check oil level.

BEFORE THE ENGINE IS STARTED: The engine is full when oil level is in the cross hatch area. It is acceptable to run the engine when the oil level is above the ADD mark.

AFTER THE ENGINE HAS BEEN RUN: Allow the oil to drain into the oil pan for 10 minutes before checking the oil level. Ten minutes after shutdown the engine oil level must be above the ADD mark.

4. If necessary, remove fill tube cap (2) to add oil. For recommended oil, see Maintenance—Machine. (Section 3-1.)

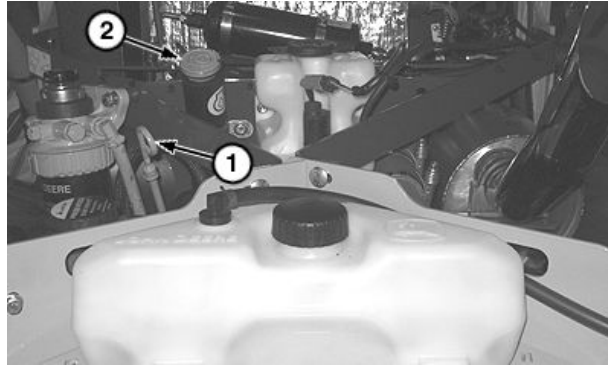

1—Dipstick

2—Fill Tube Cap

5. Close engine cover.

OUT4001,00004B8 -19-29SEP09-1/1

TX1065494A—UN—02OCT09

Check Hydraulic Reservoir Oil Level

IMPORTANT: To ensure an accurate reading, park machine on smooth level ground and check level only when hydraulic oil is cold and boom is down with boom and bucket cylinders fully retracted.

When adding oil to the hydraulic reservoir, be careful not to get dirt into reservoir or oil.

Do not overfill hydraulic oil reservoir. An overfilled hydraulic oil reservoir will not allow for oil expansion, which may result in oil leakage past hydraulic reservoir breather or fill cap.

1. Park machine.
2. Check oil level at sight glass (1) on left side of machine. Oil level should be between the two arrows.
3. If necessary, add oil. Open engine cover and remove left engine side panel.
 - Remove hydraulic reservoir fill cap (2). For recommended oil, see Hydraulic and Hydrostatic Oil. (Section 3-1.)
 - Install fill cap.
4. Install left engine side panel.
5. Close engine cover.

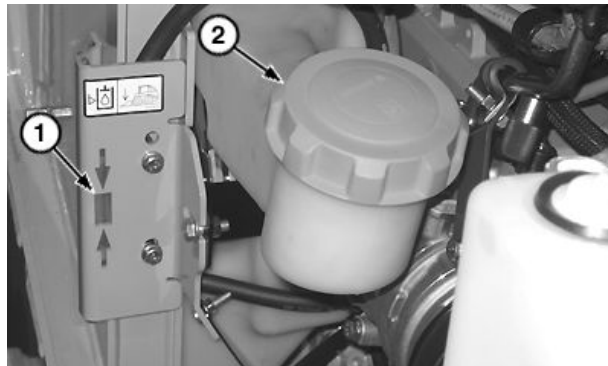
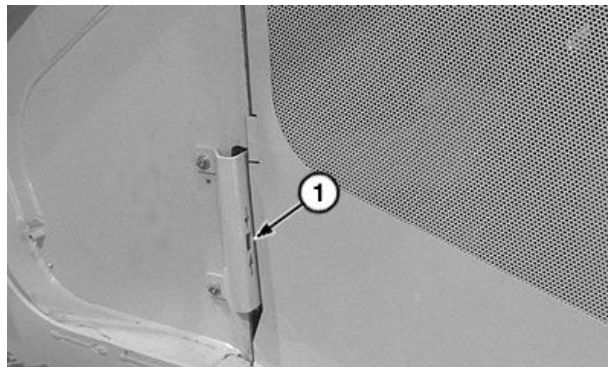

Boom Raised for Picture Clarity

1—Sight Glass

2—Hydraulic Reservoir Fill Cap

OUT4001,00004B9 -19-11NOV09-1/1

TX1065496A—UN—02OCT09

TX1065497A—UN—08OCT09

Check Coolant Level

CAUTION: Prevent possible injury from hot spraying water. Shut off engine. Remove filler cap only when cool enough to touch with bare hands. Slowly loosen cap to first stop to relieve pressure before removing completely.

Check coolant level by viewing coolant in overflow tank (2) when engine is cold.

1. Park machine.
2. Allow engine to cool.
3. Open engine cover.
4. Check overflow tank for coolant level. Coolant should be above the MIN COLD line (3), but below the MAX COLD line (4).
5. If coolant is below the MIN COLD line, add coolant to the overflow tank. For recommended coolant, see Maintenance—Machine. (Section 3-1.)
6. Close engine cover and run engine.

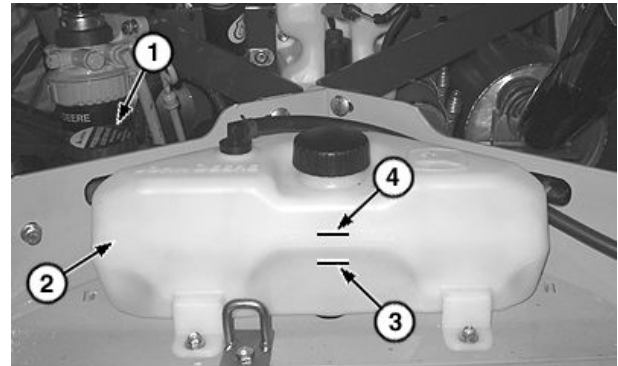

1— Radiator Cap
2— Overflow Tank

3— MIN COLD Line
4— MAX COLD Line

7. Allow engine to cool and check coolant level again on overflow tank.
8. If level is still low on overflow tank, repeat procedure as necessary.

OUT4001,00004BA -19-21FEB13-1/1

TX106510A —UN—02OCT09

Check and Drain Water Separator Fuel Filter

1. Park machine.
2. Open engine cover and remove left engine side panel.
3. Place a suitable container under drain valve (2) of water separator fuel filter (1).
4. Loosen drain valve to drain water and sediment into container. Dispose of waste properly.
5. Tighten drain valve.
6. Install left engine side panel.
7. Close engine cover.

1— Water Separator Fuel Filter 2— Drain Valve

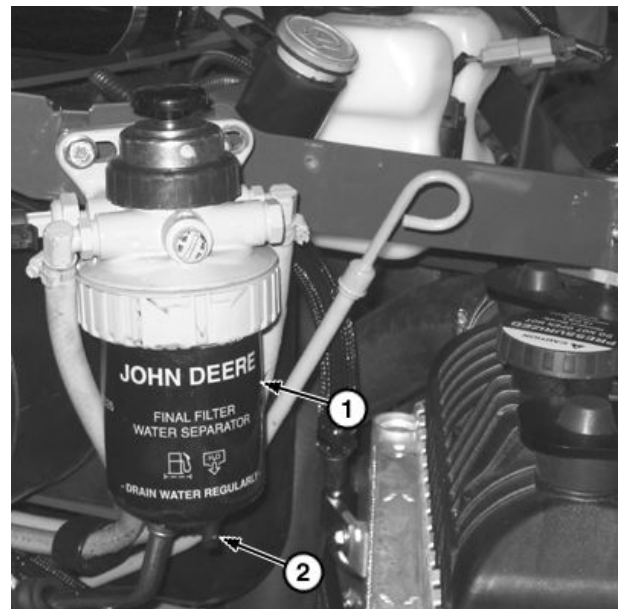

OUT4001,00004BB -19-09OCT09-1/1

TX106525A —UN—10OCT09

Maintenance—Initial Service - 50 Hours

Change Hydrostatic Planetary Gear Case Oil (S.N. 192142—)

NOTE: Perform this service at the first 50 hours of operation and then at 1000 hour intervals thereafter.

1. Park the machine on a level surface until drain plug (2) is at the bottom of gear case.
2. Stop engine.

⚠ CAUTION: High-pressure release of fluids from a pressurized system can cause serious burns. Wait for hydrostatic planetary gear case oil to cool. Keep body and face away from check plug. Gradually loosen fill plug to release pressure.

3. Allow machine to cool. Slowly loosen the fill plug (1) to release pressure.
4. Remove drain plug. Allow oil to drain into a container. Dispose of waste properly.
5. Install drain plug.
6. Remove fill plug completely.
7. Remove check plug (3).
8. Add oil to fill plug hole until oil flows out of the check plug hole. For recommended oil, see Maintenance—Machine. (Section 3-1.)

Specification

Hydrostatic Planetary
Gear Case Oil (S.N.
192142—)—Capacity
(per side)..... 0.79 L
27.0 oz.

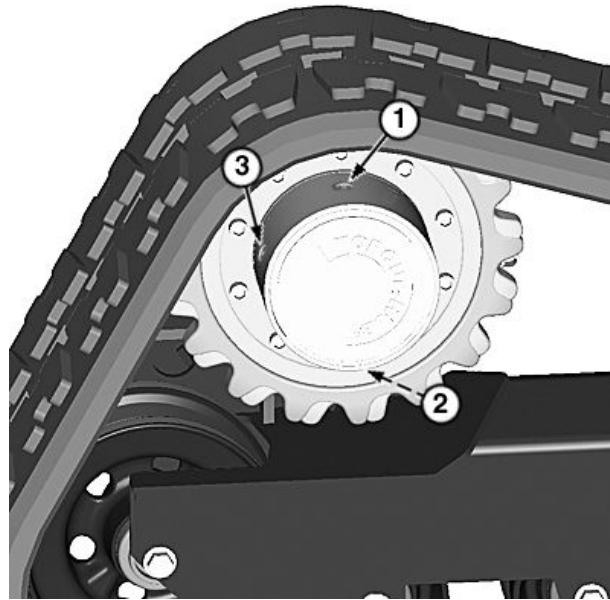

Hydrostatic Planetary Gear Case (S.N. 192142—)

- 1— Fill Plug
- 2— Drain Plug
- 3— Check Plug

9. Install check and fill plugs.

TX1081205A—UN—24AUG10

ER79617.0000C3F -19-22OCT10-1/1

Maintenance—Every 50 Hours

Lubricate Boom Linkage, Cylinder Pivot Points, and Quik-Tatch™ Linkage

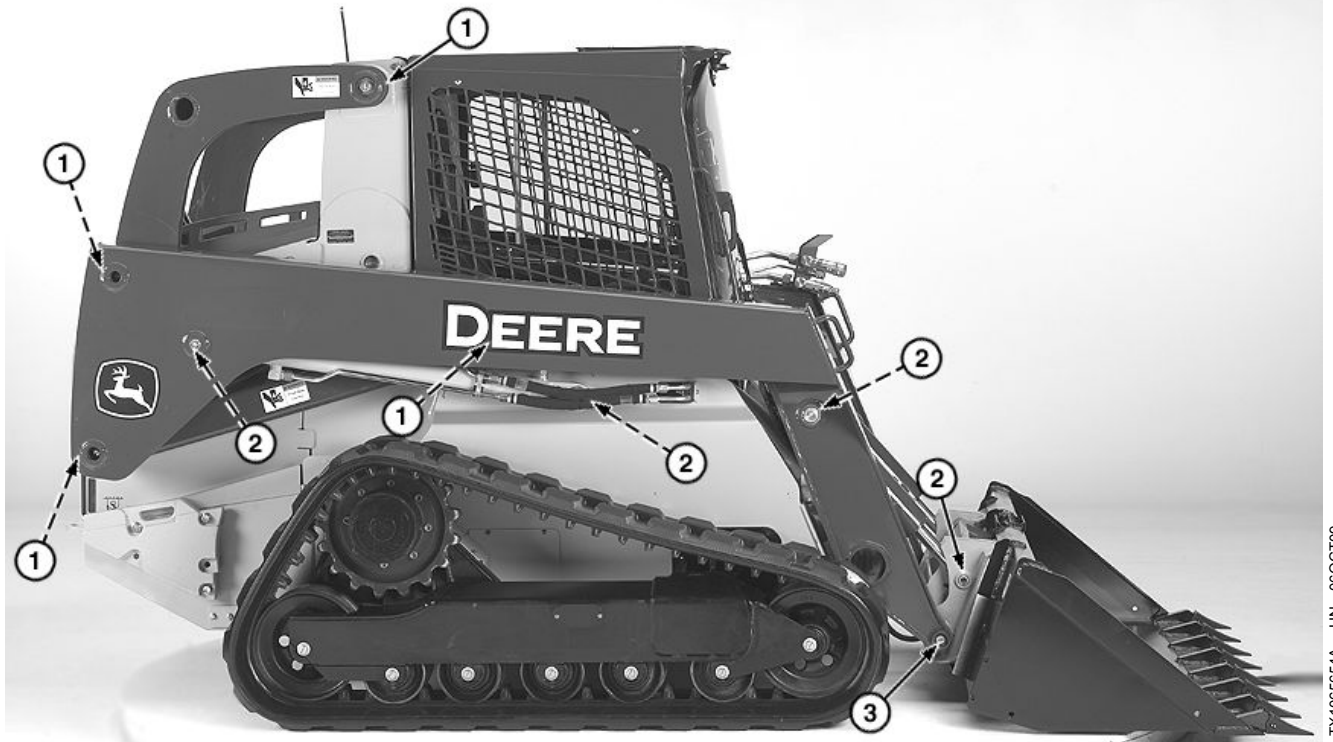

TX 1065654A —UN—06OCT09

Right Side Shown

1— Boom Linkage Point (8 used) 2— Cylinder Pivot Point (8 used) 3— Quik-Tatch™ Linkage Point (2 used)

NOTE: In severe operating conditions, Quik-Tatch™ linkage points (3) may need more frequent lubrication.

boom every 50 hours with one or two shots of grease. For recommended grease, see Grease. (Section 3-1.)

Lubricate boom linkage points (1), cylinder pivot points (2), and Quik-Tatch™ linkage points (3) on each side of Quik-Tatch is a trademark of Deere & Company

OUT4001,00004D5 -19-14OCT09-1/1

Check Track Tension

IMPORTANT: Avoid track damage. Track sag measurement can only be performed safely and accurately by using a bucket to raise machine to proper height. DO NOT use a broken or worn out bucket when checking or adjusting track sag.

1. Put bucket attachment on machine. Visually check pin engagement with Quik-Tatch™ to ensure locking.
2. Park machine on a hard, flat level surface.
3. Lower boom completely until it rests on stops.
4. Dump bucket to raise front end of tracks off the ground by 20 cm (8 in.).
5. Press park brake switch (1) to position P to engage park brake.
6. Turn the key switch to the OFF position.

CAUTION: Prevent injury due to unexpected machine movement during servicing. Be alert to possible machine movement caused by hydraulic leakage. If the hydraulics drift, then the machine should be blocked into the air to check track sag.

If the hydraulics drift, see your authorized dealer to remedy the problem.

7. From the seat, verify the machine is stable and the front end is still raised.

CAUTION: Avoid possible injury from falls or slips. Use care when entering and exiting machine with front end raised. Maintain three point contact. DO NOT use bucket as foothold when machine is in raised position.

Quik-Tatch is a trademark of Deere & Company



TX1064905A—UN—23SEP09

1— Park Brake Switch

8. Exit machine using handholds and top of track for assistance.

NOTE: If gravel or mud is packed between sprocket and track, it must be removed before adjusting track.

9. Measure track sag from bottom of third roller from rear of machine to top of track. The bottom of the rollers should not be touching the track.

Specification

Track —Sag (S.N. —192141).....	13-25 mm 0.50-1.00 in.
Track —Sag (S.N. 192142—).....	25-38 mm 1.00-1.50 in.

10. If track sag is not within specification, remove track adjuster cover plate on track frame.

Continued on next page

ER79617,0000C8E -19-01NOV10-1/2

⚠ CAUTION: Prevent personal injury. High pressure grease is in track adjuster cylinder. Do not loosen track adjuster valve (2) quickly or too much. Never loosen grease fitting (1) to release grease.

IMPORTANT: Prevent possible damage to track components. Do not use the grease fitting on track adjuster cylinder for lubrication. Use grease fitting only for track sag adjustment.

11. To decrease track sag, add grease to track adjuster cylinder through grease fitting (1).

To increase track sag, loosen track adjuster valve (2) one to two turns to release grease from track adjuster cylinder.

Tighten track adjuster valve when track sag is correct.

Specification

Track —Sag (S.N. —192141).....	13-25 mm 0.50-1.00 in.
Track —Sag (S.N. 192142—).....	25-38 mm 1.00-1.50 in.

12. Install track adjuster cover plate on track frame.

13. Repeat procedure for other track.

⚠ CAUTION: Avoid possible injury from falls or slips. Use care when entering and exiting

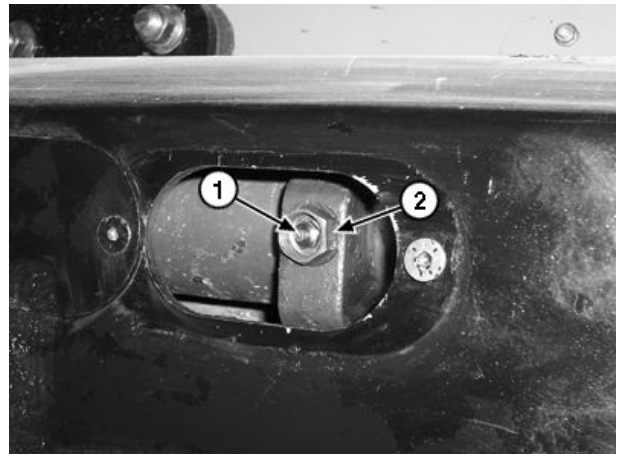

Track Adjuster

1— Grease Fitting

2— Adjuster Valve

machine with front end raised. Maintain three point contact. DO NOT use bucket as foothold when machine is in raised position.

14. Re-enter machine using top of track and handholds on machine for assistance.

15. Start machine and rollback bucket to lower front end.

TZ11663A —JN—25FEB10

ER79617,0000C8E -19-01NOV10-2/2

Maintenance—Initial Service - 250 Hours

Change Engine Oil and Replace Filter

NOTE: Replace filter and change oil initially at 250 hours, then every 500 hours thereafter when using John Deere filter and PLUS-50™ II oil.

1. Park machine.
2. Run engine a few minutes to warm oil.
3. Engage park brake and stop engine.
4. On right side of machine, remove two outer cap screws (2) from access cover (1) and pull out cover with attached engine oil drain hose.
5. Place suitable container under hose plug (3). Remove hose plug using two wrenches to avoid twisting hose. Allow oil to drain into container. Dispose of waste oil properly.

NOTE: Make sure O-ring is still intact when installing hose plug.

6. After oil is drained, install hose plug.
7. Open engine cover and remove right engine side panel.
8. Clean dirt or debris from around engine oil filter (4).
9. Place suitable container under drip tray below the engine oil filter.
10. To remove oil filter, turn filter counterclockwise using a filter wrench.
11. Allow excess oil to drain into container. Dispose of old filter and waste oil properly.
12. Apply a film of clean engine oil on seal of new filter.
13. Install filter. Turn filter until seal contacts mounting surface. Then turn filter by hand 2/3 to 1 turn more.

- | | |
|-----------------------|----------------------|
| 1— Access Cover | 3— Hose Plug |
| 2— Cap Screw (2 used) | 4— Engine Oil Filter |

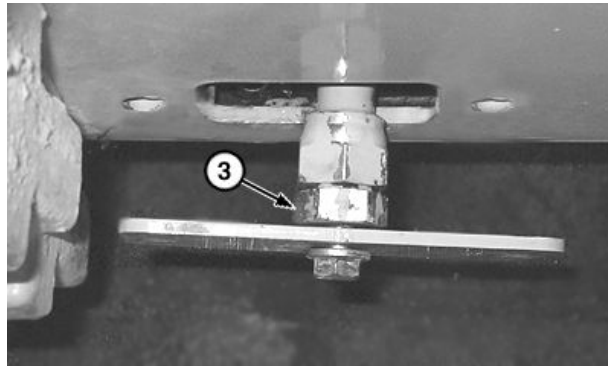
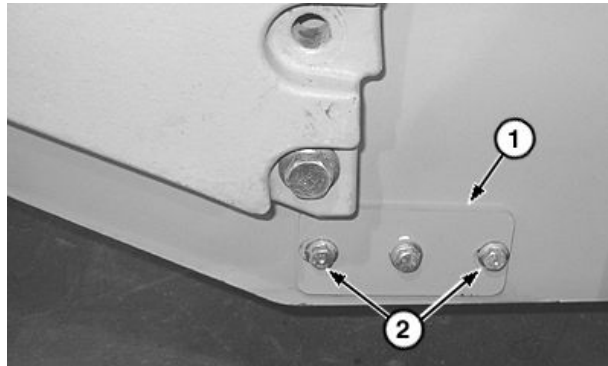

PLUS-50 is a trademark of Deere & Company

Continued on next page

OUT4001,00004BE -19-10NOV09-1/2

TX1065666A—UN—06OCT09

TX1065667A—UN—10NOV09

TX1065671A—UN—06OCT09

14. Remove engine oil fill cap (5).

IMPORTANT: Do not overfill. If overfilled, oil can cause engine damage.

15. Add oil. For recommended oil, see Diesel Engine Oil. (Section 3-1.)

Specification

Engine—Oil Capacity	
With Filter.....	9.0 L 2.4 gal

16. Check engine oil level on dipstick (6).

17. Install and tighten fill cap.

18. Start engine, and run at slow speed for 2 minutes. Check for leaks around filter and drain plug.

19. Check engine oil level on dipstick again.

20. Push in access cover and install cap screws.

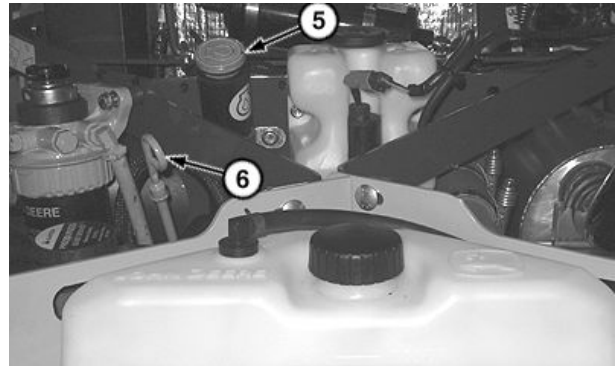

5— Engine Oil Fill Cap

6— Dipstick

21. Install right engine side panel and close engine cover.

OUT4001,00004BE -19-10NOV09-2/2

TX1065673A —UN—06OCT09

Change Hydrostatic Planetary Gear Case Oil (S.N. —192141)

NOTE: Perform this service at the first 250 hours of operation and then at 500 hour intervals thereafter.

1. Park the machine on a level surface until drain plug (2) is at the bottom of gear case.
2. Stop engine.

CAUTION: High-pressure release of fluids from a pressurized system can cause serious burns. Wait for hydrostatic planetary gear case oil to cool. Keep body and face away from check plug. Gradually loosen fill plug to release pressure.

3. Allow machine to cool. Slowly loosen the fill plug (1) to release pressure.
4. Remove drain plug. Allow oil to drain into a container. Dispose of waste properly.
5. Install drain plug.
6. Remove fill plug completely.
7. Remove check plug (3).
8. Add oil to fill plug hole until oil flows out of the check plug hole. For recommended oil, see Maintenance—Machine. (Section 3-1.)

Specification

Hydrostatic Planetary Gear Case Oil (S.N. —192141)—Capacity	
(per side).....	0.55 L 18.6 oz.

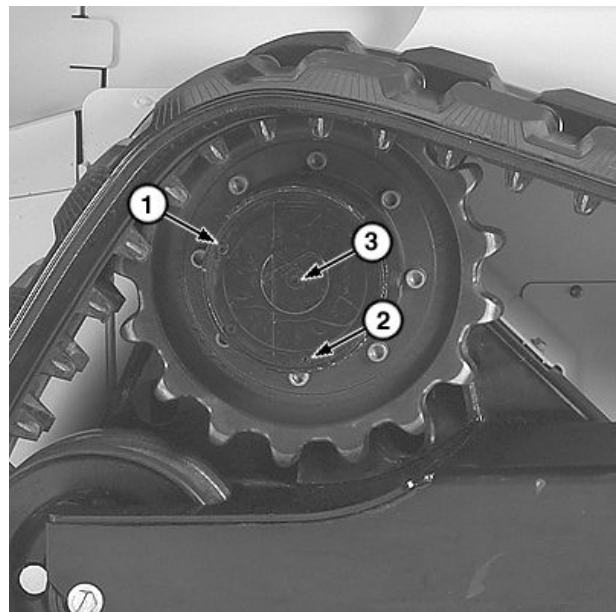

Hydrostatic Planetary Gear Case (S.N. —192141)

1— Fill Plug
2— Drain Plug

3— Check Plug

9. Install check and fill plugs.

ER79617,0000C42 -19-22OCT10-1/1

TX1065774A —UN—13OCT09

Maintenance—Every 250 Hours

Take Engine Oil Sample

See your authorized dealer.

OUT4001.000039B -19-14MAR12-1/1

Maintenance—Every 500 Hours

Change Engine Oil and Replace Filter

1. Park machine.
2. Run engine a few minutes to warm oil.
3. Engage park brake and stop engine.
4. On right side of machine, remove two outer cap screws (2) from access cover (1) and pull out cover with attached engine oil drain hose.
5. Place suitable container under hose plug (3). Remove hose plug using two wrenches to avoid twisting hose. Allow oil to drain into container. Dispose of waste oil properly.

NOTE: Make sure O-ring is still intact when installing hose plug.

6. After oil is drained, install hose plug.
7. Open engine cover and remove right engine side panel.
8. Clean dirt or debris from around engine oil filter (4).
9. Place suitable container under drip tray below the engine oil filter.
10. To remove oil filter, turn filter counterclockwise using a filter wrench.
11. Allow excess oil to drain into container. Dispose of old filter and waste oil properly.
12. Apply a film of clean engine oil on seal of new filter.
13. Install filter. Turn filter until seal contacts mounting surface. Then turn filter by hand 2/3 to 1 turn more.

1— Access Cover
2— Cap Screw (2 used)

3— Hose Plug
4— Engine Oil Filter

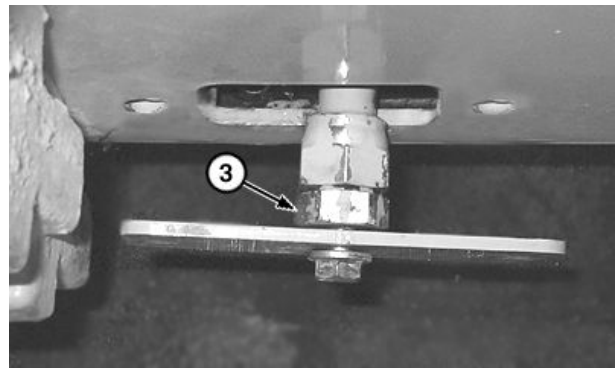
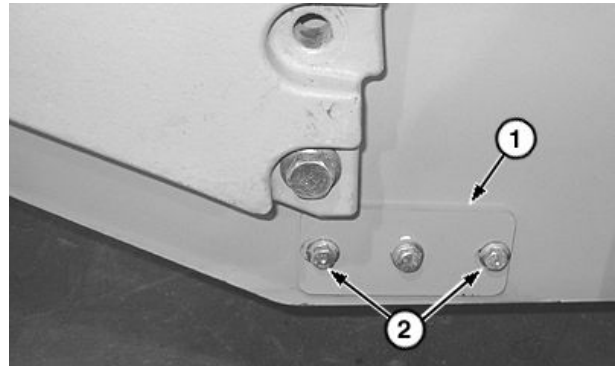

Boom Raised for Picture Clarity

Continued on next page

OUT4001,00004C0 -19-10NOV09-1/2

TX1065666A—UN—06OCT09

TX1065667A—UN—10NOV09

TX1065671A—UN—06OCT09

14. Remove engine oil fill cap (5).

IMPORTANT: Do not overfill. If overfilled, oil can cause engine damage.

15. Add oil. For recommended oil, see Diesel Engine Oil. (Section 3-1.)

Specification

Engine—Oil Capacity	
With Filter.....	9.0 L
	2.4 gal

16. Check engine oil level on dipstick (6).

17. Install and tighten fill cap.

18. Start engine, and run at slow speed for 2 minutes. Check for leaks around filter and drain plug.

19. Check engine oil level on dipstick again.

20. Push in access cover and install cap screws.

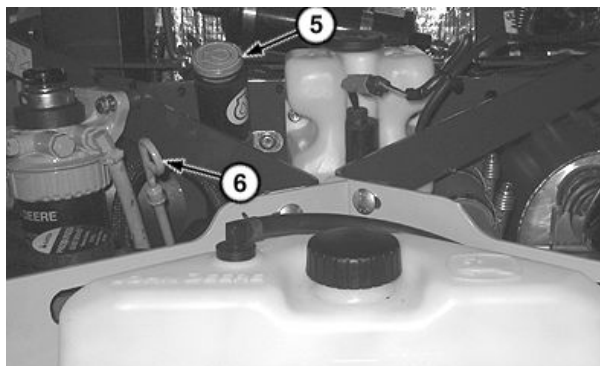

5— Engine Oil Fill Cap

6— Dipstick

21. Install right engine side panel and close engine cover.

OUT4001,00004C0 -19-10NOV09-2/2

TX1065673A—UN—06OCT09

Replace Fuel Filter and Water Separator

1. Park machine.

2. Raise boom and lock in raised position.

3. Stop engine and engage park brake.

4. Open engine cover and remove left engine side panel.

5. Place a suitable container under drain valve (2) of fuel filter and water separator (1).

6. Loosen drain valve to drain water, sediment and fuel from filter into a container. Dispose of waste properly.

7. Rotate fuel filter and water separator counterclockwise to remove.

8. Fill new fuel filter and water separator with fuel.

9. Install by aligning location tabs and pushing up to seat filter and tighten.

10. Install left engine side panel and close engine cover.

11. Lower boom.

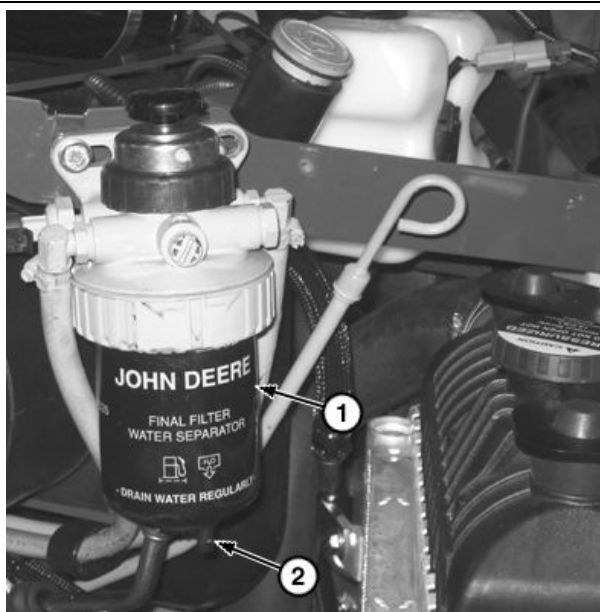

1— Fuel Filter and Water Separator

2— Drain Valve

OUT4001,00004C1 -19-11APR11-1/1

TX1065525A—UN—10OCT09

Replace In-Line Fuel Filter

1. Park machine.
2. Raise boom and lock in raised position.
3. Stop engine and engage park brake.
4. Open engine cover and remove left engine side panel.
5. Loosen and slide hose clamps away from in-line fuel filter (1). Remove hoses from filter.
6. Dispose of old fuel filter properly.
7. Install new filter to hoses. Make sure that the fuel hose coming from the tank is attached to the end of the filter marked with IN.
8. Tighten clamps.
9. Install left engine side panel and close engine cover.
10. Lower boom.

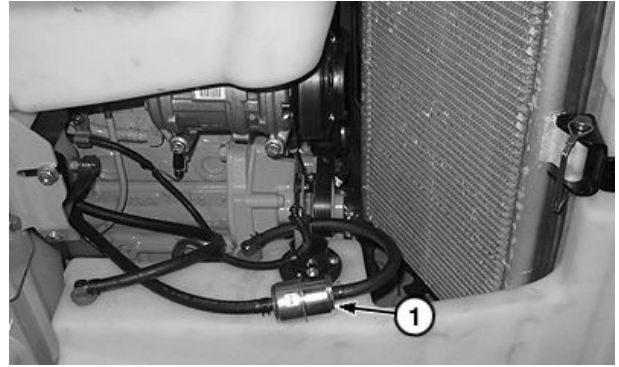

1— In-Line Fuel Filter

TX106572A —UN—070CT09

OUT4001,00004C3 -19-12NOV09-1/1

Replace Primary Engine Air Filter

IMPORTANT: Prevent possible engine damage. Do not clean primary engine air filter. Replace it when air restriction light is illuminated on engagement and monitor unit (EMU). To prevent dirt from being sucked into engine, do not remove filter when engine is running.

Do not start engine without both the primary and secondary filters installed.

1. Park machine.
2. Raise boom and lock in raised position.
3. Stop engine and engage park brake.
4. Open engine cover and remove left engine side panel.
5. Remove the dust unloader valve (3) and clean out any dust found in the drop tube.
6. Install dust unloader valve or replace if found worn or damaged.
7. Unhook service cover latches (1) and remove service cover.
8. To remove the primary filter (2), press and rotate the filter counterclockwise until free.
9. Gently pull the filter out of housing and discard. Avoid dislodging contaminant from the filter or knocking it against the housing.
10. Remove the secondary filter (4) by pulling it straight out. This allows necessary access to properly clean the primary filter's seal surface.
11. Inspect the seal surface and housing for any damage. Replace the entire air cleaner if damage is present.
12. Block the outlet tube of the air cleaner using a small dampened towel prior to proceeding with cleaning the seal surface to avoid contaminating the induction system.
13. With a second small dampened towel, thoroughly clean the inside surface of the housing and seal areas. Be careful not to introduce contaminant into the outlet tube.
14. Inspect the new primary filter carefully. Check for any voids, cuts, tears, or indentations in the urethane-sealing surfaces.
15. Remove the dampened towel from the outlet tube that was used to protect the induction system during servicing.
16. Install the secondary filter by pressing it firmly in place until seated. When properly fitted it should fit snugly inside the outlet tube.
17. Install the new primary filter by sliding it over the secondary filter, pressing, and rotating the filter clockwise until fully fitted against the stop.

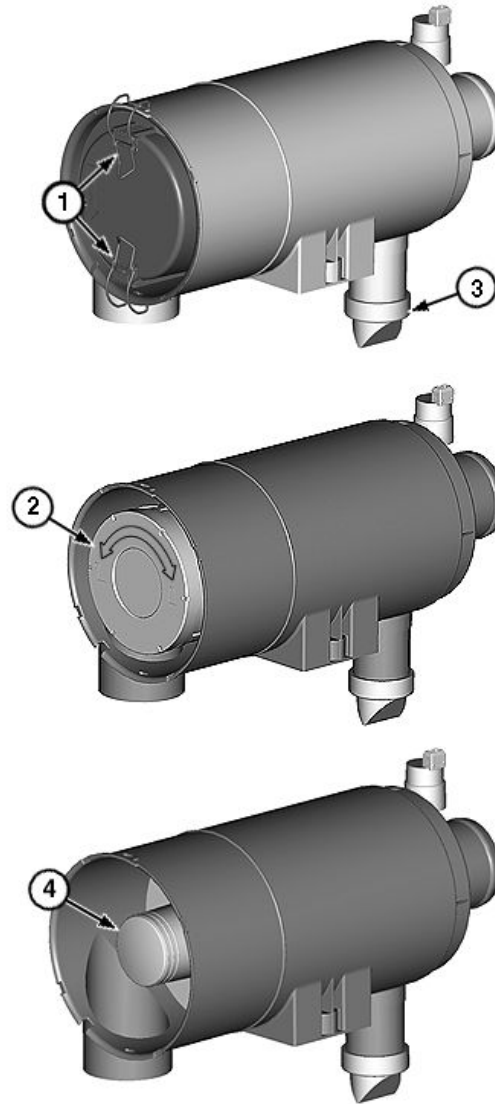

1—Service Cover Latch (2 used)
2—Primary Filter

3—Dust Unloader Valve
4—Secondary Filter

IMPORTANT: Prevent possible engine damage. If the service cover does not fit flush to the body, the primary filter is not properly seated in the housing. Check the primary and secondary filter installation, following the proper installation procedure so they become fully seated. The service cover will then go on easily. Using the service cover to push the filters could cause damage to the housing and will void the warranty.

18. Install service cover, with the INLET arrow lined up with the air cleaner inlet. Do not force the service cover onto the air cleaner. It should go on with no extra force

Continued on next page

MB60223,0000226 -19-20JAN11-1/2

TX1086273A—UN—06JAN11

TX1086610A—UN—06JAN11

TX1086647A—UN—06JAN11

19. Fasten latches to secure the service cover and make sure that latches penetrate the slots in both the body and the service cover.
20. Inspect and torque all clamps, bolts and connections in the entire air intake system. Check for holes in piping, and repair if needed.
21. Start engine and check monitor for the air filter restriction indicator light to be sure there is no restriction.

- If air restriction indicator still shows restriction, replace secondary filter.

22. Install left engine side panel and close engine cover.
23. Lower boom.

MB60223,0000226 -19-20JAN11-2/2

Replace Hydraulic Oil Reservoir Breather

1. Park machine.
2. Raise operator's station. See Raising Operator's Station. (Section 3-2.)
3. Loosen and slide hose clamp away from hydraulic oil reservoir breather (1). Remove hose.
4. Remove breather.
5. Install new breather.
6. Install hose and tighten clamp.
7. Lower operator's station.

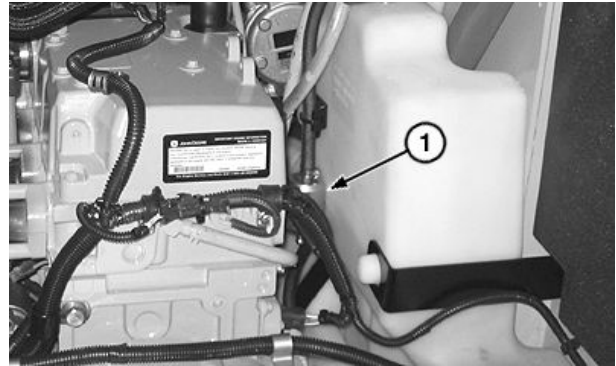

TX1065732A—UN—10NOV09

1— Hydraulic Oil Reservoir Breather

OUT4001,00004C5 -19-10NOV09-1/1

Replace Hydraulic Oil Filter

1. Park machine.
2. Raise boom and lock in raised position.
3. Stop engine and engage park brake.
4. Open engine cover and remove right engine side panel.
5. Turn hydraulic oil filter (1) with a filter wrench to remove.
6. Put a film of clean hydraulic oil on seal of new filter.
7. Install filter until it contacts mounting surface. Tighten filter by hand 2/3 to 1 turn more.
8. Install right engine side panel and close engine cover.

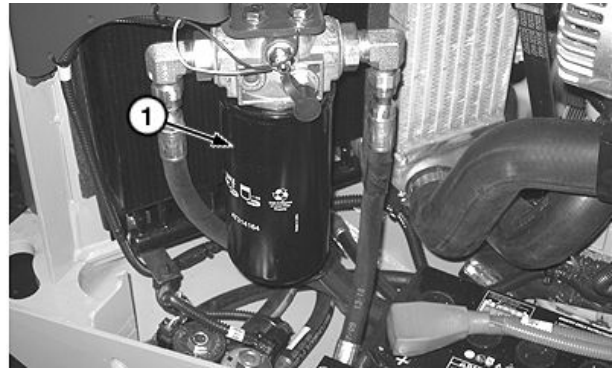

TX1065733A—UN—07OCT09

1— Hydraulic Oil Filter

OUT4001,00004C6 -19-04DEC09-1/1

Lubricate Steering Linkage—If Equipped

1. Raise operator's station. See Raising Operator's Station. (Section 3-2.)
2. Lubricate universal driveshaft grease fittings (1) and steering arm grease fittings (2) with one or two shots of grease. For recommended grease, see Grease. (Section 3-1.)
3. Lower operator's station.

1— Universal Driveshaft
Grease Fitting (2 used)

2— Steering Arm Grease Fitting
(2 used)

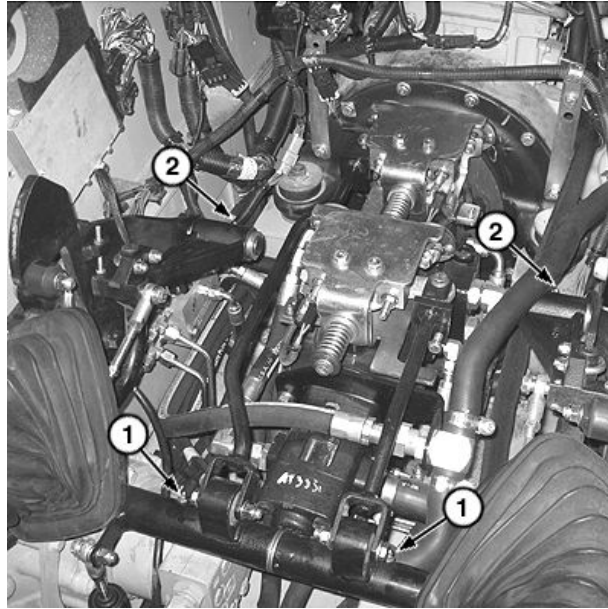

TX1065735A—UN—09OCT09

OUT4001,00004C8 -19-14OCT09-1/1

Drain Fuel Tank Sump

1. Remove cap screws from access panel under rear of machine and remove access panel.

NOTE: If machine is equipped with a bucket, dump the bucket slightly to raise front end off the ground. Shut the engine OFF.

2. To ensure that all of the water drains properly, use suitable lifting device to slightly lift the front of the machine off of the ground. Place blocks under front of tracks to support the machine.

⚠ CAUTION: Handle fuel carefully. Make sure the engine is OFF. Be prepared to catch fuel with suitable container when drain plug is removed.

3. Remove fuel tank sump drain plug (1) and drain water and sediment into a suitable container. Dispose of waste properly.

NOTE: For a list of approved thread sealants contact your authorized dealer.

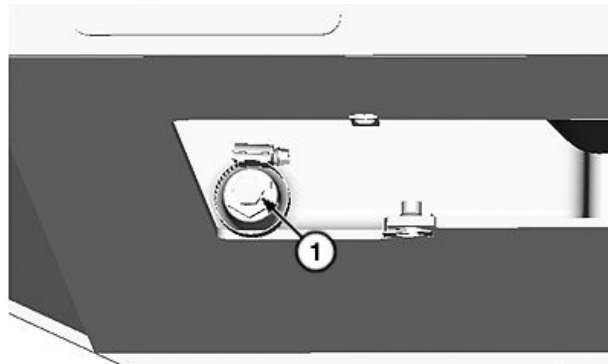

View Shown From Under Machine

1— Fuel Tank Sump Drain Plug

4. Apply thread sealant to threads of drain plug.
5. Install drain plug.
6. Install access panel and cap screws.

TX1065763A—UN—14OCT09

OUT4001,000051A -19-21MAY13-1/1

Change Hydrostatic Planetary Gear Case Oil (S.N. —192141)

1. Park the machine on a level surface until drain plug (2) is at the bottom of gear case.
2. Stop engine.

⚠ CAUTION: High-pressure release of fluids from a pressurized system can cause serious burns. Wait for hydrostatic planetary gear case oil to cool. Keep body and face away from check plug. Gradually loosen fill plug to release pressure.

3. Allow machine to cool. Slowly loosen the fill plug (1) to release pressure.
4. Remove drain plug. Allow oil to drain into a container. Dispose of waste properly.
5. Install drain plug.
6. Remove fill plug completely.
7. Remove check plug (3).
8. Add oil to fill plug hole until oil flows out of the check plug hole. For recommended oil, see Maintenance—Machine. (Section 3-1.)

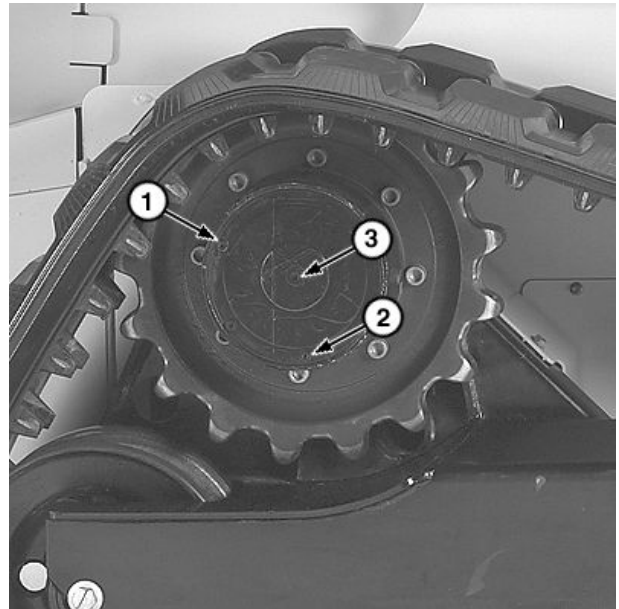

Hydrostatic Planetary Gear Case (S.N. —192141)

1— Fill Plug
2— Drain Plug

3— Check Plug

9. Install check and fill plugs.

Specification

Hydrostatic Planetary Gear Case Oil (S.N. —192141)—Capacity (per side).....	0.55 L
	18.6 oz.

ER79617,0000C43 -19-22OCT10-1/1

TX106574A —UN—13OCT09

Take Fluid Samples

See your authorized dealer for taking the following fluid samples:

- Hydraulic Oil

- Diesel Fuel
- Coolant
- Hydrostatic Planetary Gear Case Oil

OUT4001,0000531 -19-11OCT10-1/1

Maintenance—Every 1000 Hours

Check Coolant

See Check Coolant. (Section 3-3.)

OUT4001,0000365 -19-12APR11-1/1

Replace Secondary Engine Air Filter

IMPORTANT: Prevent possible engine damage. Do not clean primary engine air filter. Replace it when air restriction light is illuminated on engagement and monitor unit (EMU). To prevent dirt from being sucked into engine, do not remove filter when engine is running.

Do not start engine without both the primary and secondary filters installed.

1. Park machine.
2. Raise boom and lock in raised position.
3. Stop engine and engage park brake.
4. Open engine cover and remove left engine side panel.
5. Remove the dust unloader valve (3) and clean out any dust found in the drop tube.
6. Install dust unloader valve or replace if found worn or damaged.
7. Unhook service cover latches (1) and remove service cover.
8. To remove the primary filter (2), press and rotate the filter counterclockwise until free.
9. Gently pull the filter out of housing and discard. Avoid dislodging contaminant from the filter or knocking it against the housing.
10. Remove the secondary filter (4) by pulling it straight out.
11. Inspect the seal surface and housing for any damage. Replace the entire air cleaner if damage is present.
12. Block the outlet tube of the air cleaner using a small dampened towel prior to proceeding with cleaning the seal surface to avoid contaminating the induction system.
13. With a second small dampened towel, thoroughly clean the inside surface of the housing and seal areas. Be careful not to introduce contaminant into the outlet tube.
14. Inspect the new secondary filter carefully. Check for any voids, cuts, tears, or indentations in the urethane-sealing surfaces.
15. Remove the dampened towel from the outlet tube that was used to protect the induction system during servicing.
16. Install the new secondary filter by pressing it firmly in place until seated. When properly fitted it should fit snugly inside the outlet tube.
17. Install the primary filter by sliding it over the secondary filter, pressing, and rotating the filter clockwise until fully fitted against the stop.

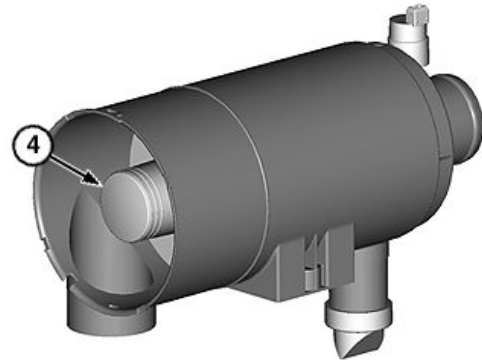
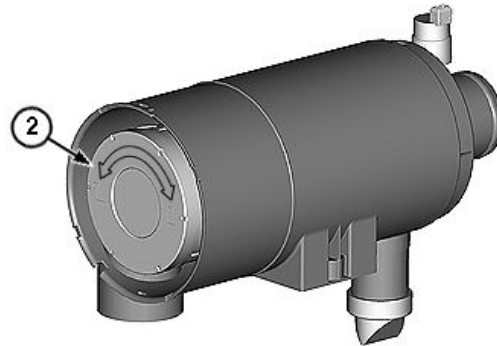
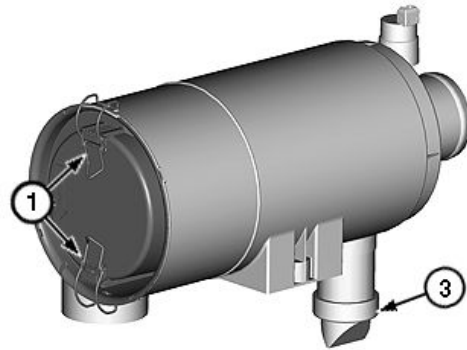

1—Service Cover Latch (2 used)
2—Primary Filter

3—Dust Unloader Valve
4—Secondary Filter

IMPORTANT: Prevent possible engine damage. If the service cover does not fit flush to the body, the primary filter is not properly seated in the housing. Check the primary and secondary filter installation, following the proper installation procedure so they become fully seated. The service cover will then go on easily. Using the service cover to push the filters could cause damage to the housing and will void the warranty.

18. Install service cover, with the INLET arrow lined up with the air cleaner inlet. Do not force the service cover onto the air cleaner. It should go on with no extra force

TX1086273A —UN—06JAN11

TX1086610A —UN—06JAN11

TX1086647A —UN—06JAN11

- 19. Fasten latches to secure the service cover and make sure that latches penetrate the slots in both the body and the service cover.
- 20. Inspect and torque all clamps, bolts and connections in the entire air intake system. Check for holes in piping, and repair if needed.

- 21. Start engine and check monitor for the air filter restriction indicator light to be sure there is no restriction.
- 22. Install left engine side panel and close engine cover.
- 23. Lower boom.

MB60223.0000224 -19-13JAN11-2/2

Change Hydrostatic Planetary Gear Case Oil (S.N. 192142—)

- 1. Park the machine on a level surface until drain plug (2) is at the bottom of gear case.
- 2. Stop engine.

CAUTION: High-pressure release of fluids from a pressurized system can cause serious burns. Wait for hydrostatic planetary gear case oil to cool. Keep body and face away from check plug. Gradually loosen fill plug to release pressure.

- 3. Allow machine to cool. Slowly loosen the fill plug (1) to release pressure.
- 4. Remove drain plug. Allow oil to drain into a container. Dispose of waste properly.
- 5. Install drain plug.
- 6. Remove fill plug completely.
- 7. Remove check plug (3).
- 8. Add oil to fill plug hole until oil flows out of the check plug hole. For recommended oil, see Maintenance—Machine. (Section 3-1.)

Specification

Hydrostatic Planetary
Gear Case Oil (S.N.
192142—)—Capacity
(per side)..... 0.79 L
27.0 oz.

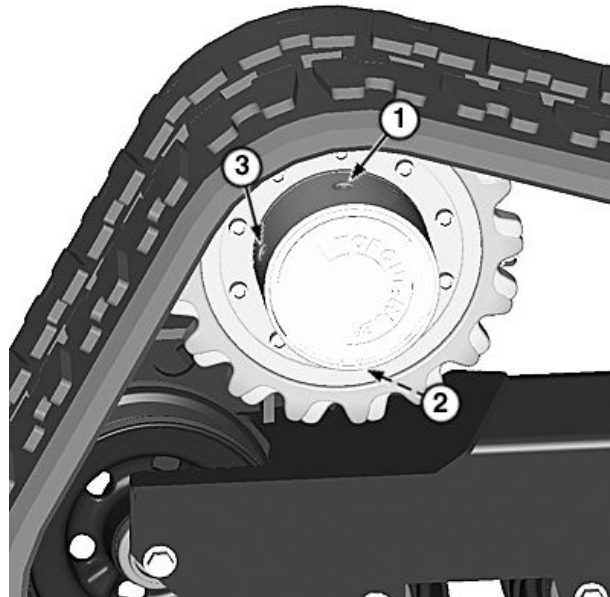

Hydrostatic Planetary Gear Case (S.N. 192142—)

- 1— Fill Plug
- 2— Drain Plug
- 3— Check Plug

- 9. Install check and fill plugs.

TX1081205A—UN—24AUG10

ER79617.0000C2C -19-22OCT10-1/1

Change Hydraulic Reservoir Oil

IMPORTANT: To ensure an accurate reading, park machine on smooth level ground and check level only when hydraulic oil is cold and boom is down with boom and bucket cylinders fully retracted.

When adding oil to the hydraulic reservoir, be careful not to get dirt into reservoir or oil.

Do not overfill hydraulic oil reservoir. An overfilled hydraulic oil reservoir will not allow for oil expansion, which may result in oil leakage past hydraulic reservoir breather or fill cap.

1. Park machine.
2. Open engine cover and remove left engine side panel.
3. Remove hydraulic reservoir fill cap (3).
4. Under machine, remove hydraulic reservoir drain plug cover (1).
5. Position a suitable container under hydraulic reservoir drain plug (2).
6. Remove drain plug and drain oil. Dispose of waste oil properly.
7. Install drain plug and cover.
8. Fill hydraulic oil reservoir. For recommended hydraulic oil, see Hydraulic and Hydrostatic Oil. (Section 3-1.)

Specification

Hydraulic Reservoir	
Oil—Capacity.....	19.0 L 5.0 gal

9. Check hydraulic reservoir oil level on sight glass (4). Oil level should be between the two arrows.
10. Inspect drain plug for leakage.
11. Install hydraulic reservoir fill cap.
12. Install left engine side panel and close engine cover.



View Shown From Under Machine

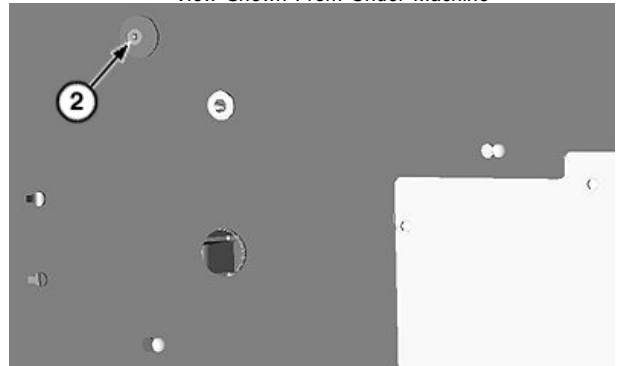

View Shown From Under Machine

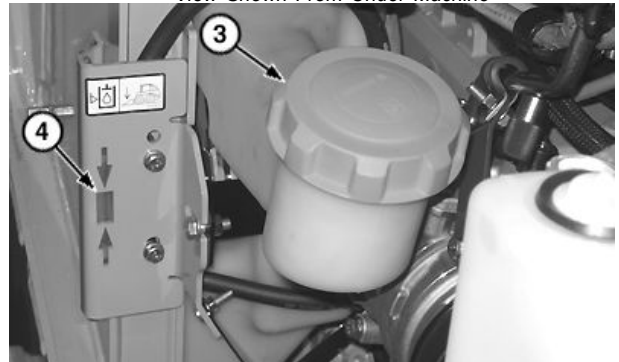

- | | |
|---|----------------|
| 1— Hydraulic Reservoir Drain Plug Cover | 3— Fill Cap |
| 2— Hydraulic Reservoir Drain Plug | 4— Sight Glass |

TX1065772A —UN—09OCT09

TX1065773A —UN—09OCT09

TX1065778A —UN—08OCT09

OUT4001,00004CC -19-13NOV09-1/1

Maintenance—Every 6000 Hours

Drain Cooling System

⚠ CAUTION: Explosive release of fluids from pressurized cooling system can cause serious burns.

Prevent possible injury from hot spraying water. Shut off engine. Remove filler cap only when cool enough to touch with bare hands. Slowly loosen cap to first stop to relieve pressure before removing completely.

1. Park machine.
2. Allow engine to cool.
3. Open engine cover and remove right and left engine side panels.
4. Slowly remove radiator cap (1).
5. On right side of machine, remove two outer cap screws from access cover (2) and pull out access cover.
6. Route coolant drain hose (3) through access cover opening. Place suitable container under drain hose.
7. On left side of machine, open radiator drain valve (4) and allow coolant to drain into container. Dispose of used coolant properly.
8. After coolant has drained, close radiator drain valve.

1—Radiator Cap
2—Access Cover

3—Coolant Drain Hose
4—Radiator Drain Valve

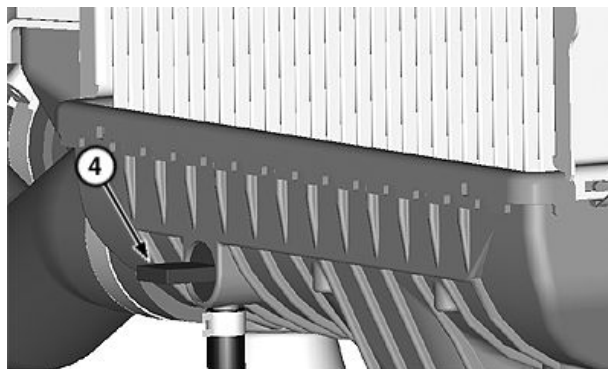
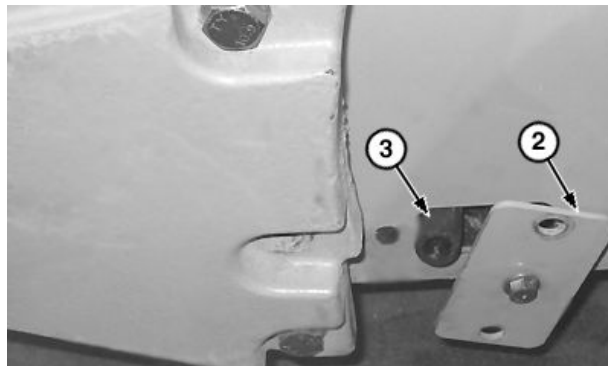

TX1065436A—UN—02OCT09

TX1065788A—UN—10NOV09

TX1065789A—UN—10NOV09

OUT4001,00004DE -19-21FEB13-1/1

Flush Cooling System

CAUTION: Prevent possible injury from hot spraying water. Shut off engine. Remove filler cap only when cool enough to touch with bare hands. Slowly loosen cap to first stop to relieve pressure before removing completely.

IMPORTANT: To prevent engine damage:

- Do not pour water into a hot engine.
- Do not operate engine without coolant.

1. Fill cooling system with clean water and John Deere Cooling System Cleaner, John Deere Cooling System Quick Flush. Follow directions on the can.
2. Install and tighten radiator cap.
3. Start and run engine until it reaches operating temperature.
4. Stop engine.
5. Place suitable container under drain hose.

CAUTION: Engine and flushing solution will be hot. Avoid contact with skin to prevent serious burns.

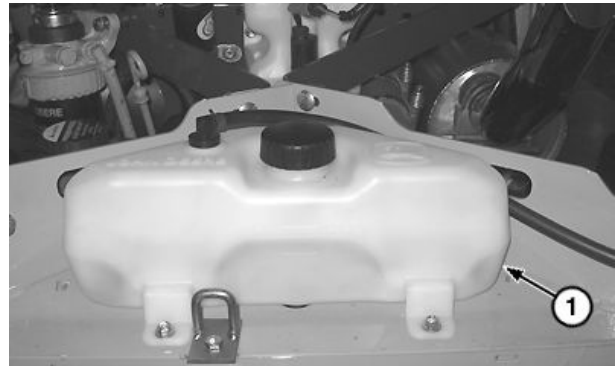

1— Overflow Tank

6. Drain cooling system immediately before rust and dirt settle. Slowly remove radiator cap and open radiator drain valve. Allow flushing solution to drain into container. Dispose of waste properly.
7. Close radiator drain valve.
8. Remove overflow tank (1) and overflow hose.
9. Clean and install overflow tank and overflow hose.

TX1065796A—UN—08OCT09

OUT4001,00004DF -19-21FEB13-1/1

Fill Cooling System

CAUTION: Prevent possible injury from hot spraying water. Shut off engine. Remove filler cap only when cool enough to touch with bare hands. Slowly loosen cap to first stop to relieve pressure before removing completely.

IMPORTANT: Prevent possible machine damage. Using incorrect coolant mixture can damage radiator.

- Do not operate engine without coolant.
- Do not operate engine with plain water.
- Use antifreeze approved for use in aluminum engines.
- Do not exceed a 50% antifreeze mixture for coolant.
- Do not pour coolant or water into radiator when engine is hot.

NOTE: John Deere COOL-GARD™ II Pre-Mix coolant is recommended when adding new coolant to cooling system.

Follow directions on container for correct mixture ratio.

COOL-GARD is a trademark of Deere & Company

1. Check condition of coolant system hoses. If new hoses are needed, see your authorized dealer.
2. Fill cooling system slowly.

Specification

Cooling System—Capacity.....	9.3 L
	2.5 gal

3. Install and tighten radiator cap.
4. Start engine and run until engine reaches operating temperature, allowing entire system to be filled with coolant.
5. Stop engine.
6. Allow engine to cool.
7. Check overflow tank for coolant level. Coolant should be above the MIN COLD line, but below the MAX COLD line.

OUT4001,00004E0 -19-21FEB13-1/1

Miscellaneous—Machine

Do Not Service Control Valves, Cylinders, Pumps, or Motors

Special tools and information are needed to service control valves, cylinders, pumps, or motors.

If these parts need service, see your authorized John Deere dealer.

TX,90,DH2537 -19-20JUL12-1/1

Precautions for Alternator and Regulator

When batteries are connected, follow these rules:

1. Disconnect negative (-) battery cable when you work on or near alternator or regulator.
2. DO NOT TRY TO POLARIZE ALTERNATOR OR REGULATOR.
3. Be sure alternator wires are correctly connected BEFORE you connect batteries.
4. Do not ground alternator output terminal.
5. Do not disconnect or connect any alternator or regulator wires while batteries are connected or while alternator is operating.
6. Connect batteries or a booster battery in the correct polarity (positive [+] to positive [+] and negative [-] to negative [-]).
7. Do not disconnect the batteries when engine is running and alternator is charging.
8. Disconnect battery cables before you connect battery charger to the batteries. If machine has more than one battery, each battery must be charged separately.

CED,OUO1021,185 -19-05NOV08-1/1

Check Battery Electrolyte Level and Terminals

⚠ CAUTION: Battery gas can explode. Keep sparks and flames away from batteries. Use a flashlight to check battery electrolyte level.

NEVER check battery charge by placing a metal object across the posts. Use a voltmeter or hydrometer.

ALWAYS remove grounded (-) battery clamp first, and replace it last.

Sulfuric acid in battery electrolyte is poisonous. It is strong enough to burn skin, eat holes in clothing, and cause blindness if splashed into eyes.

Avoid the hazard by:

1. Filling batteries in a well-ventilated area.
2. Wearing eye protection and rubber gloves.
3. Avoiding breathing fumes when electrolyte is added.
4. Avoiding spilling or dripping electrolyte.
5. Use proper jump start procedure.

If you spill acid on yourself:

1. Flush contacted skin with water.
2. Apply baking soda or lime to contacted area to help neutralize the acid.
3. Flush eyes with water for 15—30 minutes. Get medical attention immediately.

If acid is swallowed:

1. Do not induce vomiting.

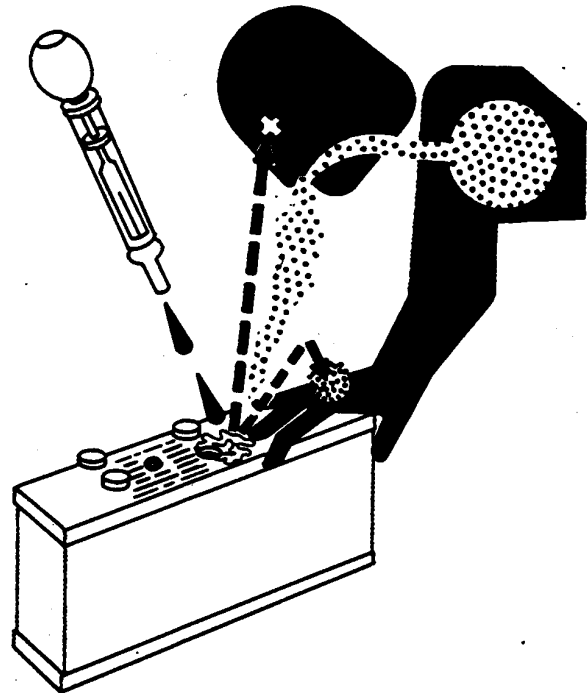

2. Drink large amounts of water or milk, but do not exceed 1.9 L (2 qt).
3. Get medical attention immediately.

1. Remove battery box cover.

Continued on next page

TX14740,0001CBE -19-04NOV09-1/3

TS203—UN—23AUG88

IMPORTANT: If water is added to batteries during freezing weather, batteries must be charged after water is added to prevent batteries from freezing. Charge battery using a battery charger or by running the engine.

2. Fill each cell to within specified range with distilled water. DO NOT overfill.

CAUTION: Prevent possible injury. ALWAYS remove grounded (-) battery clamp first, and replace it last.

3. Disconnect battery clamps, grounded clamp first.

1— Battery Post
2— Fill Tube

3— Electrolyte Level Range

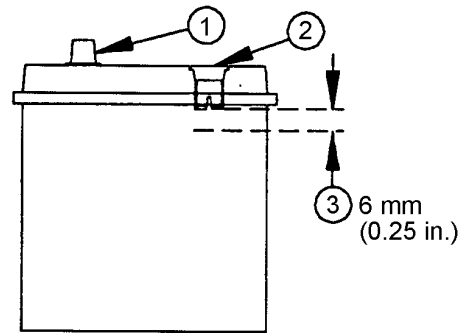

T137535—UN—25JAN01

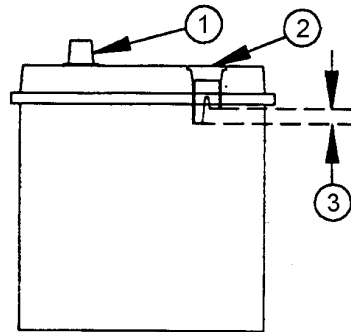

T137536—UN—25JAN01

TX14740,0001CBE -19-04NOV09-2/3

4. Clean battery terminals (1) and clamps with a stiff brush.
5. Apply lubricating grease (2) around battery terminal base only.
6. Install and tighten clamps, grounded clamp last.

1— Battery Terminal

2— Lubricating Grease

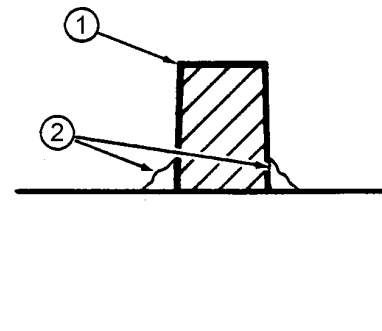

T137537—UN—25JAN01

TX14740,0001CBE -19-04NOV09-3/3

Handling, Checking, and Servicing Batteries Carefully

CAUTION: Battery gas can explode. Keep sparks and flames away from batteries. Use a flashlight to check battery electrolyte level.

Never check battery charge by placing a metal object across the posts. Use a voltmeter or hydrometer.

Always remove grounded (-) battery clamp first, and replace it last.

Sulfuric acid in battery electrolyte is poisonous. It is strong enough to burn skin, eat holes in clothing, and cause blindness if splashed into eyes.

Avoid the hazard by:

1. Filling batteries in a well-ventilated area.
2. Wearing eye protection and rubber gloves.
3. Avoiding breathing fumes when electrolyte is added.
4. Avoiding spilling or dripping electrolyte.
5. Use proper jump start procedure.

If you spill acid on yourself:

1. Flush contacted skin with water.
2. Apply baking soda or lime to contacted area to help neutralize the acid.
3. Flush eyes with water for 15—30 minutes. Get medical attention immediately.

If acid is swallowed:

1. Do not induce vomiting.
2. Drink large amounts of water or milk, but do not exceed 1.9 L (2 qts.).
3. Get medical attention immediately.

WARNING: Battery posts, terminals, and related accessories contain lead and lead compounds, chemicals known to the State of California to cause cancer and reproductive harm. **Wash hands after handling.**

If electrolyte spills on the floor, use one of the following mixtures to neutralize the acid: 0.5 kg (1 lb.) baking soda in 4 L (1 gal.) water, or 0.47 L (1 pt.) household ammonia in 4 L (1 gal.) water.

IMPORTANT: Do not overfill the battery cells.

Check the specific gravity of electrolyte in each battery cell.

See your authorized dealer for JT05460 SERVICEGARD™ battery and coolant tester. Follow directions included with the tester.

A fully charged battery will have a corrected specific gravity reading of 1.260. If the reading is below 1.200, charge the battery.

SERVICEGARD is a trademark of Deere & Company



Exploding Battery Gas

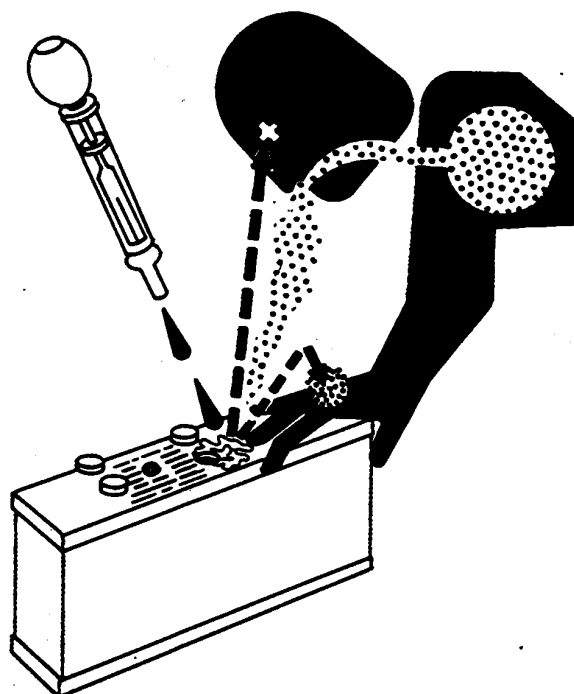

Battery Electrolyte



Battery and Coolant Tester

TS204—UN—15APR13

TS203—UN—23AUG88

T85402—UN—10NOV88

TX03679,0001788 -19-05MAR13-1/1

Using Battery Charger

CAUTION: Prevent possible injury from exploding battery. Do not charge a battery if the battery is frozen or it may explode. Warm battery to 16°C (60°F) before charging.

Turn off charger before connecting or disconnecting it.

IMPORTANT: Do not use battery charger as a booster if a battery has a 1.150 specific gravity reading or lower.

Disconnect battery ground (-) clamp before you charge batteries in the machine to prevent damage to electrical components.

A battery charger may be used as a booster to start engine.

Ventilate the area where batteries are being charged.

Stop or cut back charging rate if battery case feels hot, or is venting electrolyte. Battery temperature must not exceed 52°C (125°F).



Prevent Battery Explosions

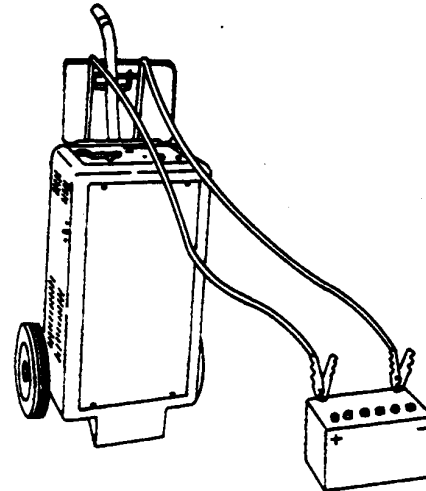

Charger

TS204—UN—15APR13

N36890—UN—07OCT88

OUT4001,0000239 -19-03JAN12-1/1

Using Booster Batteries—12-Volt System

Before boost starting, machine must be properly shut down to prevent unexpected machine movement when engine starts.

CAUTION: Prevent possible injury from exploding battery. An explosive gas is produced while batteries are in use or being charged. Keep flames or sparks away from the battery area. Make sure the batteries are charged in a well ventilated area.

IMPORTANT: The machine electrical system is a 12-volt negative (-) ground. Use only 12-volt booster batteries.

1. Connect one end of the positive cable to the positive terminal of the machine batteries and the other end to the positive terminal of the booster batteries.
2. Connect one end of the negative cable to the negative terminal of the booster batteries. Connect other end of the negative cable to the machine as far away from the machine batteries as possible.
3. Start engine.
4. Immediately after starting engine disconnect end of the negative cable from the machine. Then disconnect the other end of the negative cable from the negative terminal of the booster batteries.
5. Disconnect positive cable from booster batteries and machine batteries.



Using Booster Batteries

TS204—UN—15APR13

OUT4001,00000E1 -19-12JUL13-1/1

Removing Battery

- ⚠ CAUTION: Battery gas can explode:**
 Keep sparks and flames away from batteries. Use a flashlight to check battery electrolyte level.
 Never check battery charge by placing a metal object across the posts.
 Always remove grounded (-) battery clamp first, and replace it last.

NOTE: If battery is dead, battery will need to be jumped before removal procedure so the boom can be raised.

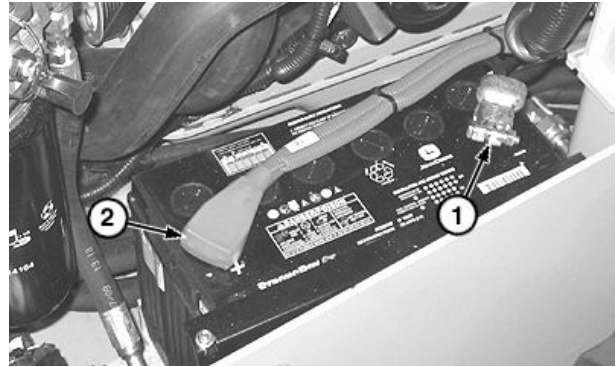

TX1065965A—UN—12OCT09

1. Remove any attachment.
2. Park machine.
3. Raise boom and lock in raised position.
4. Stop engine and engage park brake.
5. Open engine cover and remove right engine side panel.
6. Disconnect negative (-) cable (1) from battery.
7. Pull back red positive terminal cover (2) and disconnect positive (+) cable.
8. Clean battery with a damp cloth or rag. Keep dirt out of battery cells.
9. Remove battery:
 - Loosen J-bolts on battery hold down bracket.
 - Lift battery from battery compartment.
10. Clean battery, battery terminals, cable ends, battery box, and other parts with a solution of 1 part baking soda to 4 parts water. Keep solution out of battery cells.
11. Rinse all parts with clean water and let dry.

1— Negative (-) Cable 2— Positive Terminal Cover

NOTE: If a new battery is needed, install a battery of equal specification. See Replacing Battery in this section.

12. Install battery:
 - Place battery in battery compartment.
 - Install battery hold down bracket by inserting in rear frame slot.
 - Install J-bolts, and tighten hardware.
13. Connect positive (+) cable to battery positive (+) terminal. Apply petroleum or silicone spray to terminal to prevent corrosion. Make sure connection is tight. Push red positive cover over positive terminal.
14. Connect negative (-) cable to battery. Apply petroleum jelly or silicone spray to prevent corrosion. Make sure connection is tight.
15. Install right engine side panel and close engine cover.
16. Lower boom.

OUT4001,00004EC -19-28OCT09-1/1

Replacing Battery

This machine has one 12-volt battery with negative (-) ground. Battery must meet one of the specifications below.

Specification	
Battery—Cold Cranking	
Amps.....	750

Battery—Minutes	
Reserve Capacity.....	150

For removal and installation procedure, see Removing Battery in this section.

OUT4001,00004ED -19-12OCT09-1/1

Welding On Machine

IMPORTANT: Disconnect both negative and positive battery cables and microprocessor unit (if applicable).

Have only a qualified welder do this job.
Connect welder ground clamp close to each

weld area so electrical current does not pass through any bearings.

Remove or protect all parts that can be damaged by heat or weld splatter.

VD76477,00004EE -19-31OCT12-1/1

Welding Near Electronic Control Units

IMPORTANT: Do not jump-start engines with arc welding equipment. Currents and voltages are too high and may cause permanent damage.

1. Disconnect the negative (-) battery cable(s).
2. Disconnect the positive (+) battery cable(s).
3. Connect the positive and negative cables together. Do not attach to vehicle frame.
4. Clear or move any wiring harness sections away from welding area.
5. Connect welder ground close to welding point and away from control units.



TS953 —JUN—15MAY90

6. After welding, reverse Steps 1—5.

DX,WW,ECU02 -19-14AUG09-1/1

Keep Electronic Control Unit Connectors Clean

IMPORTANT: Do not open control unit and do not clean with a high-pressure spray. Moisture, dirt, and other contaminants may cause permanent damage.

1. Keep terminals clean and free of foreign debris. Moisture, dirt, and other contaminants may cause the terminals to erode over time and not make a good electrical connection.

2. If a connector is not in use, put on the proper dust cap or an appropriate seal to protect it from foreign debris and moisture.
3. Control units are not repairable.
4. Since control units are the components LEAST likely to fail, isolate failure before replacing by completing a diagnostic procedure. (See your John Deere dealer.)
5. The wiring harness terminals and connectors for electronic control units are repairable.

DX,WW,ECU04 -19-11JUN09-1/1

Remove and Install Halogen Bulbs

1. Remove torx screws (1) and pull out lamp housing (2) from machine.
2. Disconnect harness connector (3).
3. Release retainer clip (4) to remove halogen bulb (5) from lamp.
4. Disconnect halogen bulb from connector (6).

IMPORTANT: Do not touch the halogen bulb with bare hands. Oil and moisture may cause premature bulb failure. Clean bulb glass if touched, using an oil-free cloth with alcohol.

5. Connect new halogen bulb and install into lamp.
6. Install retainer clip.
7. Connect harness connector and install lamp housing back into machine.
8. Install torx screws.

1— Screw (4 used)
2— Lamp Housing
3— Harness Connector

4— Retainer Clip
5— Halogen Bulb
6— Connector

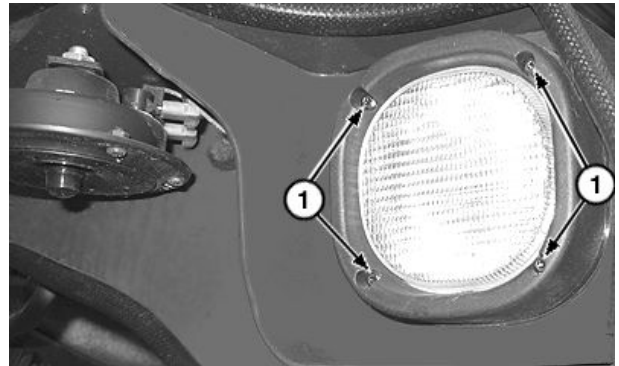

Four Screws for Light Assembly

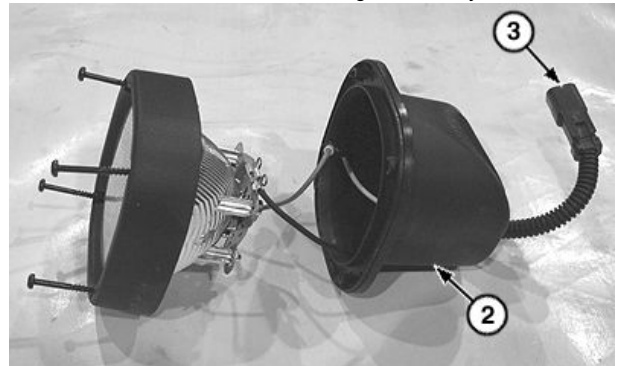

Bulb Housing and Wire Connector

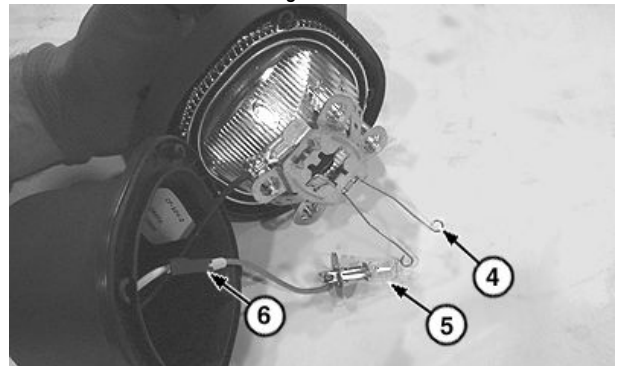

Retainer Clip and Halogen Bulb

TX1066041A —UN—13OCT09

TX1066042A —UN—13OCT09

TX1066043A —UN—13OCT09

OUT4001.00004EE -19-12NOV12-1/1

Adding Rear Counterweights

There are three optional sets of counterweights that can be added to machine.

Use a suitable lifting device to put each counterweight on machine.

Specification

Counterweight—Weight (each).....	39 kg 86 lb
-------------------------------------	----------------

1. Line up counterweight holes with three threaded holes on machine.

NOTE: For the top two cap screws, place spacers between the counterweight and machine frame.

2. Install spacers and tighten M16 x 70 mm flange cap screws (1).
3. Stack second counterweight on first counterweight and line up holes.
4. Install M16 x 120 mm flange cap screws (2) and tighten with nuts.
5. Stack third counterweight on second counterweight and line up holes.
6. Install M16 x 120 mm flange cap screws (3) and tighten with nuts.

- | | |
|--|--|
| 1— M16 x 70 mm Flange Cap
Screw (3 used) | 3— M16 x 120 mm Flange Cap
Screw (3 used) |
| 2— M16 x 120 mm Flange Cap
Screw (2 used) | |

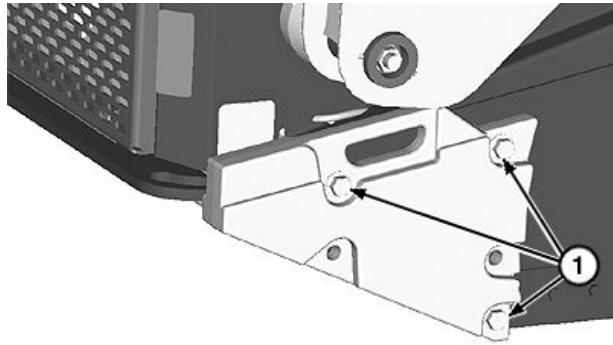

TX1066135A—UN—15OCT09

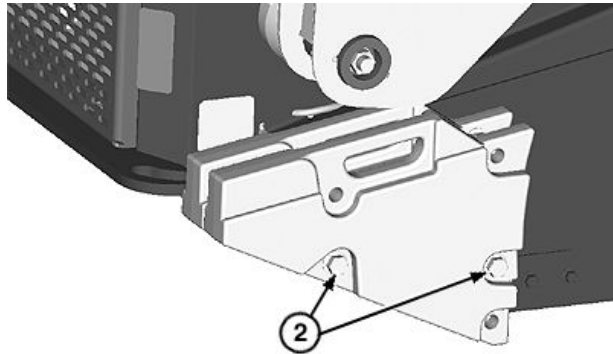

TX1066136A—UN—15OCT09

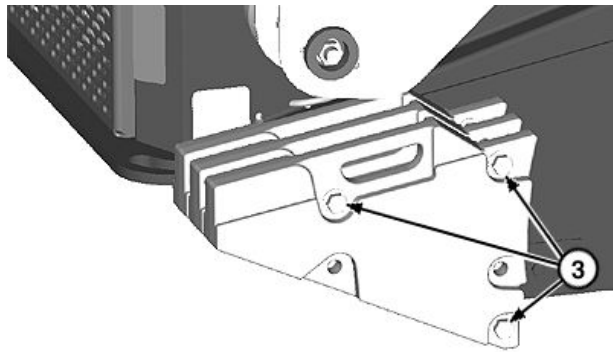

TX1066137A—UN—15OCT09

OUT4001,00004F0 -19-24NOV09-1/1

Replacing Alternator Belt

1. Inspect belt for cracks, fraying, or stretched out areas. Replace if necessary.
2. To replace belt, release tension on belt.
3. Remove belt from pulleys, and discard belt.
4. Install new belt, making sure belt is correctly seated in all pulley grooves.
5. Start engine, and check belt alignment.

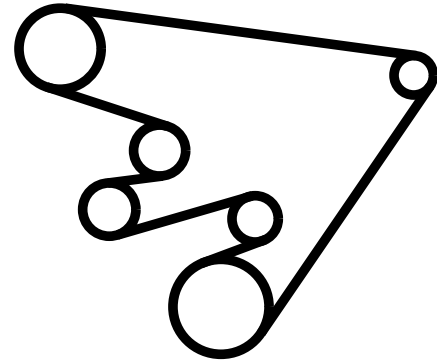

With Air Conditioner

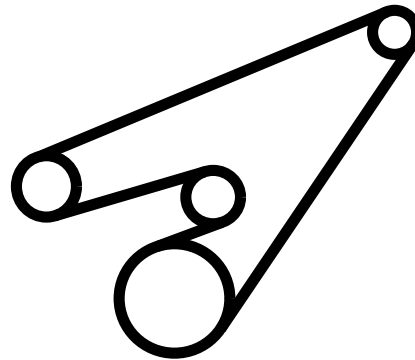

Without Air Conditioner

OUT4001,00004F1 -19-03NOV09-1/1

TX1066463 —UN—19OCT09

TX1066464 —UN—19OCT09

Adjusting Boom and Bucket Linkage—Hands Only Machines

If boom and bucket cycle times are slow, adjust boom and bucket linkage.

1. Raise boom and lock in raised position.
2. Park machine and shut OFF engine.
3. Turn key to RUN position.
4. Press park brake switch to middle position to actuate hydraulics while park brake is engaged.
5. Pivot each control lever left and right. Ensure that boom control valve locks into detent.
6. Confirm that when control levers are returned to neutral position, they are in the center of opening range.
7. Raise and lock operator's station in up position.
8. Remove footwell.
9. If necessary, adjust positions of cables forward or backward using nuts (1) to properly position control levers.

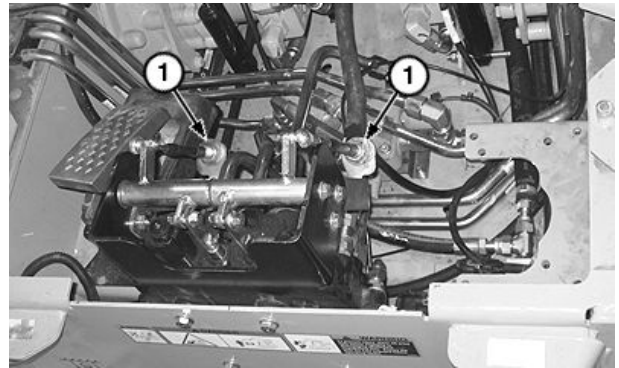

1— Nut (2 used)

10. Install footwell and lower operator's station.
11. Lower boom to the ground.

OUT4001,00004F2 -19-05NOV09-1/1

TX1066107A —UN—15OCT09

Adjusting Pedal Angle—Hand and Foot Machines

The angle of the pedals can be adjusted to suit different operators or different footwear.

Adjust the angle by increasing or decreasing the length of the rods (1).

Increasing length of the rod, increases pedal angle.
Decreasing length of the rod, decreases pedal angle.

1. Remove footwell.
2. Loosen nuts (2).
3. Turn the rod to desired length until pedal is at comfortable angle. Make sure there is still thread engagement.
4. Tighten nuts.
5. Install footwell.

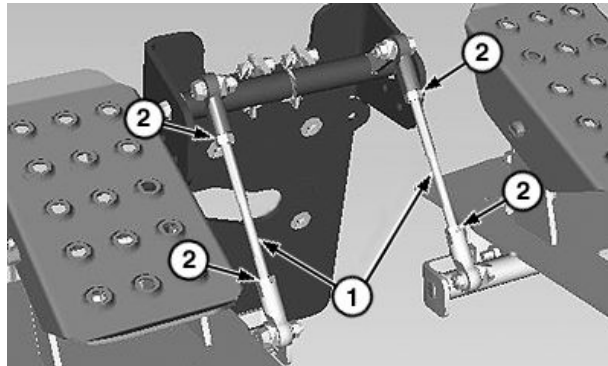

1—Rod (2 used)

2—Nut (4 used)

TX1066428A—UN—16OCT09

OUT4001,00004F3 -19-05NOV09-1/1

Replacing Fuses

1. Fuses are located in operator's station on the right side.
2. Remove fuse panel cover (1).
3. Pull off protective cap.
4. Pull fuse out of socket.
5. Check metal clip in fuse window. Discard fuse if clip is broken.
6. Push new fuse into proper socket. Be sure new fuse is the same amperage as removed fuse.

1—Fuse Panel Cover



Fuse Panel Cover

TX1066401A—UN—16OCT09

Continued on next page

OUT4001,00004F5 -19-03DEC12-1/2

- | | |
|---|---|
| F1— Key Switch Unswitched Power 7.5 A Fuse | F8— Air Conditioner and Heater 30 A Fuse |
| F2— Monitor Unswitched Power 10 A Fuse | F14— Quik-Tatch 30 A Fuse |
| F3— ECU Unswitched Power 20 A Fuse | F15— Switched Power 10 A Fuse |
| F4— Air Seat 10 A Fuse | F16— Horn 10 A Fuse (switch A) |
| F5— Dome Light and Accessory Power Socket 10 A Fuse | F17— Handle Switches 5 A Fuse (switch B, G, H) |
| F6— Lights 20 A Fuse | F18— Handle Switches 5 A Fuse (switch C, D, E, F) |
| F7— Accessory 15 A Fuse | |

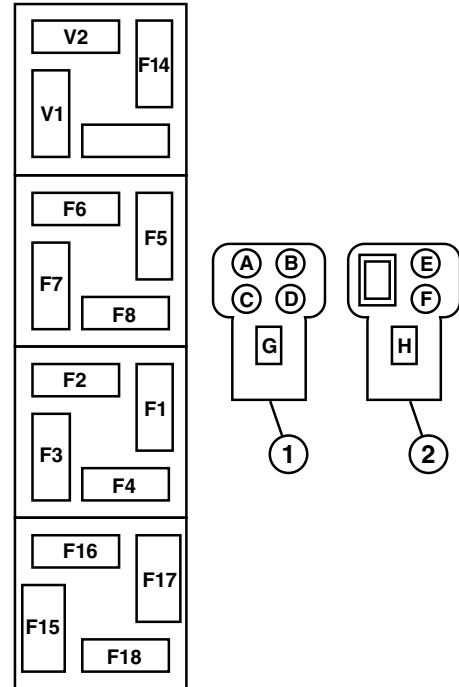

Fuse Designations

OUT4001,00004F5 -19-03DEC12-2/2

TX1127170—UN—04JAN13

Replacing Glow Plug Fuse

1. Park machine.
2. Raise and lock operator's station in up position.
3. Loosen cap screws and remove fuse and relay center cover (1).
4. Locate F9 glow plug 60 A fuse (2).
5. Pull fuse out of socket.
6. Check metal clip in fuse window. Discard fuse if clip is broken.
7. Push new fuse into socket. Be sure new fuse is the same amperage as removed fuse.
8. Install fuse and relay center cover.
9. Lower operator's station.

- | | |
|--------------------------------|---------------------------|
| 1— Fuse and Relay Center Cover | 2— F9 Glow Plug 60 A Fuse |
|--------------------------------|---------------------------|

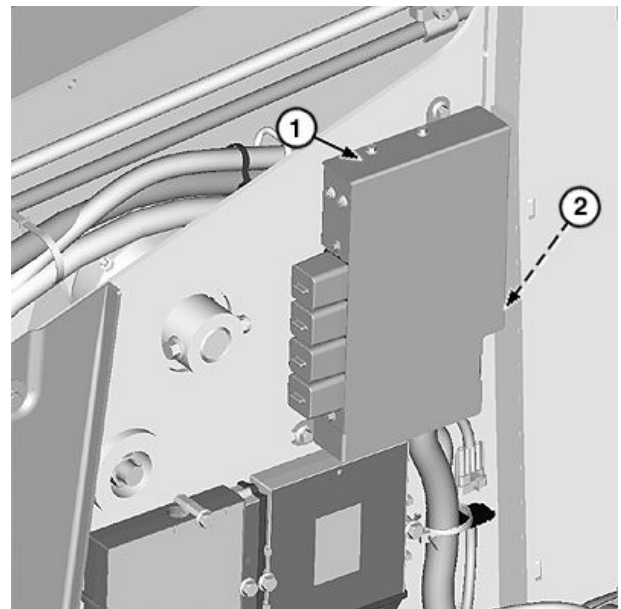

Glow Plug Fuse

OUT4001,00004F6 -19-12NOV12-1/1

TX1066436A—UN—16OCT09

Hardware Torque Specifications

Check cap screws and nuts to be sure they are tight. If hardware is loose, tighten to torque shown on the following charts unless a special torque is specified.

TX,90,FF1225 -19-16JAN08-1/1

Unified Inch Bolt and Screw Torque Values

TS1671 —UN—01MAY03

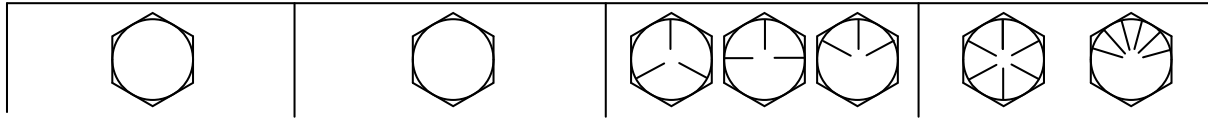

Bolt or Screw Size	SAE Grade 1				SAE Grade 2 ^a				SAE Grade 5, 5.1 or 5.2				SAE Grade 8 or 8.2			
	Lubricated ^b		Dry ^c		Lubricated ^b		Dry ^c		Lubricated ^b		Dry ^c		Lubricated ^b		Dry ^c	
	N-m	lb.-in.	N-m	lb.-in.	N-m	lb.-in.	N-m	lb.-in.	N-m	lb.-in.	N-m	lb.-in.	N-m	lb.-in.	N-m	lb.-in.
1/4	3.7	33	4.7	42	6	53	7.5	66	9.5	84	12	106	13.5	120	17	150
													N-m	lb.-ft.	N-m	lb.-ft.
5/16	7.7	68	9.8	86	12	106	15.5	137	19.5	172	25	221	28	20.5	35	26
									N-m	lb.-ft.	N-m	lb.-ft.				
3/8	13.5	120	17.5	155	22	194	27	240	35	26	44	32.5	49	36	63	46
			N-m	lb.-ft.	N-m	lb.-ft.	N-m	lb.-ft.								
7/16	22	194	28	20.5	35	26	44	32.5	56	41	70	52	80	59	100	74
	N-m	lb.-ft.														
1/2	34	25	42	31	53	39	67	49	85	63	110	80	120	88	155	115
9/16	48	35.5	60	45	76	56	95	70	125	92	155	115	175	130	220	165
5/8	67	49	85	63	105	77	135	100	170	125	215	160	240	175	305	225
3/4	120	88	150	110	190	140	240	175	300	220	380	280	425	315	540	400
7/8	190	140	240	175	190	140	240	175	490	360	615	455	690	510	870	640
1	285	210	360	265	285	210	360	265	730	540	920	680	1030	760	1300	960
1-1/8	400	300	510	375	400	300	510	375	910	670	1150	850	1450	1075	1850	1350
1-1/4	570	420	725	535	570	420	725	535	1280	945	1630	1200	2050	1500	2600	1920
1-3/8	750	550	950	700	750	550	950	700	1700	1250	2140	1580	2700	2000	3400	2500
1-1/2	990	730	1250	930	990	730	1250	930	2250	1650	2850	2100	3600	2650	4550	3350

Torque values listed are for general use only, based on the strength of the bolt or screw. DO NOT use these values if a different torque value or tightening procedure is given for a specific application. For plastic insert or crimped steel type lock nuts, for stainless steel fasteners, or for nuts on U-bolts, see the tightening instructions for the specific application. Shear bolts are designed to fail under predetermined loads. Always replace shear bolts with identical grade.

Replace fasteners with the same or higher grade. If higher grade fasteners are used, tighten these to the strength of the original. Make sure fastener threads are clean and that you properly start thread engagement. When possible, lubricate plain or zinc plated fasteners other than lock nuts, wheel bolts or wheel nuts, unless different instructions are given for the specific application.

^aGrade 2 applies for hex cap screws (not hex bolts) up to 6 in. (152 mm) long. Grade 1 applies for hex cap screws over 6 in. (152 mm) long, and for all other types of bolts and screws of any length.

^b"Lubricated" means coated with a lubricant such as engine oil, fasteners with phosphate and oil coatings, or 7/8 in. and larger fasteners with JDM F13C, F13F or F13J zinc flake coating.

^c"Dry" means plain or zinc plated without any lubrication, or 1/4 to 3/4 in. fasteners with JDM F13B, F13E or F13H zinc flake coating.

DX,TORQ1 -19-12JAN11-1/1

Metric Bolt and Screw Torque Values

TS1670 —UN—01MAY03

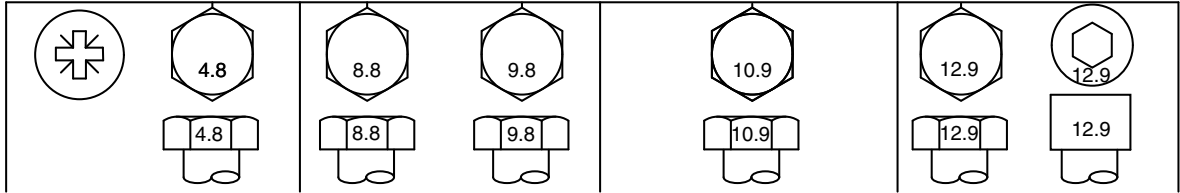

Bolt or Screw Size	Class 4.8				Class 8.8 or 9.8				Class 10.9				Class 12.9			
	Lubricated ^a		Dry ^b		Lubricated ^a		Dry ^b		Lubricated ^a		Dry ^b		Lubricated ^a		Dry ^b	
	N·m	lb.-in.	N·m	lb.-in.	N·m	lb.-in.	N·m	lb.-in.	N·m	lb.-in.	N·m	lb.-in.	N·m	lb.-in.	N·m	lb.-in.
M6	4.7	42	6	53	8.9	79	11.3	100	13	115	16.5	146	15.5	137	19.5	172
M8	11.5	102	14.5	128	22	194	27.5	243	32	23.5	40	29.5	37	27.5	47	35
M10	23	204	29	21	43	32	55	40	63	46	80	59	75	55	95	70
M12	40	29.5	50	37	75	55	95	70	110	80	140	105	130	95	165	120
M14	63	46	80	59	120	88	150	110	175	130	220	165	205	150	260	190
M16	100	74	125	92	190	140	240	175	275	200	350	255	320	235	400	300
M18	135	100	170	125	265	195	330	245	375	275	475	350	440	325	560	410
M20	190	140	245	180	375	275	475	350	530	390	675	500	625	460	790	580
M22	265	195	330	245	510	375	650	480	725	535	920	680	850	625	1080	800
M24	330	245	425	315	650	480	820	600	920	680	1150	850	1080	800	1350	1000
M27	490	360	625	460	950	700	1200	885	1350	1000	1700	1250	1580	1160	2000	1475
M30	660	490	850	625	1290	950	1630	1200	1850	1350	2300	1700	2140	1580	2700	2000
M33	900	665	1150	850	1750	1300	2200	1625	2500	1850	3150	2325	2900	2150	3700	2730
M36	1150	850	1450	1075	2250	1650	2850	2100	3200	2350	4050	3000	3750	2770	4750	3500

Torque values listed are for general use only, based on the strength of the bolt or screw. DO NOT use these values if a different torque value or tightening procedure is given for a specific application. For stainless steel fasteners or for nuts on U-bolts, see the tightening instructions for the specific application. Tighten plastic insert or crimped steel type lock nuts by turning the nut to the dry torque shown in the chart, unless different instructions are given for the specific application.

Shear bolts are designed to fail under predetermined loads. Always replace shear bolts with identical property class. Replace fasteners with the same or higher property class. If higher property class fasteners are used, tighten these to the strength of the original. Make sure fastener threads are clean and that you properly start thread engagement. When possible, lubricate plain or zinc plated fasteners other than lock nuts, wheel bolts or wheel nuts, unless different instructions are given for the specific application.

^a"Lubricated" means coated with a lubricant such as engine oil, fasteners with phosphate and oil coatings, or M20 and larger fasteners with JDM F13C, F13F or F13J zinc flake coating.

^b"Dry" means plain or zinc plated without any lubrication, or M6 to M18 fasteners with JDM F13B, F13E or F13H zinc flake coating.

Miscellaneous—Operational Checkout

Operational Checkout

Use this procedure to make a quick check of machine operation by doing a walk around inspection and performing specific checks from operator's seat.

Complete visual checks (oil levels, oil condition, external leaks, loose hardware, linkage, wiring, etc.) before performing operational checkout.

Most checks will require machine systems to be at normal operating temperatures and a level area with adequate

space to operate machine. Some checks may require varied surfaces.

No special tools are necessary to perform the checkout.

If no problem is found, go to next check. If problem is indicated, an additional check or repair procedure will be suggested.

OUT4001,000051D -19-17JUN11-1/27

Key Switch OFF, Engine OFF Checks

OUT4001,000051D -19-17JUN11-2/27

1 Diagnostic Trouble Code Check

Always check for diagnostic trouble codes and correct them before performing the operational checkout.

Diagnostic trouble codes are displayed on the engagement and monitor unit (EMU). Sit in seat and access diagnostic trouble code menu.

LOOK: Are diagnostic trouble codes present?

YES: See your authorized dealer.

NO: Proceed with operational checkout.

OUT4001,000051D -19-17JUN11-3/27

2 Engagement and Monitor Unit (EMU) Circuits Check

Sit in operator's seat.

LOOK: Do all indicators illuminate and then go out depending on machine status?

LOOK: Do all EMU display segments turn on, turn off, display TMC BY DEERE for 2 seconds, display correct machine model and speed setting for 2 seconds, and then display the hour meter?

Lower interlocking seat bar.

LOOK: Do seat and interlocking seat bar indicators go off?

YES: Go to next check.

NO: Check monitor unswitched power 10 amp fuse (F2).

NO: See your authorized dealer.

OUT4001,000051D -19-17JUN11-4/27

Key Switch ON, Engine OFF Checks

Continued on next page

OUT4001,000051D -19-17JUN11-5/27

Miscellaneous—Operational Checkout

<p>1 EMU Circuits Check</p>	<p>Turn key switch ON.</p> <p><i>LOOK: Do gauges move to the far right position, then move to the center position, and then display the machine status?</i></p> <p><i>LOOK: Do switches on control panel illuminate?</i></p> <p><i>LISTEN: Does EMU alarm sound?</i></p> <p>Close cab door—if equipped.</p> <p><i>LOOK: Does the cab door indicator go off?</i></p>	<p>YES: Go to next check.</p> <p>NO: Check key switch unswitched power 7.5 amp fuse (F1).</p> <p>NO: Check monitor unswitched power 10 amp fuse (F2).</p> <p>NO: Check switched power 10 amp fuse (F15).</p> <p>NO: See your authorized dealer.</p>
<p>OUT4001,000051D -19-17JUN11-6/27</p>		

<p>2 Horn Circuit Check (If Equipped)</p>	<p>Press the horn switch.</p> <p><i>LISTEN: Does horn sound?</i></p>	<p>YES: Go to next check.</p> <p>NO: Check key switch unswitched power 7.5 amp fuse (F1).</p> <p>NO: Check horn 10 amp fuse (F16).</p> <p>NO: See your authorized dealer.</p>
<p>OUT4001,000051D -19-17JUN11-7/27</p>		

<p>3 Lights Circuit Check</p>	<p>Push light switch to middle position.</p> <p><i>LOOK: Do front work lights and tail lights turn on?</i></p>	<p>YES: Go to next step in this check.</p> <p>NO: Check lights 20 amp fuse (F6).</p> <p>NO: Check key switch unswitched power 7.5 amp fuse (F1).</p> <p>NO: See your authorized dealer.</p>
	<p>Push light switch to upper position.</p> <p><i>LOOK: Do front work lights and tail lights stay on and rear work light turn on?</i></p>	<p>YES: Go to next step in this check.</p> <p>NO: See your authorized dealer.</p>
	<p>If equipped, push dual flasher switch to the upper position.</p> <p><i>LOOK: Do the dual flashers turn on?</i></p>	<p>YES: Go to next check.</p> <p>NO: See your authorized dealer.</p>
<p>Continued on next page OUT4001,000051D -19-17JUN11-8/27</p>		

Miscellaneous—Operational Checkout

<p>4 Windshield Wiper Circuit Check (If Equipped)</p>	<p>Close cab door.</p> <p>Push windshield wiper and washer switch to the middle position.</p> <p><i>LOOK: Does wiper operate?</i></p>	<p>YES: Go to next check.</p> <p>NO: Check accessory 20 amp fuse (F7).</p> <p>NO: Check key switch unswitched power 7.5 amp fuse (F1).</p> <p>NO: See your authorized dealer.</p> <p>OUT4001,000051D -19-17JUN11-9/27</p>
--	---	---

<p>5 Windshield Washer Circuit Check (If Equipped)</p>	<p>Close cab door.</p> <p>Turn on windshield wiper.</p> <p>Push and hold windshield wiper and washer switch in the upper position.</p> <p>IMPORTANT: Avoid damage to washer motor. Washer motor may be damaged if washer switch is held for more than 20 seconds, or continually operated with no fluid in the washer fluid tank.</p> <p><i>LOOK: Does washer operate?</i></p>	<p>YES: Go to next check.</p> <p>NO: Check washer fluid level.</p> <p>NO: Check washer hose for kinks or obstructions.</p> <p>NO: Check accessory 20 amp fuse (F7).</p> <p>NO: Check key switch unswitched power 7.5 amp fuse (F1).</p> <p>NO: See your authorized dealer.</p> <p>OUT4001,000051D -19-17JUN11-10/27</p>
---	---	---

Key Switch ON, Engine ON Checks

OUT4001,000051D -19-17JUN11-11/27

<p>1 Engine Start Check</p>	<p>Position engine speed control dial in slow idle position.</p> <p>Start engine.</p> <p><i>LISTEN/LOOK: Does engine speed increase briefly, then return to slow idle?</i></p>	<p>YES: Go to next check.</p> <p>NO: Check slow idle and fast idle engine speeds.</p> <p>OUT4001,000051D -19-17JUN11-12/27</p>
------------------------------------	--	--

<p>2 Engine Idle Check</p>	<p>Position engine speed control dial in slow idle position.</p> <p><i>LISTEN: Does engine idle poorly?</i></p>	<p>YES: Check water separator fuel filter. See Check and Drain Water Separator Fuel Filter. (Section 3-4.)</p> <p>YES: Test diesel fuel. See Testing Diesel Fuel. (Section 3-1.)</p> <p>YES: See your authorized dealer.</p> <p>NO: Go to next check.</p> <p>OUT4001,000051D -19-17JUN11-13/27</p>
-----------------------------------	---	--

Continued on next page

Miscellaneous—Operational Checkout

<p>3 Engine Speed Check</p>	<p>Set EMU to display engine rpm.</p> <p>Set engine speed at slow idle with engine speed control dial and engine speed control pedal released.</p> <p><i>LOOK/LISTEN: Does engine run between 1150—1250 rpm?</i></p> <p>Rotate engine speed control dial to set the engine speed at fast idle. Engine speed control pedal must be released.</p> <p><i>LOOK/LISTEN: Does engine run between 2750—2850 rpm (S.N. —202965) 2950—3050 rpm (S.N. 202966—)?</i></p> <p>Fully depress engine speed control pedal to set engine speed at fast idle. Engine speed control dial must be in slow idle position.</p> <p><i>LOOK/LISTEN: Does engine run between 2750—2850 rpm (S.N. —202965) 2950—3050 rpm (S.N. 202966—)?</i></p>	<p>YES: Go to next check.</p> <p>NO: Check diagnostic trouble codes (DTCs).</p> <p>NO: See your authorized dealer.</p>
------------------------------------	--	---

OUT4001,000051D -19-17JUN11-14/27

<p>4 Hydraulic Control Enable Check</p>	<p>Close cab door—if equipped.</p> <p>Engine speed at slow idle.</p> <p>Engage park brake.</p> <p>Actuate boom and bucket functions.</p> <p><i>LOOK: Does boom and bucket move?</i></p>	<p>NO: Go to next step in this check.</p> <p>YES: See your authorized dealer.</p>
	<p>Move park brake switch to the run position to enable hydraulics.</p> <p>Actuate boom and bucket functions.</p> <p><i>LOOK: Does boom and bucket move?</i></p>	<p>YES: Go to next check.</p> <p>NO: See your authorized dealer.</p>

OUT4001,000051D -19-17JUN11-15/27

<p>5 Electric Quik-Tatch™ Check (If Equipped)</p>	<p>IMPORTANT: Avoid damage to Quik-Tatch™ motor. Damage to Quik-Tatch motor will occur if motor is immersed in liquid. Do not immerse in liquid.</p> <p>Close cab door—if equipped.</p> <p>Press and hold lower part of Quik-Tatch switch to unlock the Quik-Tatch latches.</p> <p><i>LOOK/LISTEN: Do Quik-Tatch latches release attachment?</i></p> <p>Press and hold upper part of Quik-Tatch switch to lock the Quik-Tatch latches.</p> <p><i>LOOK/LISTEN: Do Quik-Tatch latches secure attachment?</i></p>	<p>YES: Go to next check.</p> <p>NO: See your authorized dealer.</p>
--	---	--

Quik-Tatch is a trademark of Deere & Company

Continued on next page

OUT4001,000051D -19-17JUN11-16/27

Miscellaneous—Operational Checkout

<p>6 Back-Up Alarm Check (If Equipped)</p>	<p>CAUTION: Prevent injury from unexpected machine movement. Keep bystanders clear of machine.</p> <p>Engine speed at slow idle. Drive machine in reverse.</p> <p><i>LOOK/LISTEN: Does back-up alarm sound?</i></p>	<p>YES: Go to next check. NO: Check accessory 20 amp fuse (F7) and key switch unswitched power 7.5 amp fuse (F1). NO: See your authorized dealer.</p>
OUT4001,000051D -19-17JUN11-17/27		

<p>7 Steering Mistracking Check</p>	<p>CAUTION: Prevent injury from unexpected machine movement. Keep bystanders clear of machine.</p> <p>Engine speed at fast idle. Drive machine at full speed forward on a flat and level surface for 30 m (100 ft.). Repeat procedure for reverse direction. Observe which direction and how much the machine mistracks from a straight line.</p> <p><i>LOOK: Does machine mistrack more than the width of the machine over 30 m (100 ft.)?</i></p>	<p>YES: See your authorized dealer. NO: Go to next check.</p>
OUT4001,000051D -19-17JUN11-18/27		

<p>8 Boom Down Drift Check</p>	<p><i>NOTE: This check may require two people.</i></p> <p><i>NOTE: Machine must be equipped with a bucket for this check.</i></p> <p>Close cab door—if equipped. Operate hydraulic system until hydraulic oil reaches temperature specification.</p> <p style="text-align: center;">Specification</p> <p>Hydraulic Oil—Temperature..... 43°C 110°F</p> <p>Actuate boom function to lower boom to ground. Raise boom halfway. Engage park brake. Mark and record a distance on the boom cylinder rod from the cylinder barrel. Disengage park brake. Allow machine to sit with engine speed at slow idle for 5 minutes. Engage park brake. Measure marked distance on boom cylinder rod.</p> <p style="text-align: center;">Specification</p> <p>Boom Cylinder—Drift (maximum)..... 12.7 mm/5 min. 0.5 in./5 min.</p> <p><i>LOOK: Does boom drift down more than specification?</i></p>	<p>NO: Go to next step in this check. YES: Go to next check.</p>
<p></p>	<p>Raise boom halfway. Engage park brake. Turn engine off. Allow machine to sit for 5 minutes.</p> <p style="text-align: center;">Specification</p> <p>Boom Cylinder—Drift (maximum)..... 12.7 mm/5 min. 0.5 in./5 min.</p> <p><i>LOOK: Does boom drift down more than specification?</i></p>	<p>YES: See your authorized dealer. NO: Go to next check.</p>
Continued on next page		
OUT4001,000051D -19-17JUN11-19/27		

Miscellaneous—Operational Checkout

<p>9 Boom Up Drift Check</p>	<p><i>NOTE: This check may require two people.</i></p> <p><i>NOTE: Machine must be equipped with a bucket for this check.</i></p> <p>Close cab door—if equipped.</p> <p>Operate hydraulic system until hydraulic oil reaches temperature specification.</p> <p style="text-align: center;">Specification</p> <p>Hydraulic Oil—Temperature..... 43°C 110°F</p> <p><i>NOTE: Bucket may need to be in dump position.</i></p> <p>Actuate boom down function to raise front of machine off the ground.</p> <p>Engage park brake.</p> <p>Mark and record a distance on the boom cylinder rod from the cylinder barrel.</p> <p>Disengage park brake.</p> <p>Allow machine to sit with engine speed at slow idle for 5 minutes.</p> <p>Engage park brake.</p> <p>Measure marked distance on boom cylinder rod.</p> <p style="text-align: center;">Specification</p> <p>Boom Circuit—Drift (maximum)..... 12.7 mm/5 min. 0.5 in./5 min.</p> <p><i>LOOK: Does boom drift up more than specification?</i></p>	<p>NO: Go to next step in this check.</p> <p>YES: Go to next check.</p>
	<p>Actuate boom down function to raise front of machine off the ground.</p> <p>Engage park brake.</p> <p>Turn engine off.</p> <p>Allow machine to sit for 5 minutes.</p> <p style="text-align: center;">Specification</p> <p>Boom Cylinder—Drift (maximum)..... 12.7 mm/5 min. 0.5 in./5 min.</p> <p><i>LOOK: Does boom drift up more than specification?</i></p>	<p>YES: See your authorized dealer.</p> <p>NO: Go to next check.</p>

Continued on next page

OUT4001,000051D -19-17JUN11-20/27

Miscellaneous—Operational Checkout

10 Bucket Dump Drift Check

NOTE: This check may require two people.

NOTE: Machine must be equipped with a bucket for this check.

Close cab door—if equipped.

Operate hydraulic system until hydraulic oil reaches temperature specification.

Specification

Hydraulic Oil—Temperature..... 43°C
110°F

Raise boom halfway.

Fully roll back bucket.

Dump bucket halfway.

Engage park brake.

Mark and record a distance on the bucket cylinder rod from the cylinder barrel.

Disengage park brake.

Allow machine to sit with engine speed at slow idle for 5 minutes.

Engage park brake.

Measure marked distance on bucket cylinder rod.

Specification

Bucket Circuit—Drift (maximum)..... 12.7 mm/5 min.
0.5 in./5 min.

LOOK: Does bucket drift down more than specification?

NO: Go to next step in this check.

YES: Go to next check.

Raise boom halfway.

Fully roll back bucket.

Dump bucket halfway.

Engage park brake.

Turn engine off.

Allow machine to sit for 5 minutes.

Specification

Bucket Cylinder—Drift (maximum)..... 12.7 mm/5 min.
0.5 in./5 min.

LOOK: Does bucket drift down more than specification?

YES: See your authorized dealer.

NO: Go to next check.

Continued on next page

OUT4001,000051D -19-17JUN11-21/27

Miscellaneous—Operational Checkout

<p>11 Bucket Curl Drift Check</p>	<p><i>NOTE: This check may require two people.</i></p> <p><i>NOTE: Machine must be equipped with a bucket for this check.</i></p> <p>Close cab door—if equipped. Operate hydraulic system until hydraulic oil reaches temperature specification.</p> <p style="text-align: center;">Specification</p> <p>Hydraulic Oil—Temperature..... 43°C 110°F</p> <p>Dump bucket halfway. Actuate boom down function to raise front of machine off the ground. Engage park brake. Mark and record a distance on the bucket cylinder rod from the cylinder barrel. Disengage park brake. Allow machine to sit with engine speed at slow idle for 5 minutes. Engage park brake. Measure marked distance on bucket cylinder rod.</p> <p style="text-align: center;">Specification</p> <p>Bucket Circuit—Drift (maximum)..... 12.7 mm/5 min. 0.5 in./5 min.</p> <p><i>LOOK: Does bucket drift up more than specification?</i></p>	<p>NO: Go to next step in this check.</p> <p>YES: Go to next check.</p>
	<p>Dump bucket halfway. Actuate boom down function to raise front of machine off the ground. Engage park brake. Turn engine off. Allow machine to sit for 5 minutes.</p> <p style="text-align: center;">Specification</p> <p>Bucket Cylinder—Drift (maximum)..... 12.7 mm/5 min. 0.5 in./5 min.</p> <p><i>LOOK: Does bucket drift up more than specification?</i></p>	<p>YES: See your authorized dealer.</p> <p>NO: Go to next check.</p>

OUT4001,000051D -19-17JUN11-22/27

<p>12 Auxiliary Hydraulic Override Check</p>	<p>⚠ CAUTION: Prevent injury from operating attachments. Stay clear of moving parts on the attachment.</p> <p>Close cab door—if equipped. Operate auxiliary hydraulic function. Raise interlocking seat bar and exit machine. <i>LISTEN/LOOK: Do the auxiliary hydraulics shut off?</i> Return to seat, lower interlocking seat bar and close cab door—if equipped. Operate auxiliary hydraulic function. Press auxiliary hydraulic override switch. <i>LOOK: Does "AUX HYDRAULIC BYPASS" appear in EMU display?</i> <i>NOTE: Operator must exit machine within 15 seconds of pressing auxiliary hydraulic override switch.</i> Open cab door and exit machine. <i>LISTEN/LOOK: Do the auxiliary hydraulics continue to operate after operator has exited the machine?</i> Return to seat, lower interlocking seat bar and close cab door, if equipped. Disengage auxiliary hydraulics. <i>LOOK: Does EMU exit "AUX HYDRAULIC BYPASS" mode and return to last run data item?</i></p>	<p>YES: Go to next check.</p> <p>NO: See your authorized dealer.</p>
---	---	--

Continued on next page

OUT4001,000051D -19-17JUN11-23/27

Miscellaneous—Operational Checkout

13 Self Leveling Valve Check (If Equipped)

NOTE: Self leveling function is only active for boom up function.

Close cab door—if equipped.
 Lower boom to the ground.
 Position bottom of bucket on the ground.
 Raise boom.
LOOK: Does bucket self level as boom is raised?

YES: Go to next check.
NO: See your authorized dealer.

OUT4001,000051D -19-17JUN11-24/27

14 Heating and Air Conditioning System Check

NOTE: Engine will need to be at operating temperature for this check.

Engine speed at slow idle.
 Turn blower speed dial from off to slow, medium and high speeds.
LISTEN/FEEL: Does fan speed increase and/or decrease as switch is moved?
 Turn blower speed dial to a medium speed setting.
 Turn cab temperature control dial to hot (red).
FEEL: Does warm air come out of air ducts?
 Turn cab temperature control dial to cold (blue).
FEEL: Does cool air come out of air ducts?
 Turn air conditioner switch on.

FEEL/LISTEN: Does cold air come out of air ducts after a couple of minutes?

YES: Go to next check.
NO: Check air conditioner and heater 15 amp fuse (F8).
NO: See your authorized dealer.

OUT4001,000051D -19-17JUN11-25/27

15 Cycle Times Check—319D

Operate hydraulic system until hydraulic oil reaches temperature specification.

Specification

Hydraulic Oil—Temperature..... 43°C
 110°F

Engine speed at fast idle.
 Record cycle time for each function.
 Does machine perform within specification?

Cycle Times—Specification

Boom Raise—Cycle Time (maximum).....4.2 sec
 Boom Lower—Cycle Time (maximum).....3.5 sec
 Bucket Curl—Cycle Time (maximum).....1.9 sec
 Bucket Dump—Cycle Time (maximum).....2.6 sec

YES: Check complete.
NO: See your authorized dealer.

Continued on next page

OUT4001,000051D -19-17JUN11-26/27

Miscellaneous—Operational Checkout

16 Cycle Times
Check—323D

Operate hydraulic system until hydraulic oil reaches temperature specification.

Specification

Hydraulic Oil—Temperature..... 43°C
110°F

Engine speed at fast idle.

Record cycle time for each function.

Does machine perform within specification?

Cycle Times—Specification

Boom Raise—Cycle Time (maximum).....3.2 sec
Boom Lower—Cycle Time (maximum).....3.4 sec
Bucket Curl—Cycle Time (maximum).....1.4 sec
Bucket Dump—Cycle Time (maximum).....1.9 sec

YES: Check complete.
NO: See your authorized dealer.

OUT4001,000051D -19-17JUN11-27/27

Miscellaneous—Troubleshooting

Troubleshooting Procedure

NOTE: Troubleshooting charts are arranged from the simplest to verify, to least likely, more difficult to verify. When diagnosing a problem, use all possible means to isolate the problem to a single component or system. Use the following steps to diagnose problems:

Step 1. Operational Checkout Procedure

Step 2. Troubleshooting Charts

Step 3. Adjustments

Step 4. See your authorized dealer

TX14740,00000CB -19-06FEB08-1/1

Engine

Symptom	Problem	Solution
Machine Will Not start	Park brake switch not engaged	Push upper half of switch.
	No power to key switch or park brake switch	Check fuse and battery connection.
	No power to starter	Check key switch, start relay, battery connection, and starter connection.
	Fuel tank empty	Add fuel.
	Improper fuel	Drain fuel tank and add proper fuel.
	Clogged fuel filter	Replace fuel filter.
	Air leak on suction side of fuel system	Check for bubbles in fuel filter and tighten connections. Inspect fuel lines for damage.
	Slow cranking speed	Check battery and connections.
	Restricted air filter	Check air filter restriction indicator and air filter.
Engine Surges, Stalls, Or Misses	Fuel tank vent clogged	Remove cap, and listen for sound of air entering tank. Replace cap.
	Improper fuel	Drain fuel tank, and add proper fuel.
	Restricted air filter	Check air filter restriction indicator and air filter.
	Fuel filter clogged	Replace filter.
Engine Overheats	Air intake screens clogged	Clean air intake screens.
	Incorrect coolant mixture	Check coolant mixture.
	Engine oil level low	Check engine oil dipstick.
	Loose or defective alternator belt	Check alternator belt.

OUT4001,000053B -19-03NOV09-1/1

Electrical System

Symptom	Problem	Solution
Park Brake Will Not Disengage	Interlocking seat bar switch is not activated	Lower interlocking seat bar to activate seat switch. Raise/lower interlocking seat bar to reactivate seat switch.
	Joysticks not in neutral (EH machines)	Move joysticks to neutral position.
	Park brake has not gone through the momentary down position (unlocked).	Push lower half of switch.
Park Brake Will Not Engage	Park brake is not in the up (locked) position	Push upper half of switch.
Starting Motor Will Not Turn	Battery terminals corroded	Check and clean as necessary.
	Loose connection at starter or starter relay	Check all electrical connections.
	Blown fuse	Replace fuse.
	Battery dead or low charge	Check battery voltage, and charge as necessary.
Engine Cranks Slowly	Low battery input	Check battery voltage, and charge as necessary.
	Loose or corroded battery cables	Inspect and clean or tighten.
	Engine oil viscosity too heavy	Verify engine oil viscosity.
Battery Will Not Charge	Dead cell in battery	Replace battery.
	Low engine speed or excessive idling	Increase engine rpm to raise alternator output.
	Battery cables and terminals dirty	Clean cables and connections as necessary.
	Alternator belt loose or damaged	Check belt. Tighten if loose.
Lights Do Not Work	Blown fuse	Replace fuse.
	Loose or bad bulb	Check bulb connection, or replace as necessary.
Battery Voltage Indicator Light Remains On With Engine Running	Loose or glazed alternator belt	Check belt. Tighten if loose. Replace if glazed.
	Low battery input	Check battery voltage, and charge as necessary.

OUT4001,0000501 -19-03NOV09-1/1

Hydraulic System

Symptom	Problem	Solution
Boom And Bucket Will Not Move	Joysticks not in neutral (EH machines)	Move joysticks to neutral position.
	Park brake will not engage	Interlocking seat bar switch not activated or not properly sequenced.
	Park brake engaged	Disengage park brake.
Excessive Pump Noise	Low oil level	Add oil to correct level.
	Suction line clogged	Check for line restriction, or replace hose as necessary.
	Air leaks at pump inlet line fittings	Check all hydraulic connections, and tighten as necessary.
Low Hydraulic Power	Hydraulic oil aerated	Drain hydraulic oil tank and refill.
	Low oil level	Check oil levels.
	Air leaks at pump inlet line fittings	Check all hydraulic connections, and tighten as necessary.
Slow Hydraulic Function	Auxiliary hydraulic roller locked in detent position	Return roller to neutral position.
	Boom or bucket overloaded	Lighten load on hydraulic function.
	Low oil level	Add oil to correct level.
	Engine rpm too low	Increase rpm, or check engine speed.
	Hydraulic oil aerated	Incorrect oil; drain and refill. Suction hose has air leak; inspect and tighten.
	Hose or line leakage	Inspect and tighten fittings.
Machine Loses Power	Dirty or clogged fuel water separator filter	Check fuel water separator filter.

OUT4001,0000502 -19-19OCT09-1/1

Miscellaneous—Machine Storage

Prepare Machine for Storage

IMPORTANT: Avoid machine damage, do not use biodiesel during machine storage. When using biodiesel blends, switch to petroleum diesel for long term storage.

1. Before storage, operate engine on at least one complete tank of petroleum diesel fuel to purge the fuel system. Ensure that the fuel tank is full during storage to prevent water buildup due to condensation.

NOTE: For blends up to and including B20, it is recommended that biodiesel be used within three months of its manufacture. For blends greater than B20, it is recommended that the biodiesel be used within 45 days. The poor oxidation stability characteristic of biodiesel can result in long-term storage problems. John Deere does not recommend using biodiesel in engines powering standby applications or vehicles operating on a seasonal basis. Consult your John Deere dealer or fuel supplier for additives to improve fuel storage and performance of biodiesel fuels. These additives must be added to the biodiesel close to its time of production for them to be effective.

2. Repair worn or damaged parts. Install new parts, if necessary, to avoid needless delays later.
3. Replace air cleaner elements.

IMPORTANT: High pressure washing greater than 1379 kPa (13.8 bar) (200 psi) can damage freshly painted finishes. Paint should be allowed to air dry for 30 days minimum after receipt of machine before cleaning parts or machines with high pressure. Use low pressure wash operations until 30 days have elapsed.

4. Wash the machine. Use low pressure wash operations (less than 1379 kPa (13.8 bar) (200 psi) until 30 days after receipt of machine have elapsed. Paint areas to prevent rust. Replace decals, where needed.

LPS is a trademark of the Holt Lloyd Corporation.

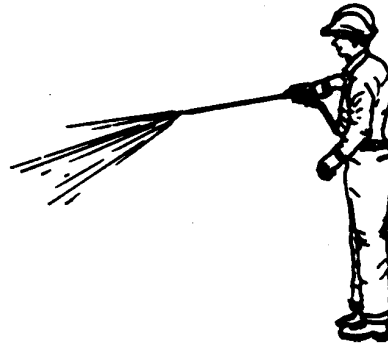

5. Apply waste oil to track chains. Run machine back and forth several times. Park machine on a hard surface to prevent tracks from freezing to ground.

6. Store machine in a dry, protected place. If stored outside, cover with a waterproof material.

IMPORTANT: LPS 3 Rust Inhibitor can destroy painted finish. DO NOT spray LPS 3 Rust Inhibitor on painted areas.

7. Retract all hydraulic cylinders, if possible. If not, coat exposed cylinder rods with LPS @ 3 Rust Inhibitor.
8. Place a DO NOT OPERATE tag on the right control lever.
9. Lubricate all grease points.
10. Remove the battery and store in a dry, protected place after charging fully. If not removed, disconnect the negative battery cable from the (—) terminal.
11. Drain water separator fuel filter.
12. Remove keys and lock engine cover and door, if equipped.

T5813AM—UN—09FEB89

OUT4001,00004EA -19-21OCT09-1/1

Monthly Storage Procedure

CAUTION: Prevent possible injury or death from asphyxiation. Engine exhaust fumes can cause sickness or death. Start engine **ONLY** in a well-ventilated area.

1. Drain water and sediment from fuel tank when air temperature is above freezing.
2. Remove LPS 3® Rust Inhibitor from cylinder rods with a cleaning solvent.

LPS 3 Rust Inhibitor is a trademark of Illinois Tool Works.

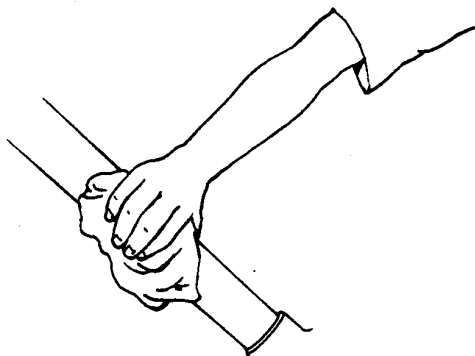

T6191AA—UN—18OCT88

VD76477,00016A3 -19-13JUN11-1/2

IMPORTANT: Prevent possible engine damage. During cold temperatures, check fluidity of engine oil on dipstick. If the oil appears waxy and/or jelly-like rather than liquid, **DO NOT** attempt to start engine. Use external heat source to warm the crankcase until oil appears fluid.

3. Check all fluid levels. If low, check for leaks and add oil as required.
4. Check belts.
5. Check condition of all hoses and connections.
6. Check battery electrolyte level. Charge and install battery.
7. For machines with **tires**, check condition of tires and tire pressure.

For machines with **tracks**, check condition of tracks and track sag.

On crawler machines with non sealed-and-lubricated track chains, apply oil to the pin-to-bushing joints. Run machine back and forth several times.

8. Park machine on a hard surface to prevent tracks from freezing to ground.
9. Fill fuel tank.
10. Pre-lubricate turbocharger bearings, if equipped:
 - a. Disconnect fuel shutoff fuse.
 - b. Crank engine for 10 seconds.
 - c. Connect fuel shutoff fuse.
11. Inspect engine compartment, and remove any foreign material that may have accumulated. Start engine and



T6181AU—UN—18OCT88

run until it reaches operating temperature. Run at 1/2 speed for five minutes. Do not run at fast or slow idle.

- If engine fails to start or runs poorly after starting, change fuel filter(s). Bleed fuel system.

12. Operate all controls, levers, seat adjustments, etc.

CAUTION: Prevent possible injury from unexpected machine movement. Clear the area of all persons before running machine through the operation procedure.

13. Make sure the area is clear to allow for movement. Cycle all hydraulic functions several times. Check condition of all hoses and connections.
14. Park the machine with cylinder rods retracted, if possible. Turn key switch to OFF.
15. Apply LPS 3 Rust Inhibitor to exposed cylinder rod areas.

VD76477,00016A3 -19-13JUN11-2/2

Miscellaneous—Machine Numbers

Record Product Identification Number (PIN)

Purchase Date _____

NOTE: Record all 13 characters of the PIN.

The PIN tag (1) is located on the right side of machine, above the boom lock.

1— PIN Tag

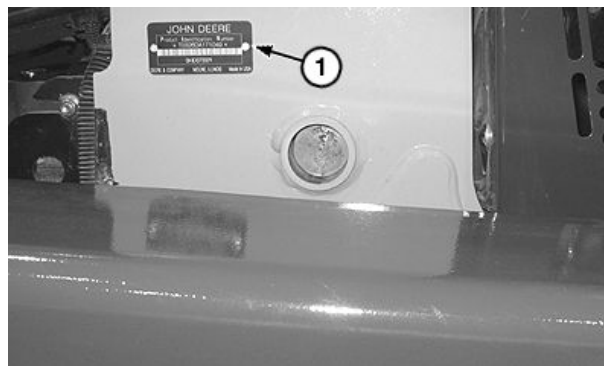

TX1066440A —UN—16OCT09

OUT4001,00004FB -19-16OCT09-1/1

Record Engine Serial Number

Engine Serial Number _____

The engine serial number tag (1) is located on the right side of the engine.

1— Engine Serial Number Tag

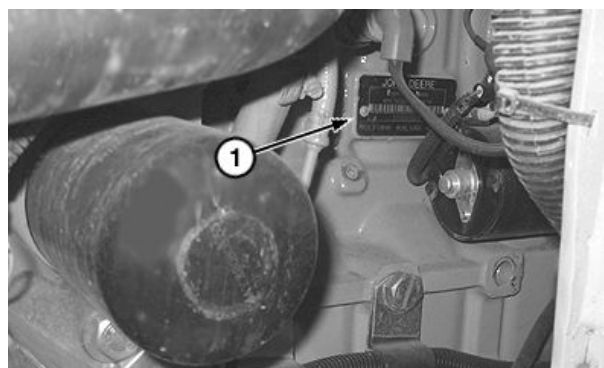

TX1066441A —UN—16OCT09

OUT4001,00004FC -19-16OCT09-1/1

Keep Proof of Ownership

1. Maintain in a secure location an up-to-date inventory of all product and component serial numbers.
2. Regularly verify that identification plates have not been removed. Report any evidence of tampering to law enforcement agencies and order duplicate plates.



TX1066156 —UN—15OCT09

OUT4001,00004F9 -19-16OCT09-1/1

Keep Machines Secure

1. Install vandal-proof devices.
2. When machine is in storage:
 - Lower equipment to the ground
 - Remove any keys and batteries
3. When parking indoors, put large equipment in front of exits and lock your storage buildings.
4. When parking outdoors, store in a well-lighted and fenced area.
5. Make note of suspicious activity and report any thefts immediately to law enforcement agencies.
6. Notify your John Deere dealer of any losses.

OUT4001,00004FA -19-16OCT09-1/1

Miscellaneous—Specifications

319D Machine Dimensions

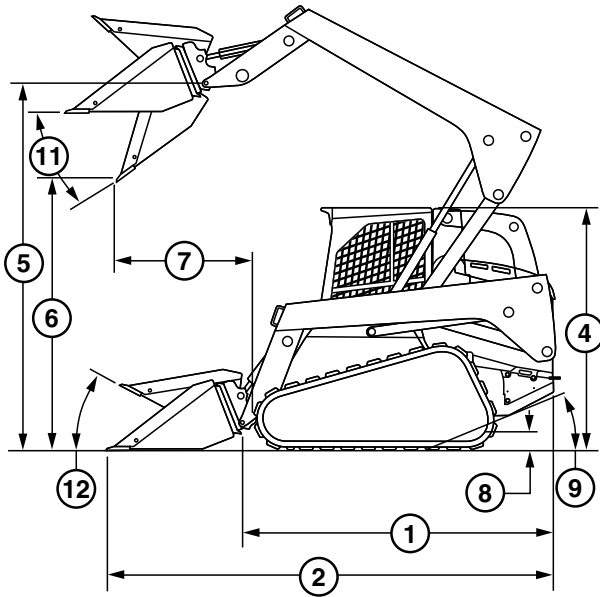

TX1065134—UN—28OCT09

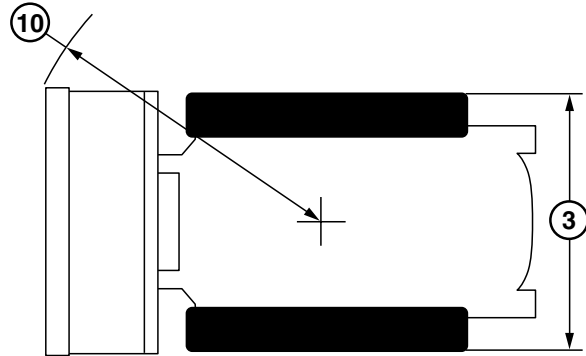

TX1065135—UN—28OCT09

NOTE: Specifications and design subject to change without notice. Wherever applicable, specifications are in accordance with ISO and SAE standards.

Except where otherwise noted, these specifications are based on a machine equipped with standard tracks and bucket.

Item	Measurement	Specification
1—Overall Length (less bucket)	Length	2.74 m 9 ft. 0 in.
2—Overall Length (with foundry bucket)	Length	3.36 m 11 ft. 0 in.
2—Overall Length (with construction bucket)	Length	3.63 m 11 ft. 11 in.
3—Overall Width with 0.32 m (12.6 in.) Track (less bucket)	Width	1.82 m 5 ft. 12 in.
4—Height to Top of ROPS	Height	2.0 m 6 ft. 7 in.
5—Height to Hinge Pin	Height	3.0 m 9 ft. 10 in.
6—Dump Height (with foundry bucket)	Height	2.40 m 7 ft. 11 in.
6—Dump Height (with construction bucket)	Height	2.21 m 7 ft. 3 in.
7—Dump Reach (with foundry bucket)	Reach	0.72 m 2 ft. 4 in.
7—Dump Reach (with construction bucket)	Reach	0.92 m 3 ft. 0 in.
8—Ground Clearance	Height	0.25 m 9.8 in.
9—Angle of Departure	Angle	25°

Continued on next page

OUT4001,000047E -19-16DEC09-1/2

Miscellaneous—Specifications

Item	Measurement	Specification
10—Front Turn Radius (with foundry bucket)	Distance	2.01 m 6 ft. 7 in.
11—Dump Angle (full lift height)	Angle	42°
12—Bucket Rollback (ground level)	Angle	32°
Base Machine with 0.32 m (12.6 in.) Track	Operating Weight	3882 kg 8550 lb

OUT4001,000047E -19-16DEC09-2/2

319D Machine Specifications

Item	Measurement	Specification
John Deere PowerTech E™ 4024HT	Non-Road Emission Standards	Certified EPA Interim Tier 4/Stage IIIB Emissions
	Type	4-Stroke Cycle, Turbocharged, Liquid Cooled
	Bore and Stroke	86 x 105 mm 3.39 x 4.13 in.
	Cylinders	4
	Displacement	2.4 L 149 cu in.
	Peak Net Horsepower (S.N.—203036)	43.3 kw 58.0 hp
	Peak Net Horsepower (S.N. 203037—)	47.1 kw 63.0 hp
	Cooling Fan	Hydraulic Driven, Variable Speed Fan Drive
	Electrical System	12 Volt
	Battery	150 Minutes Reserve Capacity
	Oil Pan Size	0.16 L/kW

PowerTech E is a trademark of Deere & Company

OUT4001,000047F -19-17JUN11-1/1

323D Machine Dimensions

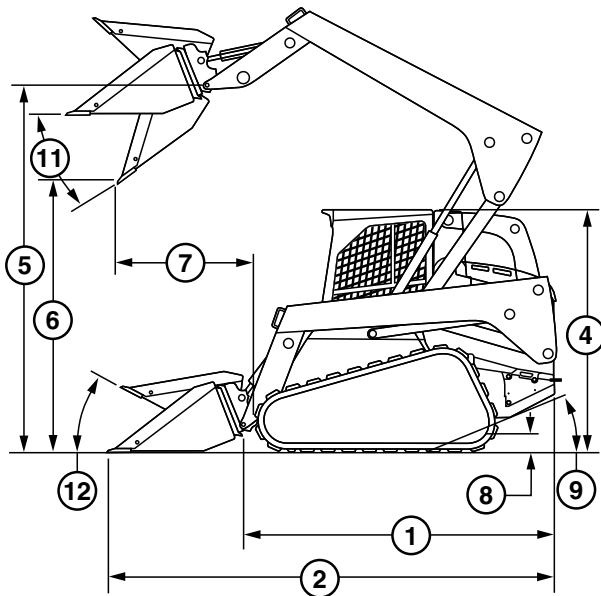

TX1065134—UN—28OCT09

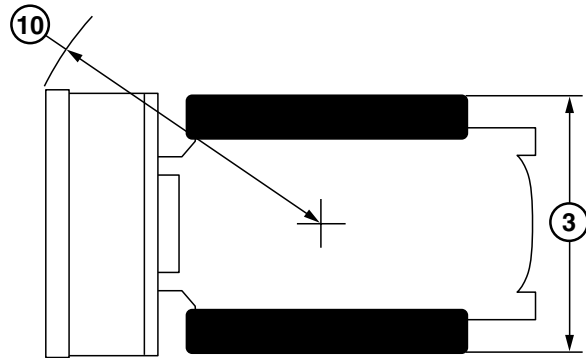

TX1065135—UN—28OCT09

NOTE: Specifications and design subject to change without notice. Wherever applicable, specifications are in accordance with ISO and SAE standards.

Except where otherwise noted, these specifications are based on a machine equipped with standard tracks and bucket.

Item	Measurement	Specification
1—Overall Length (less bucket)	Length	2.74 m 9 ft. 0 in.
2—Overall Length (with foundry bucket)	Length	3.36 m 11 ft. 0 in.
2—Overall Length (with construction bucket)	Length	3.63 m 11 ft. 11 in.
3—Overall Width with 0.32 m (12.6 in.) Track (less bucket)	Width	1.82 m 5 ft. 12 in.
3—Overall Width with 0.40 m (15.7 in.) Track (less bucket)	Width	1.91 m 6 ft. 3 in.
4—Height to Top of ROPS	Height	2.0 m 6 ft. 7 in.
5—Height to Hinge Pin	Height	3.0 m 9 ft. 10 in.
6—Dump Height (with foundry bucket)	Height	2.4 m 7 ft. 11 in.
6—Dump Height (with construction bucket)	Height	2.21 m 7 ft. 3 in.
7—Dump Reach (with foundry bucket)	Reach	0.72 m 2 ft. 4 in.
7—Dump Reach (with construction bucket)	Reach	0.92 m 3 ft. 0 in.
8—Ground Clearance	Height	0.25 m 9.8 in.

Continued on next page

OUT4001,0000480 -19-16DEC09-1/2

Miscellaneous—Specifications

Item	Measurement	Specification
9—Angle of Departure	Angle	25°
10—Front Turn Radius (with foundry bucket)	Distance	2.01 m 6 ft. 7 in.
11—Dump Angle (full lift height)	Angle	42°
12—Bucket Rollback (ground level)	Angle	32°
Base Machine with 0.32 m (12.6 in.) Track	Operating Weight	3882 kg 8550 lb
Base Machine with 0.40 m (15.7 in.) Track	Operating Weight	3984 kg 8775 lb

OUT4001,0000480 -19-16DEC09-2/2

323D Machine Specifications

Item	Measurement	Specification
John Deere PowerTech E™ 4024HT	Non-Road Emission Standards	Certified EPA Interim Tier 4/Stage IIIB Emissions
	Type	4-Stroke Cycle, Turbocharged, Liquid Cooled
	Bore and Stroke	86 x 105 mm 3.39 x 4.13 in.
	Cylinders	4
	Displacement	2.4 L 149 cu in.
	Peak Net Horsepower (S.N.—202965)	47.1 kw 63.0 hp
	Peak Net Horsepower (S.N. 202966—)	51.4 kw 69.0 hp
	Cooling Fan	Hydraulic Driven, Variable Speed Fan Drive
	Electrical System	12 Volt
	Battery	150 Minutes Reserve Capacity
	Oil Pan Size	0.15 L/kW

PowerTech E is a trademark of Deere & Company

OUT4001,0000481 -19-17JUN11-1/1

Miscellaneous—Specifications

319D and 323D Drain and Refill Capacities

Item	Measurement	Specification
Fuel Tank	Capacity	70.0 L 19.0 gal
Cooling System	Capacity	9.3 L 2.5 gal
Engine Oil (including filter)	Capacity	9.0 L 2.4 gal
Hydraulic Tank	Capacity	19.0 L 5.0 gal
Hydrostatic Planetary Gear Case (S.N. —192141) (per side)	Capacity	0.55 L 18.6 oz.
Hydrostatic Planetary Gear Case (S.N. 192142—) (per side)	Capacity	0.79 L 27.0 oz.

ER79617,0000C2D -19-22OCT10-1/1

Rated Operating Capacity

SAE Rated Operating Capacity	
Model	Weight
319D	863 kg (1900 lb)
323D	1044 kg (2300 lb)

OUT4001,000048F -19-28SEP09-1/1

Pallet Fork Lift Chart

Pallet Fork Lift Chart		
Pallet Fork	319D	323D
1070 mm (42 in.)	554 kg (1222 lb)	710 kg (1564 lb)
1220 mm (48 in.)	521 kg (1148 lb)	668 kg (1472 lb)
1220 mm (48 in.) Heavy Duty	509 kg (1121 lb)	656 kg (1445 lb)

Rating based on SAE J1197. Load at 35% tipping capacity and 50% of fork length and fork height giving maximum reach.

OUT4001,00004DC -19-06OCT09-1/1

Index

	Page		Page
A			
Acid burns.....	4-1-2	Battery electrolyte level	
Adjustment		Checking.....	4-1-2
Track tension.....	3-6-2	Beacon (if equipped)	
Air conditioner condenser		Operator's station.....	2-1-20
Inspect and clean.....	3-3-1	Before starting work.....	2-2-1
Air conditioner controls.....	2-1-18	Belt	
Air conditioner switch		Replacement.....	4-1-10
Function.....	2-1-4	Blower speed dial	
Alternator.....	4-1-1	Function.....	2-1-4
Anti-theft security system		Bolt and screw torque values	
Changing operator security code.....	2-1-9	Metric.....	4-1-14
Changing owner security code.....	2-1-9	Unified inch.....	4-1-13
Changing system security code length.....	2-1-10	Boom	
Locking the machine.....	2-1-8	Locking and unlocking.....	2-2-6
Operation.....	2-1-8	Boom and bucket linkage	
Overview.....	2-1-6	Adjusting	
Resetting operator security code.....	2-1-9	Hands only machines.....	4-1-10
Resetting owner security code.....	2-1-9	Boom and bucket speed settings (if	
Selecting the locking method.....	2-1-9	equipped)	
Unlocking the machine.....	2-1-8	Precision.....	2-2-27
Attachment mounting system		Production.....	2-2-27
Electric Quik-Tatch.....	2-2-24	Utility.....	2-2-27
Manual Quik-Tatch.....	2-2-23	Boom lock.....	2-2-6
Attachments		Boom lock lever.....	2-2-6
Adding safely.....	1-3-4	Boom operation	
Installing.....	2-2-23	EH controls	
Operating safely.....	1-3-4	H pattern.....	2-2-14
Removing.....	2-2-23	ISO pattern.....	2-2-14
Auto idle		Manual controls	
Operation.....	2-2-27	Hand and foot machines.....	2-2-9
Auto shutdown.....	2-1-12	Hands only machines.....	2-2-9
Auxiliary fourth function switch		Boom release	
Function.....	2-1-4	EH machine.....	2-2-7
Auxiliary hydraulic override switch		Engine stalled.....	2-2-7
Function.....	2-1-4	Location.....	2-2-7
Auxiliary hydraulics		Manual machine.....	2-2-7
EH controls.....	2-2-18	Break-in engine oil.....	3-1-6
Manual controls.....	2-2-18	Break-in period.....	2-2-3
Operation.....	2-2-18	Breather element	
B			
Batteries		Replace.....	3-9-5
Boost starting.....	4-1-5	Bucket operation	
Using battery charger.....	4-1-5	EH controls	
Battery		H pattern.....	2-2-16
Acid burns.....	4-1-2	ISO pattern.....	2-2-16
Electrolyte level check.....	4-1-2	Manual controls	
Explosion.....	4-1-2	Hand and foot machines.....	2-2-11
Handling, checking, and servicing.....	4-1-4	Hands only machines.....	2-2-11
Remove and install.....	4-1-6	Bulbs	
Replacement.....	4-1-6	Remove and install.....	4-1-8
Specification.....	4-1-6	C	
Terminals.....	4-1-2	Cab door.....	2-1-13
B			
Batteries		Safety precautions.....	1-4-3
Boost starting.....	4-1-5	Cab door switch	
Using battery charger.....	4-1-5	Indicator.....	2-1-11
Battery			
Acid burns.....	4-1-2		
Electrolyte level check.....	4-1-2		
Explosion.....	4-1-2		
Handling, checking, and servicing.....	4-1-4		
Remove and install.....	4-1-6		
Replacement.....	4-1-6		
Specification.....	4-1-6		
Terminals.....	4-1-2		

Continued on next page

Index

	Page		Page
Cab fresh air filter		John Deere Cool-Gard II Coolant Extender	3-1-10
Check and clean	3-3-2	Sample	3-9-7
Cab temperature control dial		Supplemental additives	3-1-10
Function	2-1-4	Test	3-3-3, 3-10-1
Capacities		Testing	3-1-13
Drain and refill	4-6-5	Warm temperature climates	3-1-6, 3-1-11
Charge air cooler		Cooling	
Inspect and clean	3-3-1	System drain	3-11-1
Cold weather starting	2-2-4	Cooling system	
Control levers		Filling	3-11-2
Buttons	2-1-1	Flushing	3-11-2
Control panel		Counterweights	
Air conditioner switch	2-1-3	Install	4-1-9
Auxiliary fourth function switch	2-1-3	Creep mode	
Auxiliary hydraulic override switch	2-1-3	Operation	2-2-26
Blower speed dial	2-1-3	Creep mode switch	
Cab temperature control dial	2-1-3	Function	2-1-4
Creep mode switch	2-1-3	Cylinder	4-1-1
Dual flasher switch	2-1-3		
Engine speed control dial	2-1-3	D	
High flow switch	2-1-3	Daily machine check	2-2-1
Key switch	2-1-3	Diagnostic trouble codes	
Park brake switch	2-1-3	Engagement and monitor unit	2-1-11
Pattern select switch	2-1-3	Diagnostic trouble codes (DTCs)	
Quik-tatch switch	2-1-3	Reading	2-1-11
Reversing fan switch	2-1-3	Diesel fuel	3-1-1, 3-1-3
Self leveling switch	2-1-3	Sample	3-9-7
Water-in-fuel (WIF) indicator	2-1-3	Diesel fuel, testing	
Work lights switch	2-1-3	Testing Diesel Fuel	3-1-4
Control panel functions	2-1-4	Dome light	2-1-20
Controls		Drain Intervals for Diesel Engine Coolant	
Boom and bucket	2-1-1	Diesel Engine Coolant, Drain Intervals	3-1-9
EH options	2-1-1	Dual flasher switch	
Auxiliary flow set switch	2-1-1	Function	2-1-4
Auxiliary proportional switch	2-1-1	E	
Auxiliary second function A switch	2-1-1	EH controls	
Auxiliary second function B switch	2-1-1	H pattern	
Auxiliary third function A switch	2-1-1	Boom operation	2-2-14
Auxiliary third function B switch	2-1-1	Bucket operation	2-2-16
Float switch	2-1-1	ISO pattern	
Horn (if equipped)	2-1-1	Boom operation	2-2-14
Two speed switch (if equipped)	2-1-1	Bucket operation	2-2-16
Manual options	2-1-1	Electrical	
Auxiliary flow set switch	2-1-1	Troubleshooting	4-3-2
Auxiliary proportional switch	2-1-1	EMU	
Auxiliary second function A switch (if equipped) ..	2-1-1	Anti-theft security system	2-1-8
Auxiliary second function B switch (if equipped) ..	2-1-1	Display messages	2-1-7
Auxiliary third function A switch (if equipped)	2-1-1	Operation	2-1-6
Auxiliary third function B switch (if equipped)	2-1-1	Engagement and monitor unit (EMU)	
Horn (if equipped)	2-1-1	Anti-theft security system	2-1-8
Two speed switch (if equipped)	2-1-1	Display messages	2-1-7
Coolant		Operation	2-1-6
Add coolant extender	3-3-3, 3-10-1	Engine	
Additional information	3-1-12	Break-in period	2-2-3
Check	3-3-3, 3-10-1		
Diesel engine			
Light duty	3-1-9		
Heater	2-2-4		

Continued on next page

Index

	Page		Page
Cold start.....	2-2-4	Footwell	
Oil change.....	3-7-1, 3-9-1	Removal.....	3-2-6
Oil filter change.....	3-7-1, 3-9-1	Fuel	
Oil level check.....	3-4-1	Diesel.....	3-1-1, 3-1-3
Starting.....	2-2-3	Handling and storing.....	3-1-2
Stopping.....	2-2-5	Lubricity.....	3-1-1
Troubleshooting.....	4-3-1	Fuel filter	
Engine air filter restriction		In-line.....	3-9-3
Indicator.....	2-1-11	Fuel filter and water separator	
Engine block heater.....	2-2-4	Replace.....	3-9-2
Engine coolant temperature gauge.....	2-1-11	Fuel gauge.....	2-1-11
Engine cover		Fuel tank	
Opening and closing.....	3-2-4	Capacity.....	3-2-1
Engine low oil pressure		Fuel tank sump	
Indicator.....	2-1-11	Drain.....	3-9-6
Engine oil		Fuel tank vent tube	
Break-In.....	3-1-6	Inspect and clean.....	3-3-2
Sample.....	3-8-1	Functions	
Engine oil and filter service intervals.....	3-1-8	Control panel.....	2-1-4
Engine serial number.....	4-5-1	Fuses	
Engine side panels		Designations.....	4-1-11
Remove and install.....	3-2-4	Glow plug	
Engine specifications		Designation.....	4-1-12
319D.....	4-6-2	Location.....	4-1-12
323D.....	4-6-4	Location.....	4-1-11
Engine speed control			
Dial.....	2-2-5	G	
Pedal.....	2-2-5	Gauge and indicator light	
Engine speed control dial.....	2-1-1	Functions.....	2-1-12
Function.....	2-1-4	Gauge functions.....	2-1-12
Engine speed control pedal.....	2-1-1	Gauges.....	2-1-11
Engine		Gear case oil.....	3-1-14
Oil specification		Glow plug	
IT4 and Stage III B.....	3-1-7	Indicator.....	2-1-11
Entering skid steer.....	2-2-2	Grease.....	3-1-14
Exiting skid steer.....	2-2-2		
F		H	
Filling cooling system.....	3-11-2	Halogen bulbs	
Filter		Remove and install.....	4-1-8
Cab fresh air		Handhold use.....	1-3-1
Clean.....	3-3-2	Hardware torque values	
Engine oil.....	3-7-1, 3-9-1	Metric.....	4-1-14
Hydraulic oil.....	3-9-5	Unified inch.....	4-1-13
Primary engine air.....	3-9-4	Heater	
Recirculation air		Coolant.....	2-2-4
Clean.....	3-3-2	Heater controls.....	2-1-18
Secondary engine air.....	3-10-2	High flow hydraulics (if equipped).....	2-2-25
Fire extinguisher		High flow switch.....	2-2-25
Location.....	2-1-17	Function.....	2-1-4
Fire prevention.....	1-2-4	High-pressure oils	
Fluid analysis test kit.....	3-2-6	Avoid.....	1-2-3
Flushing cooling system.....	3-11-2	Horn button.....	2-1-20
Foot pedals		Hydraulic	
Adjusting angle position.....	4-1-11	Oil change.....	3-10-4
Hand and foot machine only.....	2-1-1	Oil filter replace.....	3-9-5

Continued on next page

Index

	Page		Page
Oil level check.....	3-4-1		
Oil specification.....	3-1-13		
Oil tank breather element replace.....	3-9-5		
System, pressure release	2-2-21		
Troubleshooting	4-3-3		
Hydraulic oil cooler			
Inspect and clean.....	3-3-1		
Hydraulic oil filter restriction			
Indicator	2-1-11		
Hydraulic oil temperature			
Indicator	2-1-11		
Hydraulics			
EH controls	2-2-21		
Manual controls.....	2-2-21		
Hydraulics Off			
Indicator	2-1-11		
Hydrostatic			
Oil specification.....	3-1-13		
Planetary oil	3-5-1, 3-7-2, 3-9-7, 3-10-3		
Hydrostatic planetary gear case			
(S.N. —192141).....	3-7-2, 3-9-7		
(S.N. 192142—).....	3-5-1, 3-10-3		
I			
In-line fuel filter			
Replace.....	3-9-3		
Indicator			
Cab door switch	2-1-11		
Engine air filter restriction	2-1-11		
Engine low oil pressure.....	2-1-11		
Glow plug	2-1-11		
Hydraulic oil filter restriction.....	2-1-11		
Hydraulic oil temperature.....	2-1-11		
Hydraulics OFF	2-1-11		
Low alternator or battery voltage	2-1-11		
Seat belt switch.....	2-1-11		
Seat switch.....	2-1-11		
STOP	2-1-11		
Two speed.....	2-1-11		
Indicator light functions.....	2-1-12		
Indicator lights	2-1-11		
Interlocking seat bar			
Function	2-1-13		
J			
Joysticks			
Buttons.....	2-1-1		
K			
Key switch			
Function	2-1-4		
Key switch off, engine off checks	4-2-1		
Key switch on, engine off checks	4-2-1		
Key switch on, engine on checks	4-2-3		
L			
Lift chart			
Pallet fork.....	4-6-5		
Low alternator or battery voltage			
Indicator	2-1-11		
Lubricants, Safety			
Safety, Lubricants	3-1-6		
Lubricate			
Boom linkage	3-6-1		
Cylinder pivot points.....	3-6-1		
QUIK-TATCH linkage.....	3-6-1		
Steering linkage	3-9-6		
Lubricity of diesel fuel.....	3-1-1		
M			
Machine			
Blocking location.....	3-2-2		
Lifting area	3-2-2		
Raising and blocking.....	3-2-2		
Service	3-2-1		
Trailer loading	2-2-28		
Machine dimensions			
319D	4-6-1		
323D	4-6-3		
Machine modifications			
Avoid.....	1-2-2		
Machine movement			
Unintended.....	1-3-1		
Machine specifications			
319D	4-6-2		
323D	4-6-4		
Machine,inspect.....	1-2-2		
Maintenance			
Required parts	3-2-8		
Schedule and record.....	3-2-7		
Manual controls			
Hand and foot machines			
Boom operation.....	2-2-9		
Bucket operation	2-2-11		
Hands only machines			
Boom operation.....	2-2-9		
Bucket operation	2-2-11		
MENU button	2-1-11		
Metric bolt and screw torque values	4-1-14		
Motor	4-1-1		
Moving parts			
Safety.....	1-2-2		
Servicing.....	1-2-2		
N			
Normal break-in			
Rubber track	2-3-5		

Continued on next page

	Page		Page
O			
Oil		Key switch on, engine on.....	4-2-3
Engine change.....	3-7-1, 3-9-1	Lights circuit.....	4-2-2
Engine sample.....	3-8-1	Mistracking.....	4-2-5
Hydraulic.....	3-1-13	Monitor and gauge circuit	
Hydraulic change.....	3-10-4	Key off.....	4-2-1
Hydraulic sample.....	3-9-7	Key on.....	4-2-2
Hydrostatic.....	3-1-13	Reverse alarm.....	4-2-5
Hydrostatic planetary.....	3-5-1, 3-7-2, 3-9-7, 3-10-3	Self leveling valve.....	4-2-9
Hydrostatic planetary gear case.....	3-1-14	Steering mistracking.....	4-2-5
Hydrostatic planetary gear case sample.....	3-9-7	Tail lights.....	4-2-2
Level check hydraulic.....	3-4-1	Windshield wiper circuit.....	4-2-3
Level check, engine.....	3-4-1	Windshield washer circuit.....	4-2-3
Oil cooler		Work lights.....	4-2-2
Inspect and clean.....	3-3-1	Operator convenience.....	1-1-1
Oil, engine		Operator's station	
IT4 and Stage III B.....	3-1-7	Beacon light.....	2-1-20
Operating capacity weights.....	4-6-5	Raising and lowering.....	3-2-3
Operation		P	
Auto idle.....	2-2-27	Pallet fork lift chart.....	4-6-5
Creep mode (if equipped).....	2-2-26	Park brake	
Operation qualification.....	1-2-1	Indicator.....	2-1-11
Operational check		Park brake switch	
Air conditioning and heating system.....	4-2-9	Function.....	2-1-4
Auxiliary hydraulic override.....	4-2-8	Pattern select switch.....	2-1-1
Back-up alarm.....	4-2-5	Function.....	2-1-4
Boom down		Pedals	
Cylinder drift.....	4-2-5	Hand and foot machine only.....	2-1-1
Boom down drift.....	4-2-5	Pilot control shutoff lever.....	1-3-1
Boom enable.....	4-2-4	Pins, metal	
Boom up		Drive safely.....	1-4-2
Cylinder drift.....	4-2-6	Power outlet.....	2-1-18
Boom up drift.....	4-2-6	Pre-start inspection.....	2-2-1
Bucket curl		Pressure release	
Cylinder drift.....	4-2-8	Hydraulic system.....	2-2-21
Bucket curl drift.....	4-2-8	Primary engine air filter	
Bucket dump		Replace.....	3-9-4
Cylinder drift.....	4-2-7	Product identification number.....	4-5-1
Bucket dump drift.....	4-2-7	Pump	
Bucket enable.....	4-2-4	Service.....	4-1-1
Cycle times		Q	
319D.....	4-2-9	Quik-Tatch	
323D.....	4-2-10	Electric.....	2-2-24
Diagnostic trouble codes (DTCs).....	4-2-1	Manual.....	2-2-23
Electric Quik-Tatch.....	4-2-4	Switch function.....	2-1-4
Engine idle.....	4-2-3	R	
Engine speed.....	4-2-4	Radiator	
Engine start.....	4-2-3	Coolant level check.....	3-4-2
Heating and air conditioning system.....	4-2-9	Inspect and clean.....	3-3-1
Horn circuit.....	4-2-2	Rated operating capacity.....	4-6-5
Hydraulic control enable.....	4-2-4	Rear window.....	2-1-17
Indicators and gauges			
Key off.....	4-2-1		
Key on.....	4-2-2		
Key switch off, engine off checks.....	4-2-1		
Key switch on, engine off checks.....	4-2-1		

Continued on next page

Index

	Page		Page
Recirculation air filter		Self leveling (if equipped)	2-2-25
Check and clean	3-3-2	Self leveling switch	2-2-25
Recognize		Function	2-1-4
Safety, information	1-2-1	Serial number	
Regulator	4-1-1	Engine	4-5-1
Reversing fan switch		Service	
Function	2-1-4	Machine	3-2-1
Rubber track		Service ADVISOR connector.....	2-1-18
Normal break-in	2-3-5	Side windows	
Structure	2-3-2	Opening and closing	2-1-16
Types of damages.....	2-3-6	Removing and installing.....	2-1-16
Crack on tread lug side rubber-fatigue	2-3-6	Skid steer	
Cut on tread lug side rubber.....	2-3-6	Entering.....	2-2-2
Cut steel cord	2-3-9	Exiting	2-2-2
Cuts on the edges of the track roller side rubber..	2-3-7	Slopes	
Deterioration of the track roller side		Operation on	1-3-3
rubber surface	2-3-8	Specification	
Separation of metal inserts-external		Hardware torque	4-1-13
forces and corrosion	2-3-8	Sprocket teeth	
Tread lug abrasion	2-3-7	Wear	2-3-4
Usage.....	2-3-3	Starting	
		Cold weather	2-2-4
		Engine.....	2-2-3
		Steering	
		EH joysticks	
		H pattern.....	2-2-12
		ISO pattern	2-2-12
		Manual control levers.....	2-2-8
		Steering linkage	
		Lubricate	3-9-6
		Steps use.....	1-3-1
		STOP	
		Indicator	2-1-11
		Stopping	
		Engine.....	2-2-5
		Storage	
		Machine	4-4-1
		Monthly	4-4-2
		Storing fuel	3-1-2
		Structure	
		Rubber track	2-3-2
		T	
		Tie down locations	2-2-28
		Top window.....	2-1-17
		Torque charts	
		Metric	4-1-14
		Unified inch	4-1-13
		Track	
		Damage	2-3-6
		Crack on tread lug side rubber-fatigue	2-3-6
		Cut on tread lug side rubber.....	2-3-6
		Cut steel cord	2-3-9
		Cuts on the edges of the track roller side rubber..	2-3-7
		Deterioration of the track roller side	
		rubber surface	2-3-8

S

T

Continued on next page

Index

	Page		Page
Separation of metal inserts-external forces and corrosion	2-3-8	EPA	-3
Tread lug abrasion	2-3-7	Water separator	
Track tension		Fuel filter	3-9-2
Adjustment	3-6-2	Water separator fuel filter	
Track wear	2-3-5	Drain	3-4-2
Transporting machine	2-2-28	"Water-in-fuel indicator"	
Troubleshooting procedure	4-3-1	"Function"	2-1-4
Two speed		Wear	
Indicator	2-1-11	Sprocket teeth	2-3-4
U		Weights	
Undercarriage		Operating capacity	4-6-5
Components	2-3-1	Welding	4-1-7
Unified inch bolt and screw torque values	4-1-13	Welding repairs	
Usage		Make safely	1-4-2
Rubber track	2-3-3	Window	
V		Rear	2-1-17
Valve		Sides	2-1-16
Control	4-1-1	Top	2-1-17
W		Wiper assembly	2-1-13
Warranty		Work lights	
Non-road emissions control warranty statement--compression ignition		Remove and install halogen bulbs	4-1-8
CARB	-5	Work lights switch	
		Function	2-1-4

